

Plastic Infrared Emitting Diode

OP265, OP266 Series

(A, B, C, D, W)



Features:

- T-1 (3 mm) package style
- Choice of narrow or wide irradiance pattern
- Choice of dome or flat lens
- Mechanically and spectrally matched to other OPTEK devices
- Higher power output than GaAs at equivalent drive currents
- 890 nm diodes

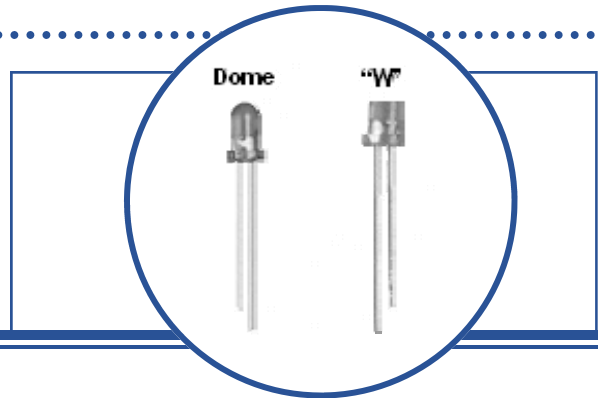

Description:

Each device in the **OP265** and **OP266** series is a high intensity gallium arsenide infrared emitting diode (GaAs) that is molded in an IR transmissive clear epoxy package with either a dome or flat lens. Devices feature narrow and wide irradiance patterns and a variety of electrical characteristics. The small T-1 package style makes these devices ideal for space-limited applications.

OP265 devices conform to the OP505 and OP535 series devices. OP266 devices conform to OP506 series devices.

Please refer to Application Bulletins 208 and 210 for additional design information and reliability (degradation) data.

Applications:

- Space-limited applications
- Applications requiring coupling efficiency
- Battery-operated or voltage-limited applications

Ordering Information					
Part Number	LED Peak Wavelength	Output Power (mW/cm ²) Min / Max	I _F (mA) Typ / Max	Total Beam Angle	Lead Length
OP265A	890 nm	2.70 / NA	20 / 50	18°	See page 2
OP265B		1.65 / 4.70			
OP265C		0.54 / 3.30			
OP265D		0.54 / NA			
OP265W		1.00 / NA		90°	
OP266A		2.70 / NA			
OP266B		1.65 / 4.70		18°	
OP266C		0.54 / 3.30			
OP266D		0.54 / NA			
OP266W		1.00 / NA			



RoHS

OPTEK reserves the right to make changes at any time in order to improve design and to supply the best product possible.

Plastic Infrared Emitting Diode

OP265, OP266 Series

(A, B, C, D, W)



OP265 (A, B, C, D)

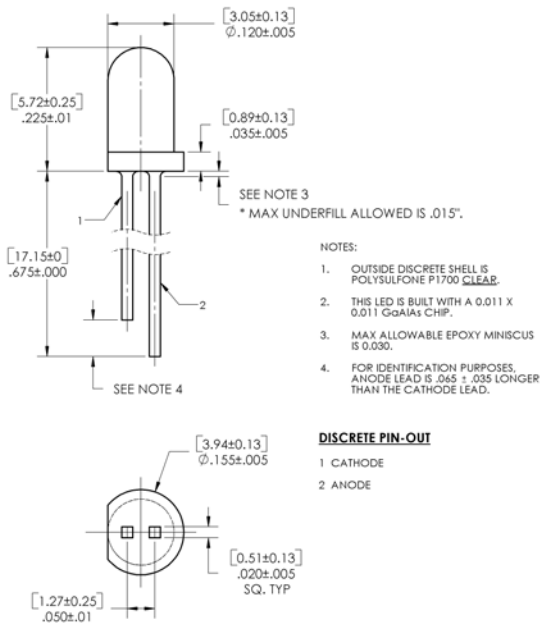

OP265W

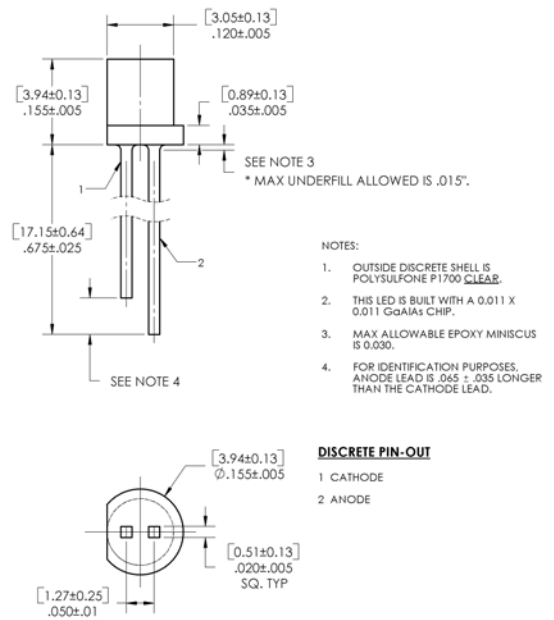

DIMENSIONS ARE IN: [MILLIMETERS] INCHES

OP266 (A, B, C, D)

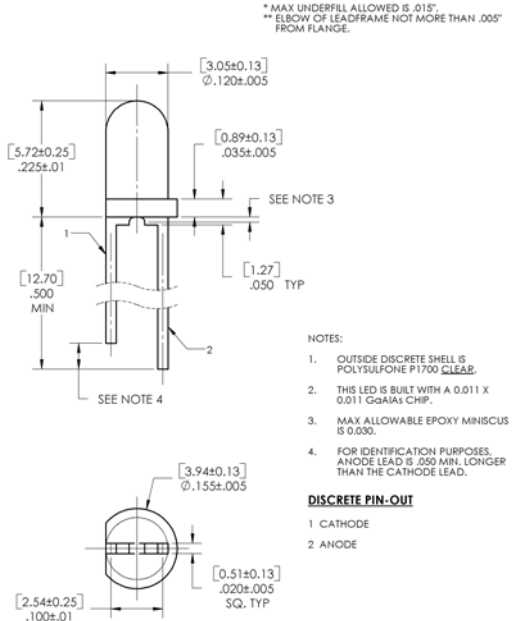

OP266W

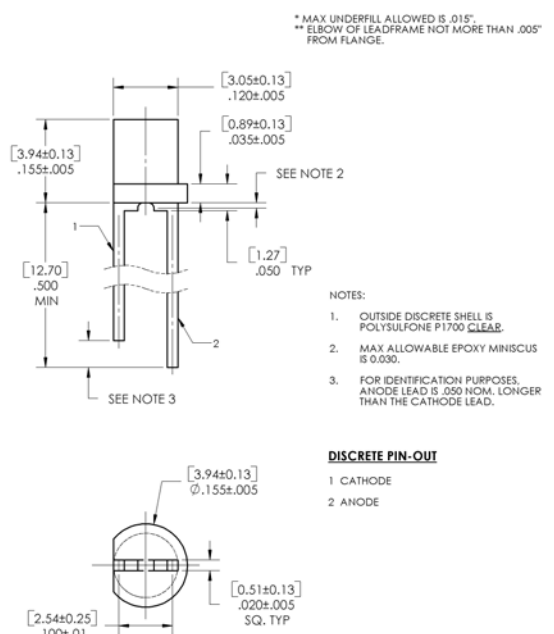

Pin #	LED
1	Cathode
2	Anode

CONTAINS POLYSULFONE

To avoid stress cracking, we suggest using ND Industries' **Vibra-Tite** for thread-locking. **Vibra-Tite** evaporates fast without causing structural failure in OPTEK'S molded plastics.

OPTEK reserves the right to make changes at any time in order to improve design and to supply the best product possible.

Plastic Infrared Emitting Diode

OP265, OP266 Series

(A, B, C, D, W)



Absolute Maximum Ratings ($T_A = 25^\circ\text{C}$ unless otherwise noted)

Storage and Operating Temperature Range	-40° C to +100° C
Reverse Voltage	2.0 V
Continuous Forward Current	50 mA
Peak Forward Current (1 μs pulse width, 300 pps)	3.0 A
Lead Soldering Temperature [1/16 inch (1.6 mm) from case for 5 seconds with soldering iron]	260° C
Power Dissipation	100 mW ⁽¹⁾

Electrical Characteristics ($T_A = 25^\circ\text{C}$ unless otherwise noted)

SYMBOL	PARAMETER	MIN	TYP	MAX	UNITS	TEST CONDITIONS
--------	-----------	-----	-----	-----	-------	-----------------

Input Diode

$E_{E(APT)}$	Apertured Radiant Incidence OP265A, OP266A OP265B, OP266B OP265C, OP266C OP265D, OP266D	2.70 1.65 0.54 0.54	- - - -	- 4.70 3.30 -	mW/cm ²	$I_F = 20\text{ mA}^{(2)}$
P_O	Radiant Power Output OP265, OP266 (A, B, C, D) OP265W, OP266W	- 1.00	- -	- -	mW	$I_F = 20\text{ mA}$
V_F	Forward Voltage	-	-	1.80	V	$I_F = 20\text{ mA}$
I_R	Reverse Current	-	-	100	μA	$V_R = 2\text{ V}$
λ_P	Wavelength at Peak Emission	-	890	-	nm	$I_F = 10\text{ mA}$
B	Spectral Bandwidth between Half Power Points	-	80	-	nm	$I_F = 10\text{ mA}$
$\Delta\lambda_P/\Delta T$	Spectral Shift with Temperature OP265, OP266 (A, B, C, D) OP265W, OP266W	- -	± 0.30 ± 0.18	- -	nm/°C	$I_F = \text{Constant}$
θ_{HP}	Emission Angle at Half Power Points OP265, OP266 (A, B, C, D) OP265W, OP266W	- -	18 90	- -	Degree	$I_F = 20\text{ mA}$
t_r	Output Rise Time	-	500	-	ns	$I_{F(PK)} = 100\text{ mA}$, PW=10 μs , D.C.=10.0%
t_f	Output Fall Time	-	250	-	ns	

Notes:

- Derate linearly 1.33 mW/°C above 25°C
- $E_{E(APT)}$ is a measurement of the average apertured radiant incidence upon a sensing area 0.081" (2.06 mm) in diameter, perpendicular to and centered on the mechanical axis of the lens, and 0.590" (14.99 mm) from the measurement surface. $E_{E(APT)}$ is not necessarily uniform within the measured areas.

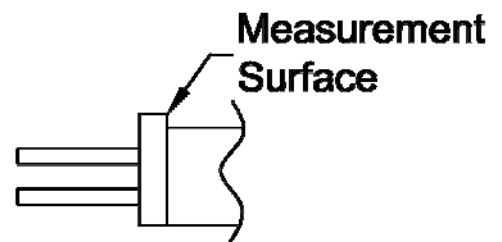

OPTEK reserves the right to make changes at any time in order to improve design and to supply the best product possible.

Plastic Infrared Emitting Diode

OP265, OP266 Series

(A, B, C, D, W)



OP265, OP266 (A, B, C, D, W)

Forward Voltage vs Forward Current vs Temperature

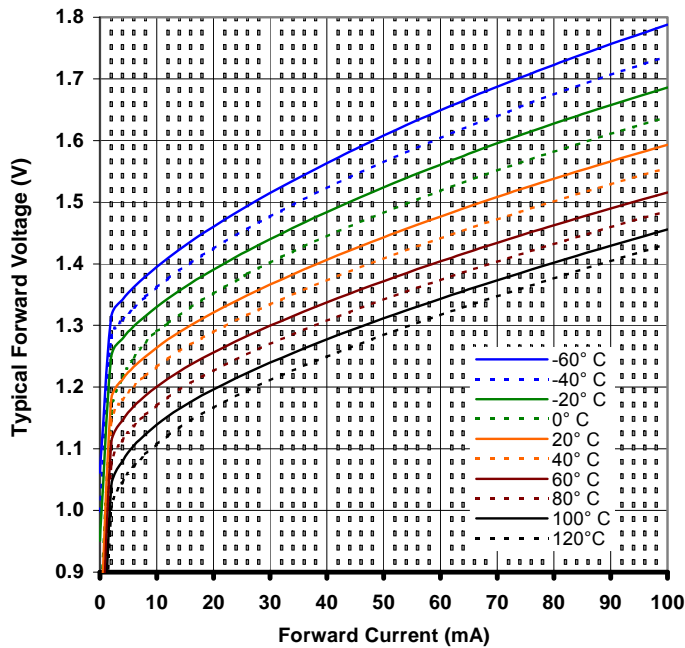

Optical Power vs I_F vs Temperature

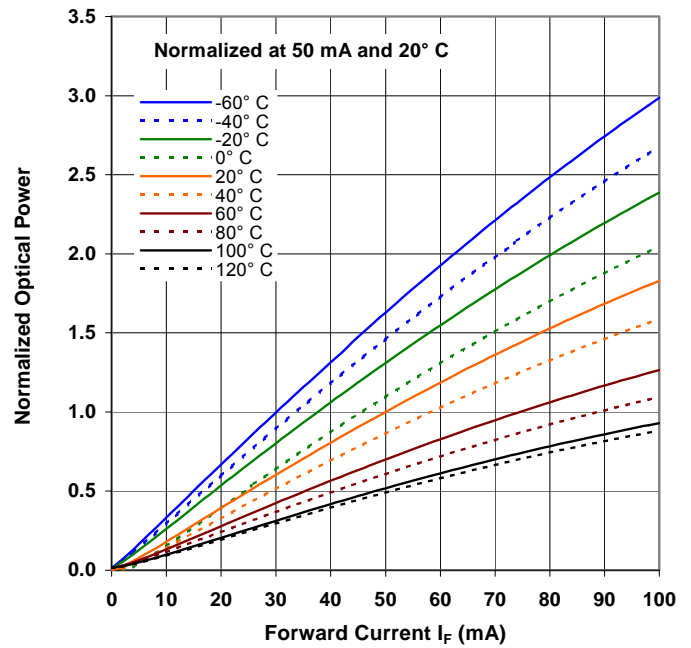

Distance vs Output Power vs Forward Current

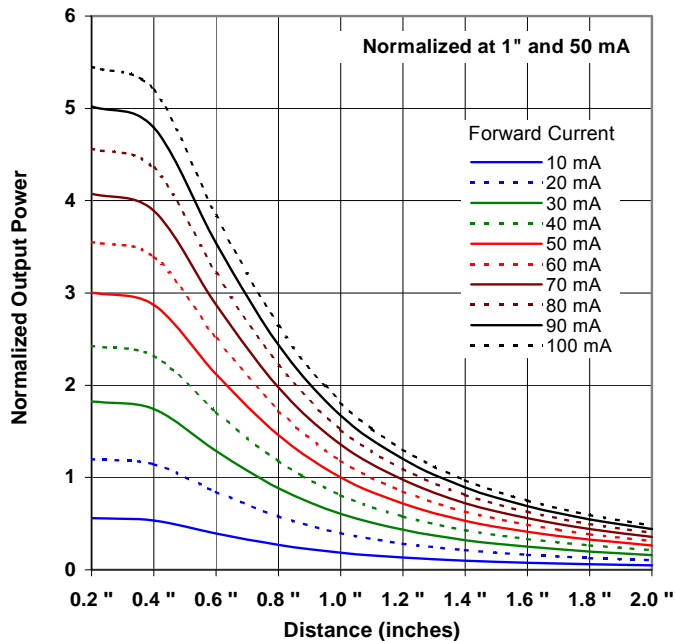

Relative Radiant Intensity vs. Angular Displacement

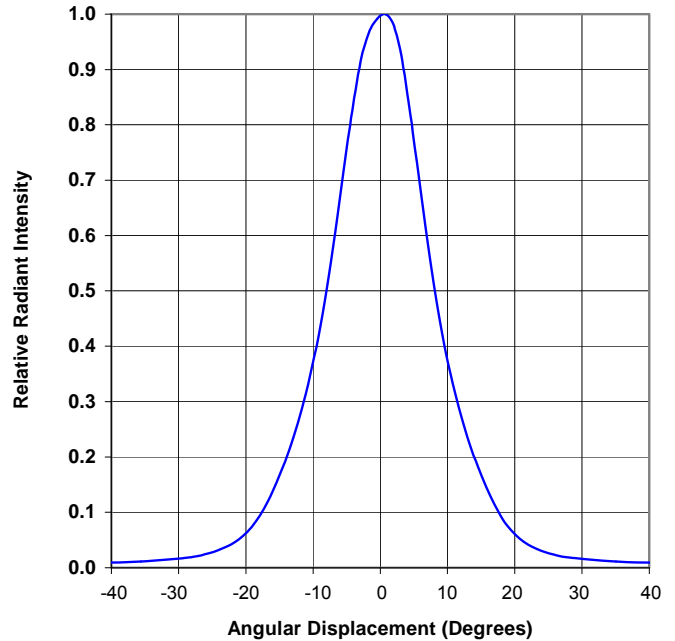

OPTEK reserves the right to make changes at any time in order to improve design and to supply the best product possible.