

## MPMS19-C0



- Used to secure wire cable or tubing to masonry surfaces. Installed quickly into pre-drilled holes. Design holds bundle securely.

■ Part Number	MPMS19-C0
■ RoHS Compliancy Status	Compliant
■ Part Description	Masonry Push Barb Cable Tie Mount
■ Product Type	Cable Tie Mounts - Push Mount
■ Material	Impact Modified Weather Resistant Nylon 6.6
■ Color	Black
■ Height (In.)	.25
■ Height (mm)	6.4
■ Length (mm)	24.6
■ Width (In.)	.37
■ Width (mm)	9.4
■ CE Compliant	CT-ACC4 / 10.96
■ Environment	Outdoors
■ Grip Length (In.)	.97
■ Grip Length (mm)	24.6
■ Hole Diameter (In.)	.19
■ Hole Diameter (mm)	5.0
■ Max. Bundle Diameter (mm)	4.8
■ Mounting Method	Tree Barb
■ Pricing Description	Masonry Push Mount, Standard, .19" (4.8mm) Hole, BL
■ Thickness (In.)	.40
■ Thickness (mm)	10.2
■ Used With Cable Ties	M, I, S
■ Min. Order UOM	PC
■ Min. Order Qty.	100
■ BOM Qty. (# of Pkgs.)	

THIS COPY IS PROVIDED ON A RESTRICTED BASIS AND IS NOT TO BE USED IN ANY WAY DETRIMENTAL TO THE INTERESTS OF PANDUIT CORP.

PANDUIT PART NO. *	USE WITH CABLE TIE	HOLE SIZE inch / (mm)	WEIGHT lbs / 100 (g) / pcs
MPMS19-	M, I, S, SG100M, SG1501, SG200S, SG250S, SG300S,	0.187 dia x 1.25 deep (5.0 dia x 31.8 deep)	0.18 (83)
SGMPMS19-	SG370S		
MPMH38-	M, I, S, LH, H SG100M, SG1501, SG200S, SG250S, SG300S, SG370S,	0.375 dia x 1.50 deep (10.0 dia x 38.1 deep)	0.464 (210.6)
SGMPMH38-	SG350LH, SG450H		

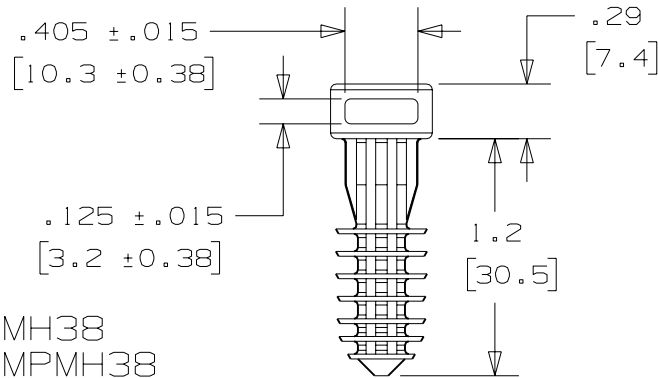
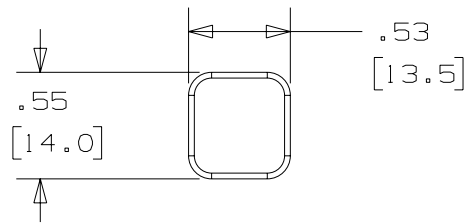

MPMH38  
SGMPMH38

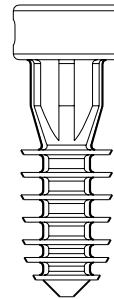

NOTES:

- SEE CURRENT PRICE SHEET FOR PART NUMBER SUFFIX DESIGNATION FOR PACKAGE SIZE.
- MATERIAL: WEATHER RESISTANT NYLON 6/6  
COLOR: BLACK

MPMS19  
SGMPMS19

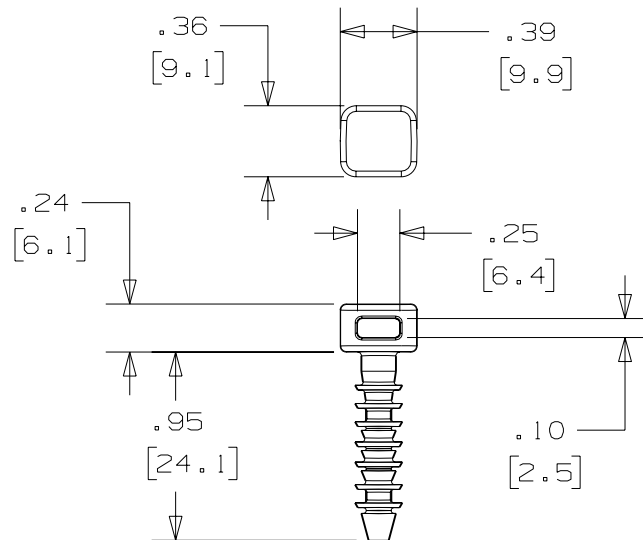

DIMENSIONS IN BRACKETS ARE METRIC [ mm ]			
CAD FILENAME/LAYERS G002391G_PB_MPM_01			
 TINLEY PARK, ILLINOIS			
MASONRY PUSH MOUNT (MPMS19-, SGMPMS19-, MPMH38-, SGMPMH38-)			
UNLESS OTHERWISE SPECIFIED, DIMENSIONAL TOLERANCES ARE: (.X) ±0.05 (1.3) (.XXX) ±0.010 (0.25) (.XX) ±0.02 (0.5) ANGLES ± 5°		UNLESS OTHERWISE SPECIFIED, ALL DIMENSIONS ARE GIVEN IN INCHES, THIRD ANGLE PROJECTION.	
DRAWN BY JAD	MAT'L:	SCALE NONE	
DATE 9/24/03	SEE NOTE 2	DRAWING NO.	DWG
CHK'D		G002391G	A SIZE

1	6-20-06	TMSA		ADDED PART NUMBER SGMPMH38 & SGMPMS19 REVISED DIMENSIONS FOR SGMPMS19, SGMPMH38	GB02391G	1				
REV	DATE	BY	CHK	DESCRIPTION	ECN	R	CUST	SUP		