

5650461-5 Product Details

[Share](#) [Print](#) [Email](#)

Detailed product features are not currently available online.

Product features can often be found by referring to the available documents. [Contact us](#) for information about this product.

No Image Available

ASSY,RECEPTACLE,EUROCARD,TYPE

Always EU RoHS/ELV Compliant
(Statement of Compliance)

Quick Links

- ▶ [Pricing & Availability](#)
- ▶ [Search for Tooling](#)
- ▶ [Contact Us About This Product](#)

5650461-5

TE Internal Number: 5650461-5

[Active](#)

[View 3D PDF](#)

[Add to My Part List](#)

[Buy Product](#)

Documentation & Additional Information	
<p>Product Drawings:</p> <ul style="list-style-type: none"> • ASSEMBLY, RECEPTACLE, EUROCARD, TYPE R, LEAD-FREE, 9... (PDF, English) <p>Catalog Pages/Data Sheets:</p> <ul style="list-style-type: none"> • None Available <p>Product Specifications:</p> <ul style="list-style-type: none"> • None Available <p>Application Specifications:</p> <ul style="list-style-type: none"> • Eurocard Connectors Types B,C,M,Q,R, & Enhanced Typ... (PDF, English) <p>Instruction Sheets:</p> <ul style="list-style-type: none"> • None Available <p>CAD Files: (CAD Format & Compression Information)</p> <ul style="list-style-type: none"> • 2D Drawing (DXF, Version 0) • 3D Model (IGES, Version 0) • 3D Model (STEP, Version 0) <p style="text-align: right;">List all Documents</p>	<p>Related Products:</p> <ul style="list-style-type: none"> • Tooling

Corporate Information

- [About TE](#)
- [Investors](#)
- [News Room](#)
- [Supplier Portal](#)
- [Careers](#)
- [Terms & Conditions](#)
- [Privacy Policy](#)

Quick Links

- [Distributor Inventory](#)
- [Product Cross Reference](#)
- [Documents & Drawings](#)
- [Product Compliance Support Center](#)
- [Site Map](#)

Customer Support

- [Email or Chat With Us](#)
- [Find a Phone Number](#)
- [Knowledge Base](#)
- [Manage Your Account](#)

Keep Me Informed



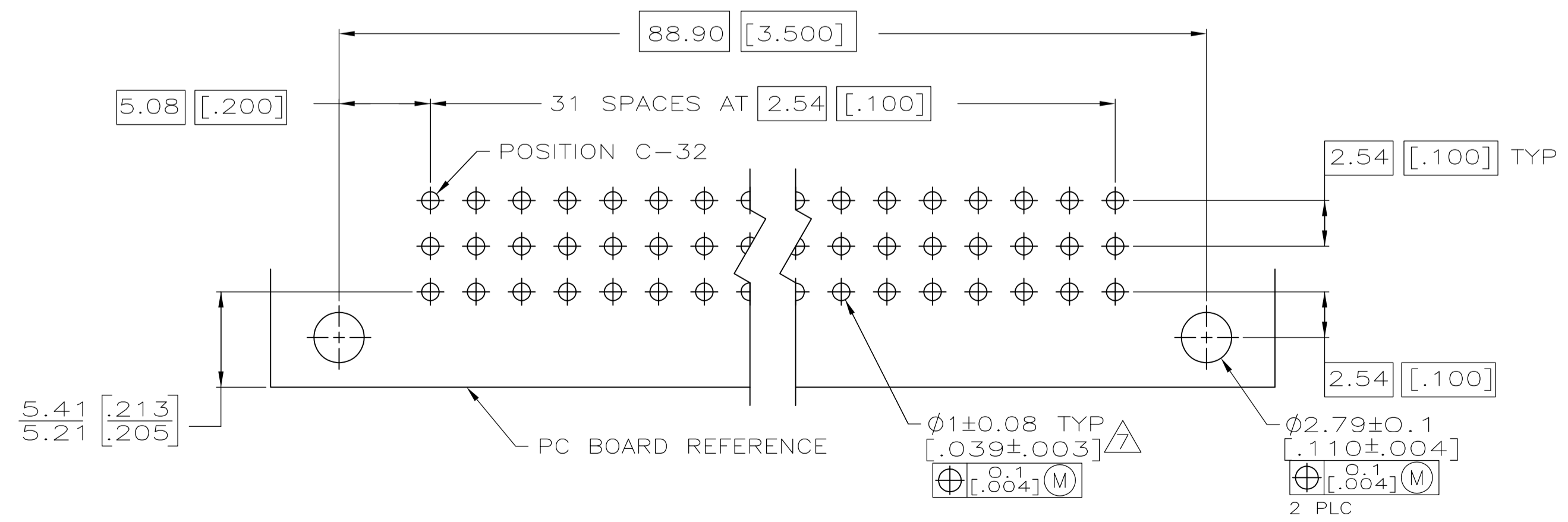
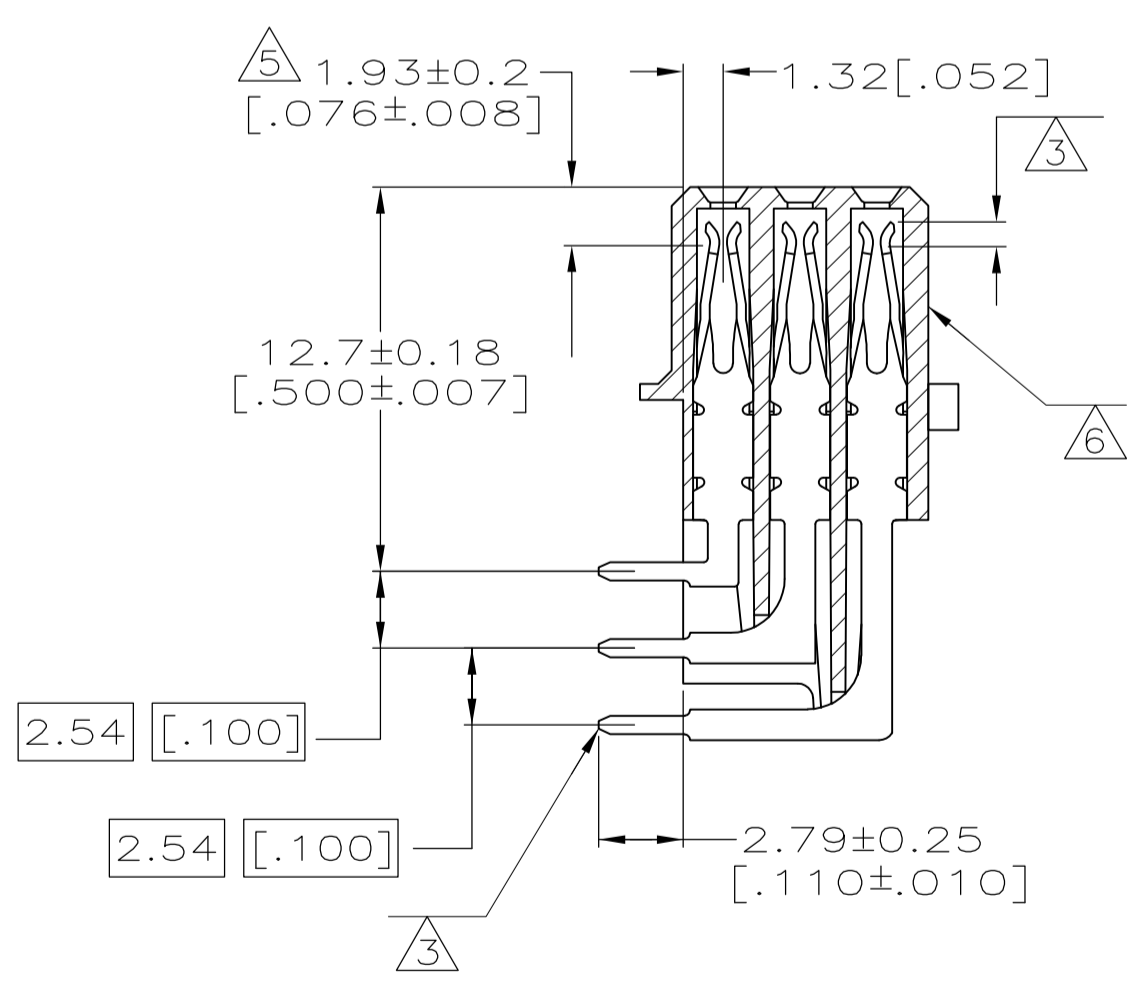
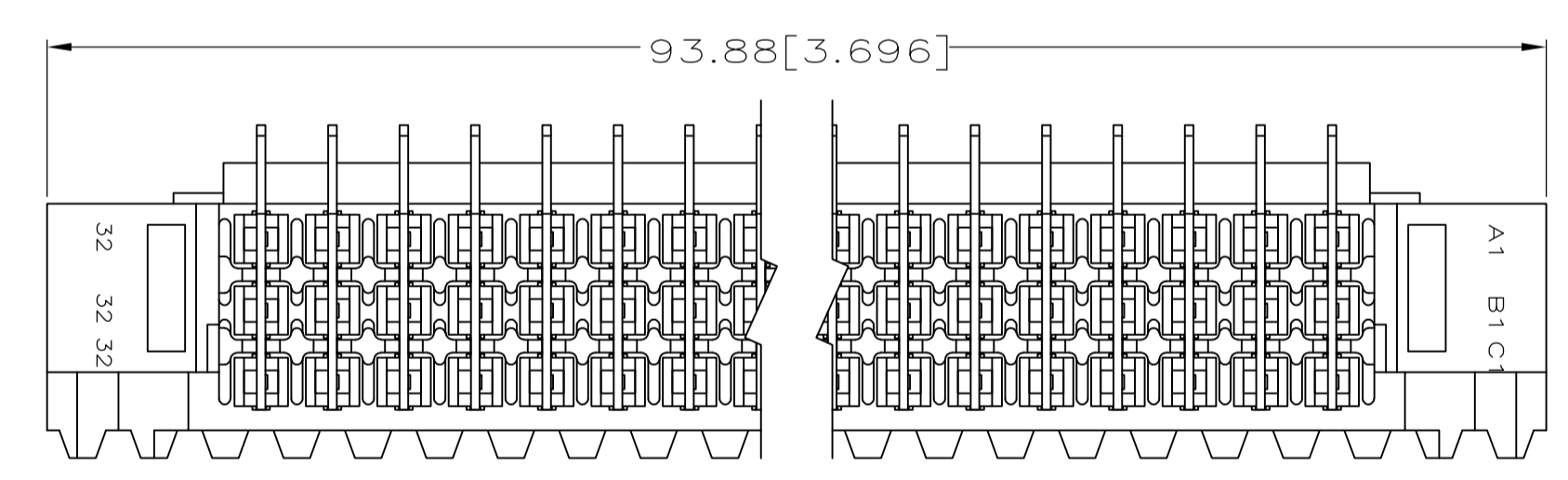
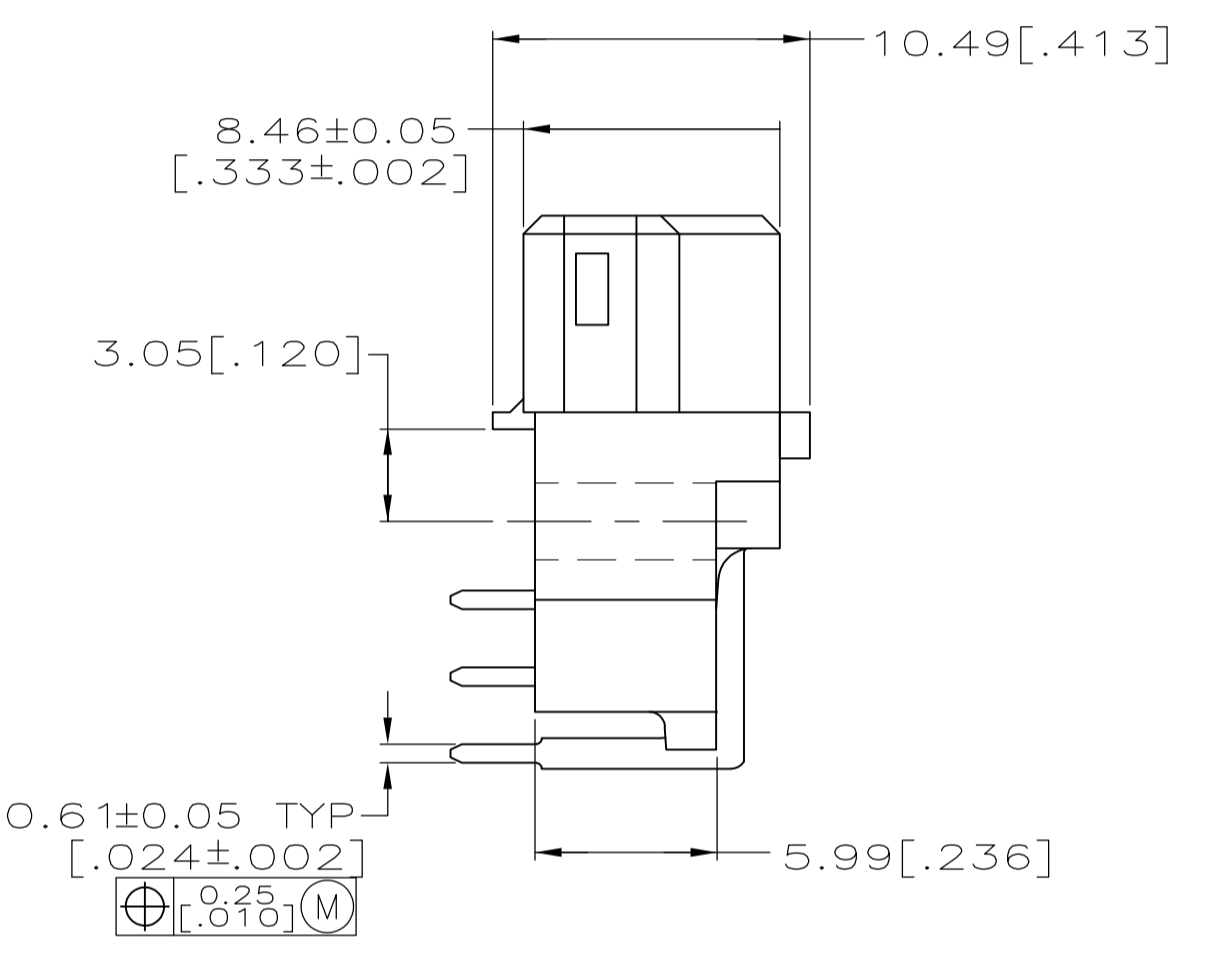
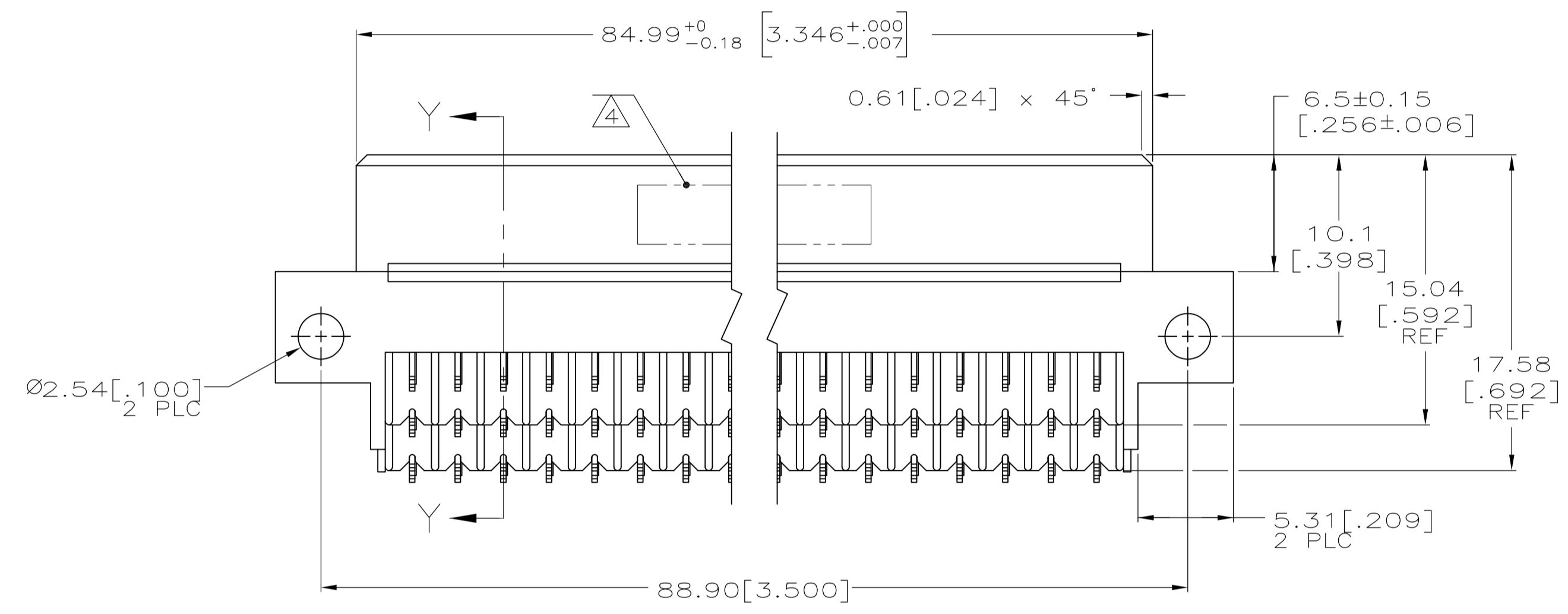
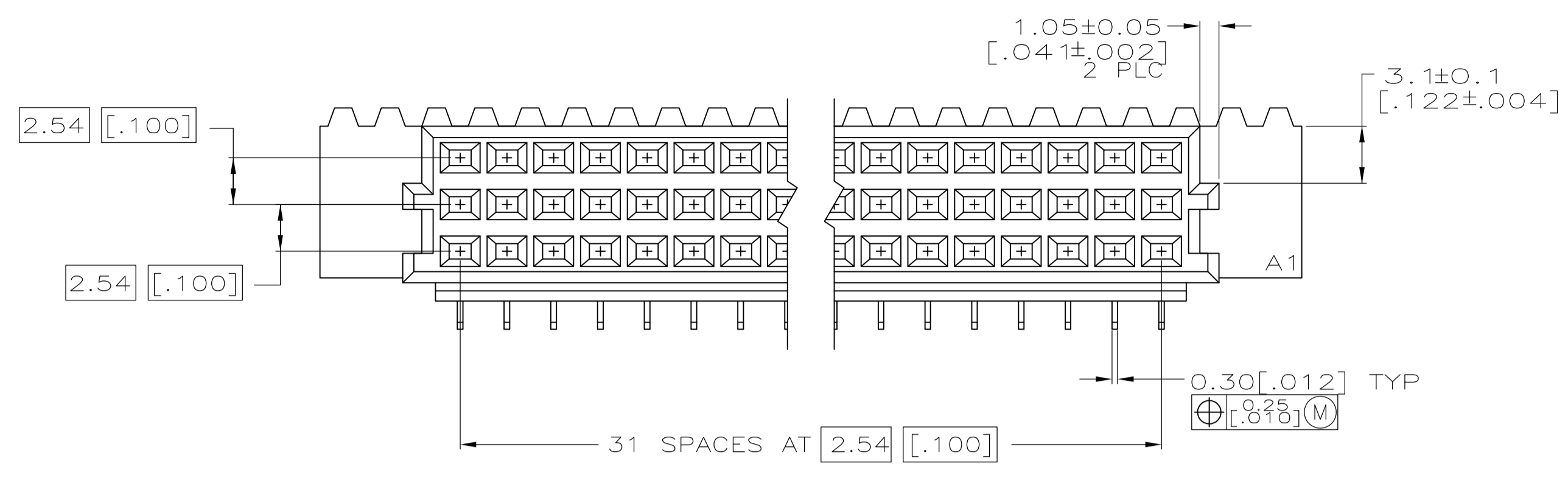

- △ HOUSING MATERIAL: GLASS-FILLED POLYMER.
- △ CONTACT MATERIAL: COPPER ALLOY.
- △ CONTACT FINISH: DIN 41612 CLASS 2 IN CONTACT AREA. TIN PLATE ON POSTS.
- △ PART NUMBER, DATE CODE IDENTIFICATION, CSA LOGO, THIS APPROXIMATE AREA.
- △ CONTACT POINT.
- △ MARKING ON THIS SIDE.
- △ RECOMMENDED HOLE SIZE FOR MANUAL APPLICATION OF CONNECTOR ONTO PC BOARD.

1 THRU 32	X	X	X	96	5650461-5
1 THRU 32	X	X	X	96	5650461-4
POSITIONS LOADED	C	B	A	NO. OF LOADED POSITIONS	ASSY PART NUMBER

THIS DRAWING IS A CONTROLLED DOCUMENT.

DIMENSIONS: mm [INCHES]	TOLERANCES UNLESS OTHERWISE SPECIFIED:	DIN J. POLIGNONE 03JUN05	DRW A. SHARPE 03JUN05	NAME ASSEMBLY, RECEPTACLE, EUROCARD, TYPE R, LEAD-FREE, 96 POSITION, 2.79[.110] SOLDER POSTS
0 PLC ± -	1 PLC ± -	2 PLC ± 0.13[.005]	3 PLC ± -	APPLICATION SPEC
4 PLC ± -	ANGLES ± -	FINISH	WEIGHT	SIZE A1
MATERIAL	FINISH	WEIGHT	SCALE 4:1	SHEET 1 of 1
CUSTOMER DRAWING		DRAWING NO. 00779		REV P

STE TE Connectivity