

1-390261-8 Product Details

[Share](#) [Print](#) [Email](#)

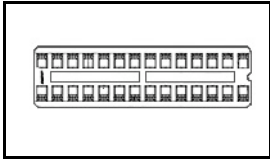

1-390261-8

TE Internal Number: 1-390261-8

 Active

[View 3D PDF](#)

DIP Sockets

 Always EU RoHS/ELV Compliant
(Statement of Compliance)

Product Highlights:

- Socket Style = Standard
- Through Hole Contact Termination Type
- 2.54 mm Centerline
- Row-to-Row Spacing = 7.62 mm
- 24 Positions

[View all Features](#)

Quick Links

- ▶ [Pricing & Availability](#)
- ▶ [Search for Tooling](#)
- ▶ [Product Feature Selector](#)
- ▶ [Contact Us About This Product](#)

[Add to My Part List](#)

[Request Sample](#)

[Find Similar Products](#)

[Buy Product](#)

Documentation & Additional Information

Product Drawings:

- [DIP SOCKET, .300 CENTER LINE LADDER STYLE \(PDF, English\)](#)

Catalog Pages/Data Sheets:

- None Available

Product Specifications:

- None Available

Application Specifications:

- None Available

Instruction Sheets:

- None Available

CAD Files: [\(CAD Format & Compression Information\)](#)

- [2D Drawing \(DXF, Version M\)](#)
- [3D Model \(IGES, Version M\)](#)
- [3D Model \(STEP, Version M\)](#)

[List all Documents](#)

Additional Information:

- [Product Line Information](#)

Related Products:

- [Tooling](#)

Product Features (Please use the Product Drawing for all design activity)

Product Type Features:

- [Socket Style](#) = Standard
- [Profile](#) = Standard
- [Frame Style](#) = Ladder
- [Leg Style](#) = Straight
- [PCB Mounting Orientation](#) = Horizontal

Electrical Characteristics:

- [Insulation Resistance \(MΩ\)](#) = 10,000
- [Contact Resistance \(mΩ\)](#) = 30

Termination Features:

- [Contact Termination Type](#) = Through Hole
- [Termination Post Length \(mm \[in\]\)](#) = 3.00 [0.118]

Dimensions:

- [Height Above PC Board \(mm \[in\]\)](#) = 5.10 [0.200]

Body Features:

Housing Features:

- [Centerline \(mm \[in\]\)](#) = 2.54 [0.100]

Configuration Features:

- [Number of Positions](#) = 24

Industry Standards:

- [RoHS/ELV Compliance](#) = RoHS compliant, ELV compliant
- [Lead Free Solder Processes](#) = Wave solder capable to 240°C, Wave solder capable to 260°C, Wave solder capable to 265°C
- [RoHS/ELV Compliance History](#) = Always was RoHS compliant

Conditions for Usage:

- [Temperature Range \(°C\)](#) = -40 - +105

Packaging Features:

- [Row-to-Row Spacing \(mm \[in\]\) = 7.62 \[0.300\]](#)
- [Mount Style = Vertical](#)

Contact Features:

- [Contact Base Material = Phosphor Bronze](#)
- [Contact Plating, Mating Area, Material = Tin](#)
- [Contact Style = Stamped + Formed](#)
- [Mating Contact Type = Dual Leaf](#)

- [Packaging Method = Tube](#)

Other:

- [Brand = AMP](#)

Corporate Information

- [About TE](#)
- [Investors](#)
- [News Room](#)
- [Supplier Portal](#)
- [Careers](#)
- [Terms & Conditions](#)
- [Privacy Policy](#)

Quick Links

- [Distributor Inventory](#)
- [Product Cross Reference](#)
- [Documents & Drawings](#)
- [Product Compliance Support Center](#)
- [Site Map](#)

Customer Support

- [Email or Chat With Us](#)
- [Find a Phone Number](#)
- [Knowledge Base](#)
- [Manage Your Account](#)

Keep Me Informed



THIS DRAWING IS UNPUBLISHED. RELEASED FOR PUBLICATION
 © COPYRIGHT - By - ALL RIGHTS RESERVED.

LOC		DIST		REVISIONS			
P	LTR	DESCRIPTION		DATE	DWN	APVD	
AD	0	M1	REVISED PER ECO-11-004587		11MAR11	RK	HMR

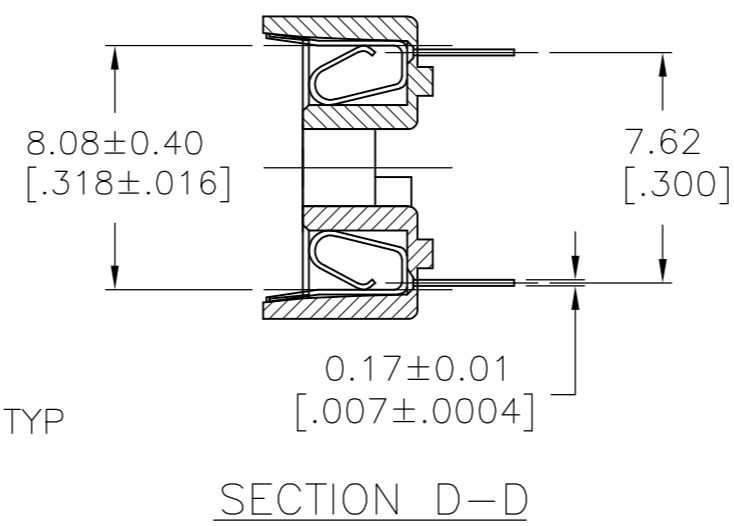
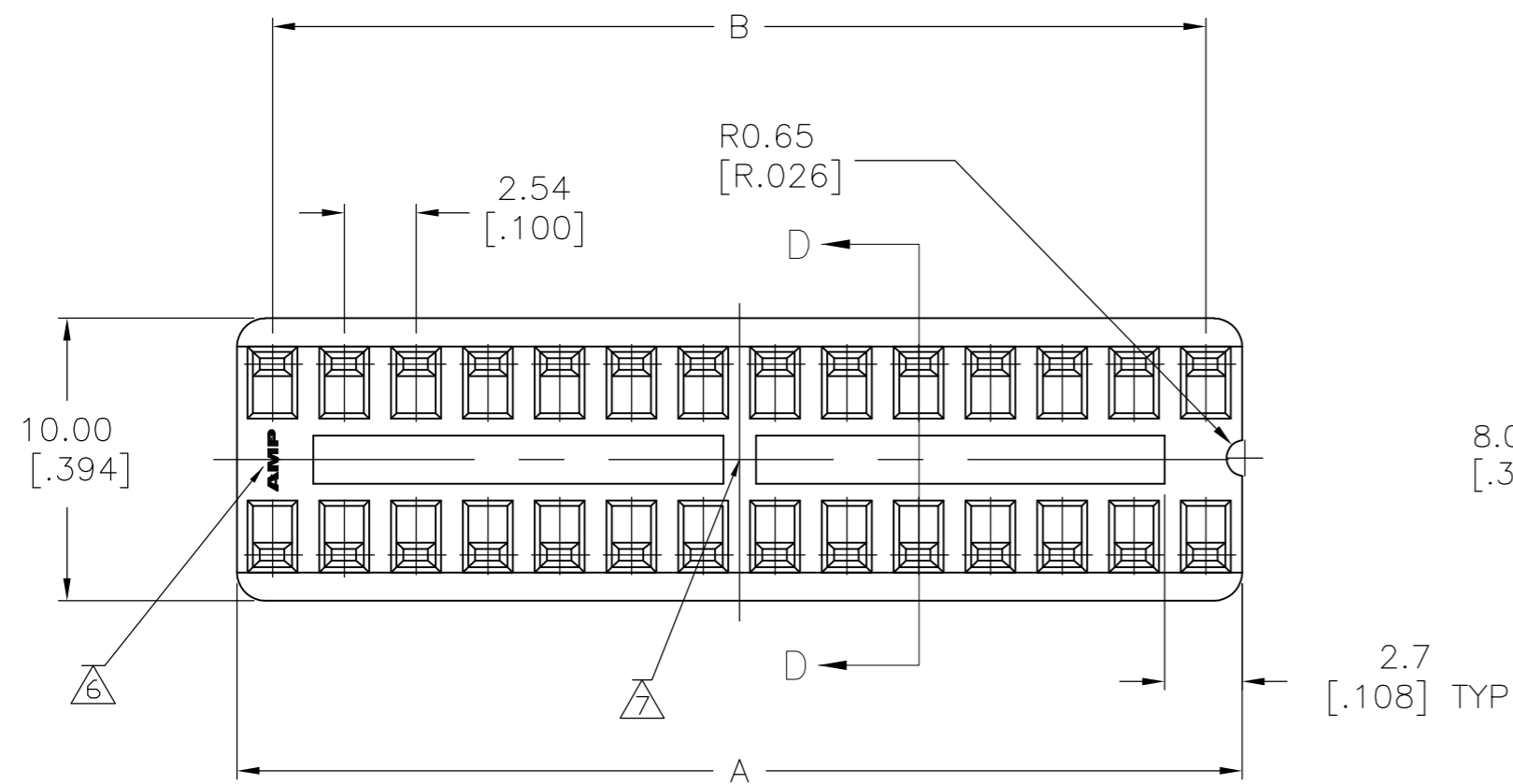

NOTE:

- 1 MATERIAL:
HOUSING: 30% GLASS FILLED PBT, THERMOPLASTIC, BLACK.
CONTACT: PHOS BRONZE
- 2 FINISH: CONTACT PLATING: TIN-LEAD (60u INCHES MIN.)
SOLDERABILITY :95% COVERAGE MIN.;
TEST TEMPERATURE=230°C±5°C
TEST TIME = 5±5 SECONDS.
- 3. MECHANICAL SPECS:
DURABILITY: 50 CYCLES MIN.
INSERTION FORCE:300 GRAMS MAX.
WITHDRAWAL FORCE: 20 GRAMS MIN.
CONTACT RETENTION: 500 GRAMS MIN.
ACCEPTS: 0.20-0.30 [.008-.012] LEADS
- 4. ELECTRICAL SPECS:
VOLTAGE RATING: 250V AC,DC
CONTACT RESISTANCE: 20 MILLOHMS MAX.
CURRENT RATING: 1 AMPERE AC,DC
INSULATION RESISTANCE: 1000 MEGOHMS MIN.
DIELECTRIC WITHSTANDING VOLTAGE: AC 1000 V MIN.
- 5. OPERATING TEMPERATURE: -40°C TO +105°C
- 6 AMP LOGO
- 7 LADDER PRESENT FOR 24, 28 & 32 POSITION SOCKETS.
- 8 FINISH: CONTACT PLATING TIN (LEAD FREE); 60 UIN MIN. OVER 30 UIN Ni
SOLDERABILITY :95% COVERAGE MIN.;
TEST TEMPERATURE=260°±5°C;
TEST TIME = 5±5 SECONDS.

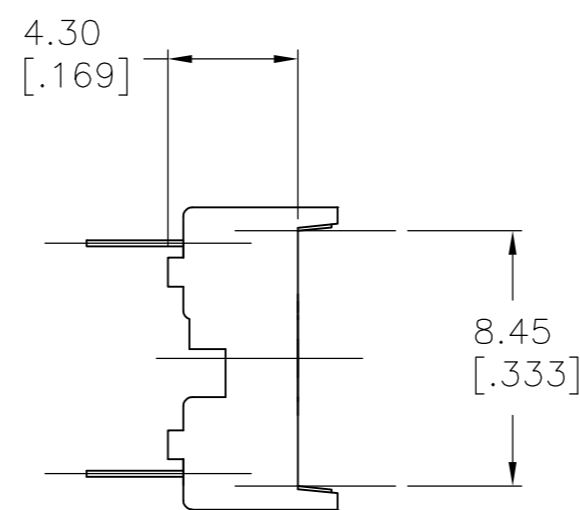
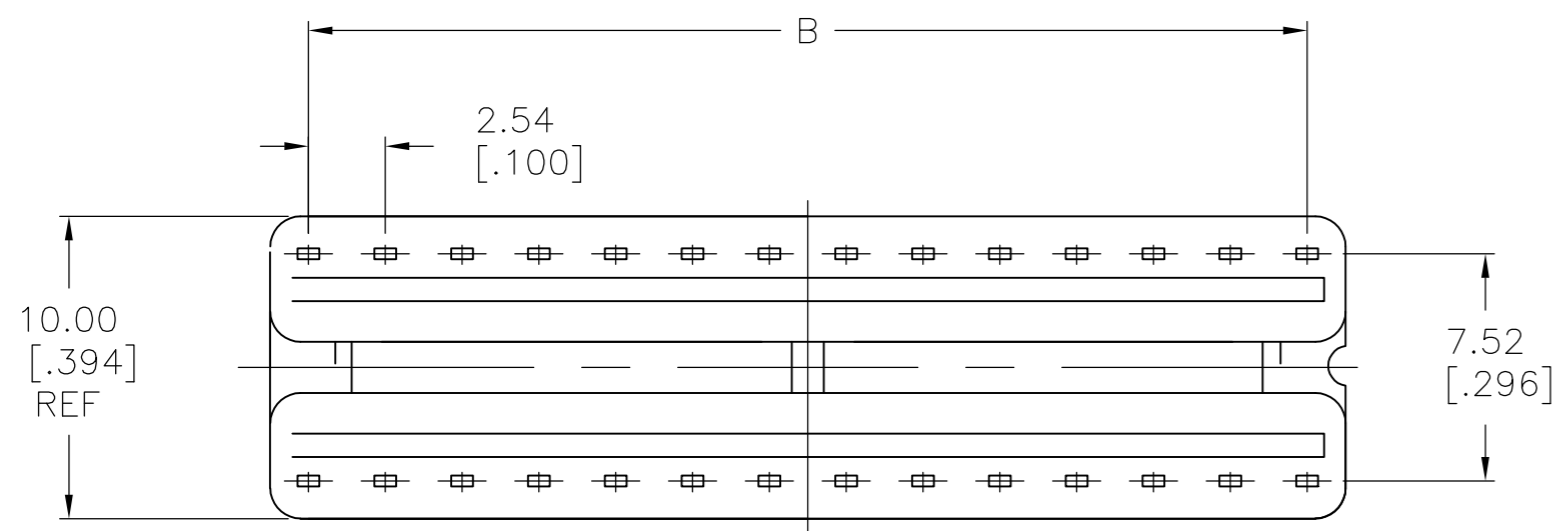
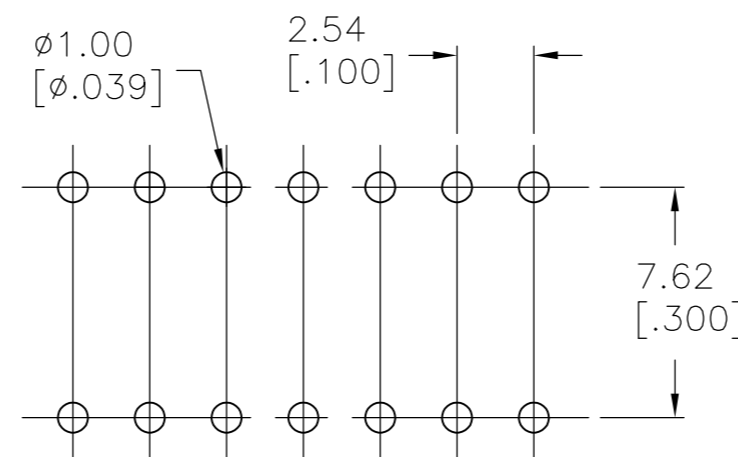
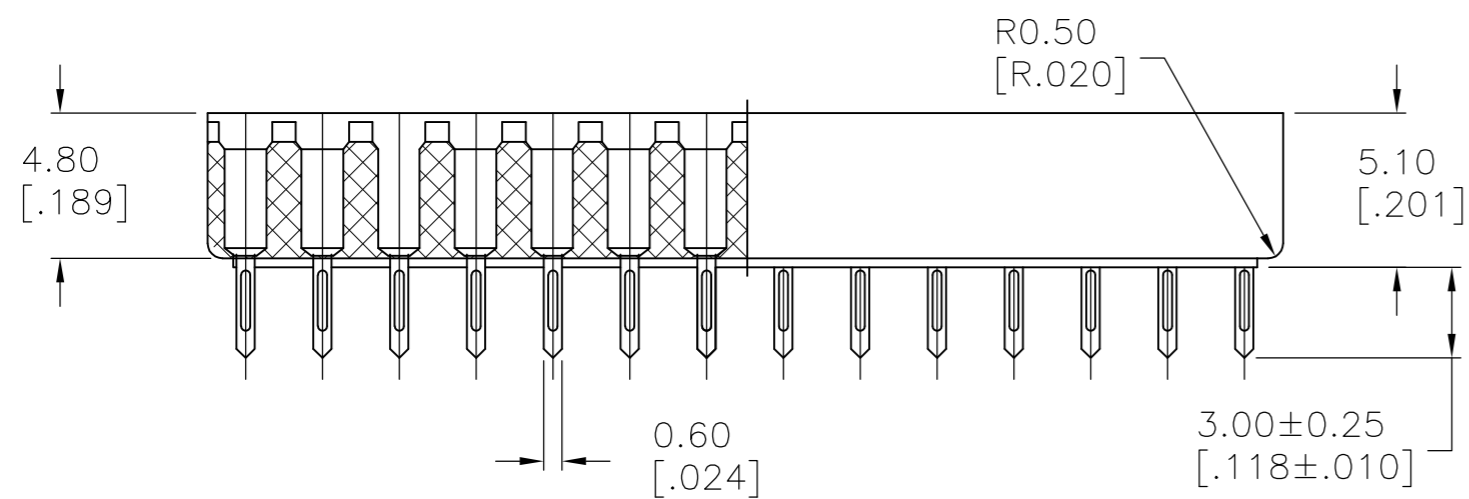

FINISH	POS	A ±0.20 [.008]	B±0.15 [.006]	PART NO.
8	32	40.64 [1.600]	38.10 [1.500]	2-390261-0
8	28	35.56 [1.400]	33.02 [1.300]	1-390261-9
8	24	30.48 [1.200]	27.94 [1.100]	1-390261-8
8	22	27.94 [1.100]	25.40 [1.000]	1-390261-7
8	20	25.40 [1.000]	22.86 [.900]	1-390261-6
8	18	22.86 [.900]	20.32 [.800]	1-390261-5
8	16	20.32 [.800]	17.78 [.700]	1-390261-4
8	14	17.78 [.700]	15.24 [.600]	1-390261-3
8	8	10.16 [.400]	7.62 [.300]	1-390261-2
8	6	7.62 [.300]	5.08 [.200]	1-390261-1
2	32	40.64 [1.600]	38.10 [1.500]	1-390261-0
2	28	35.56 [1.400]	33.02 [1.300]	390261-9
2	24	30.48 [1.200]	27.94 [1.100]	390261-8
2	22	27.94 [1.100]	25.40 [1.000]	390261-7
2	20	25.40 [1.000]	22.86 [.900]	390261-6
2	18	22.86 [.900]	20.32 [.800]	390261-5
2	16	20.32 [.800]	17.78 [.700]	390261-4
2	14	17.78 [.700]	15.24 [.600]	390261-3
2	8	10.16 [.400]	7.62 [.300]	390261-2
2	6	7.62 [.300]	5.08 [.200]	390261-1

SUPERSEDED BY 2-390261-0
 SUPERSEDED BY 1-390261-9
 SUPERSEDED BY 1-390261-8
 SUPERSEDED BY 1-390261-7
 SUPERSEDED BY 1-390261-6
 SUPERSEDED BY 1-390261-5
 SUPERSEDED BY 1-390261-4
 SUPERSEDED BY 1-390261-3
 SUPERSEDED BY 1-390261-2
 SUPERSEDED BY 1-390261-1

THIS DRAWING IS A CONTROLLED DOCUMENT.		DWN BSV	06SEP2004	
DIMENSIONS: mm [INCHES]		CHK -	NAME	
TOLERANCES UNLESS OTHERWISE SPECIFIED:		APVD -	PRODUCT SPEC	
0 PLC ± -		PRODUCT SPEC	APPLICATION SPEC	
1 PLC ± -		APPLICATION SPEC	-	
2 PLC ± 0.2 [.008]		WEIGHT -	SIZE A2	CAGE CODE 00779
3 PLC ± -		CUSTOMER DRAWING	DRAWING NO C=390261	RESTRICTED TO -
4 PLC ± -			SCALE 4:1	SHEET 1 OF 1
ANGLES ± -			REV M1	
FINISH				



DIP SOCKET, .300 CENTER LINE
LADDER STYLE