

CHS

SLIDE SWITCHES (HALF PITCH)

RoHS compliant

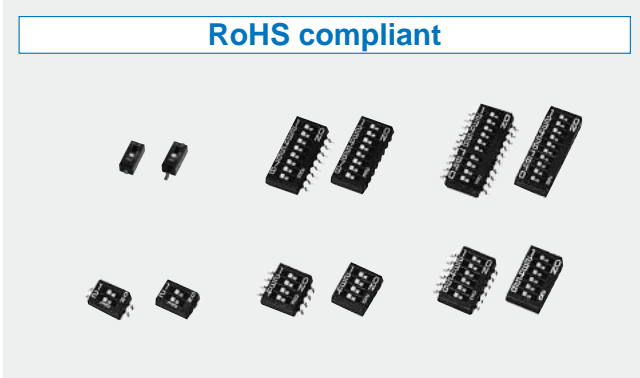

FEATURES

- RoHS compliant
- Meets EIAJ SOP standard outline dimensions (B type)
- Low profile design of 2.5 mm
- 12 types of 1, 2, 4, 6, 8 or 10 bit with either gull wing or J-hook available
- Excellent contact stability by twin Gold-plated contact

INTERNAL STRUCTURE

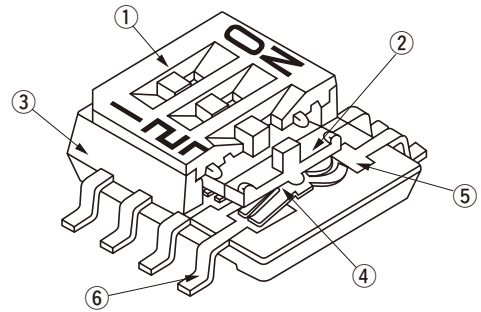

Part name	Material	Flammability
① Cover	Polyphenylenesulphide	UL-94V-0
② Slider	Polyamide	
③ Housing	Polyphenylenesulphide	—
④ Slider contact	Copper alloy, Gold-plated	
⑤ Fixed contact		
⑥ Terminal pin		

CFCs, Halon, Carbon tetrachloride and designated bromic flame retardant PBBOs and PBBs are not used in our products.

PART NUMBER DESIGNATION

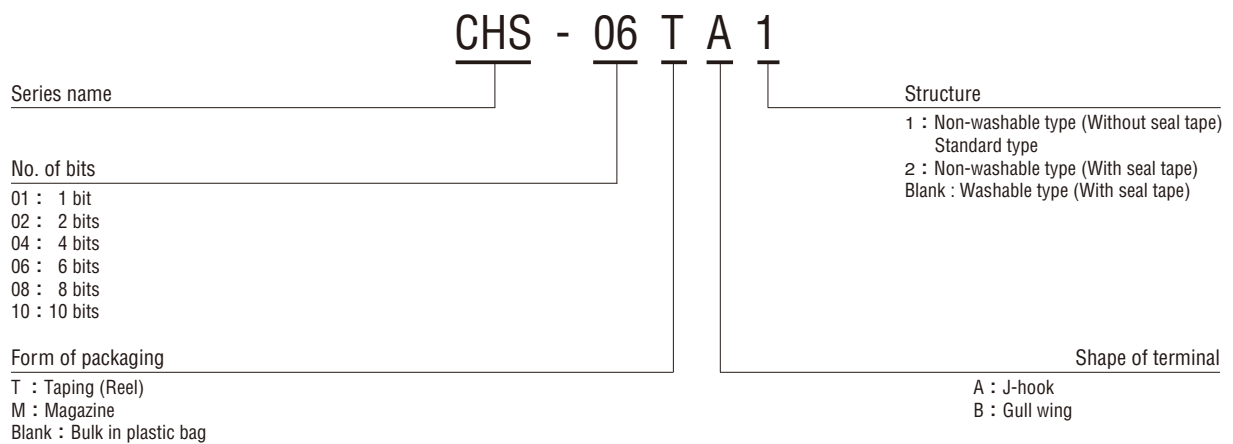

LIST OF PART NUMBERS

No. of bits	Form of packaging	Shape of terminals	Non-washable type (Without seal tape)		Non-washable type (With seal tape)		Pieces in package
			A (J-hook)	B (Gull wing)	A (J-hook)	B (Gull wing)	
1	Taping		CHS-01TA1	CHS-01TB1	CHS-01TA2	CHS-01TB2	1000 pcs./reel
	Magazine						
	Plastic bag		CHS-01A1	CHS-01B1			50 pcs./pack
2	Taping		CHS-02TA1	CHS-02TB1	CHS-02TA2	CHS-02TB2	500 pcs./reel
	Magazine						
	Plastic bag		CHS-02A1	CHS-02B1			50 pcs./pack
4	Taping		CHS-04TA1	CHS-04TB1	CHS-04TA2	CHS-04TB2	500 pcs./reel
	Magazine		CHS-04MA1	CHS-04MB1			70 pcs./stick
	Plastic bag		CHS-04A1	CHS-04B1			50 pcs./pack
6	Taping		CHS-06TA1	CHS-06TB1	CHS-06TA2	CHS-06TB2	500 pcs./reel
	Magazine		CHS-06MA1	CHS-06MB1			50 pcs./stick
	Plastic bag		CHS-06A1	CHS-06B1			50 pcs./pack
8	Taping		CHS-08TA1	CHS-08TB1	CHS-08TA2	CHS-08TB2	500 pcs./reel
	Magazine		CHS-08MA1	CHS-08MB1			40 pcs./stick
	Plastic bag		CHS-08A1	CHS-08B1			50 pcs./pack
10	Taping		CHS-10TA1	CHS-10TB1	CHS-10TA2	CHS-10TB2	500 pcs./reel
	Magazine		CHS-10MA1	CHS-10MB1			30 pcs./stick
	Plastic bag		CHS-10A1	CHS-10B1			50 pcs./pack

No. of bits	Form of packaging	Shape of terminals	Washable type (With seal tape)		Pieces in package
			A (J-hook)	B (Gull wing)	
1	Taping		CHS-01TA	CHS-01TB	1000 pcs./reel
	Magazine				
	Plastic bag		CHS-01A	CHS-01B	50 pcs./pack
2	Taping		CHS-02TA	CHS-02TB	500 pcs./reel
	Magazine				
	Plastic bag		CHS-02A	CHS-02B	50 pcs./pack
4	Taping		CHS-04TA	CHS-04TB	500 pcs./reel
	Magazine		CHS-04MA	CHS-04MB	70 pcs./stick
	Plastic bag		CHS-04A	CHS-04B	50 pcs./pack
6	Taping		CHS-06TA	CHS-06TB	500 pcs./reel
	Magazine		CHS-06MA	CHS-06MB	50 pcs./stick
	Plastic bag		CHS-06A	CHS-06B	50 pcs./pack
8	Taping		CHS-08TA	CHS-08TB	500 pcs./reel
	Magazine		CHS-08MA	CHS-08MB	40 pcs./stick
	Plastic bag		CHS-08A	CHS-08B	50 pcs./pack
10	Taping		CHS-10TA	CHS-10TB	500 pcs./reel
	Magazine		CHS-10MA	CHS-10MB	30 pcs./stick
	Plastic bag		CHS-10A	CHS-10B	50 pcs./pack

☐ : Not manufactured

※ Verify the above part numbers when placing orders.

Taping and magazine version can be supplied only in reel or stick units.

STANDARD SPECIFICATIONS

Operating temp. range	- 40 ~ 85 °C
Storage temp. range	
Sealing	Washable type available with seal tape
Net weight	Approx. 0.05 g (CHS-01) Approx. 0.08 g (CHS-02) Approx. 0.12 g (CHS-04) Approx. 0.17 g (CHS-06) Approx. 0.22 g (CHS-08) Approx. 0.25 g (CHS-10)

ELECTRICAL CHARACTERISTICS

Contact rating Non-switching Switching Minimum	DC50 V 100 mA DC6 V, 100 mA DC24 V, 25 mA DC20 mV 1 μA
Contact resistance	50 mΩ maximum
Insulation resistance	1000 MΩ (DC100 V) minimum
Dielectric strength	AC500 V, 60 s

MECHANICAL CHARACTERISTICS

Operating force	0.5 ~ 5 N {0.05 ~ 0.51 kgf}
Stop strength	10 N {1.02 kgf}, 60 s
Solderability	245 ± 3 °C, 2 ~ 3 s
Soldering heat	Reflow : 255 °C (Peak temperature) (Please refer to the profile below)
	Manual soldering : 350 ± 10 °C, 3 ~ 4 s
Shear (Adhesion)	5 N {0.51 kgf} 10 s
Substrate bending	Width 90 mm, bend 3 mm, 5 s, 1 time
Pull-off strength	5 N {0.51 kgf} 10 s

ENVIRONMENTAL CHARACTERISTICS

Vibration	Amplitude 1.5 mm or Acceleration 98 m/s ² , 10-500 Hz, 3 directions for 10 cycles each
Shock	490 m/s ² , 11 ms 6 directions for 3 times each
Load life	Continuous load 2000 cycles, DC6 ± 0.5 V, 100 ± 10 mA
Humidity	-10 ~ 65 °C, Relative humidity 0 ~ 96 %, 24 h for 10 cycles
High temp. exposure	85 °C, 96 h
Low temp. exposure	-40 °C, 96 h
Thermal shock	-40 (0.5 h) ~ 85 °C (0.5 h), 5 cycles

{ } : Reference only

Reflow profile for soldering heat evaluation

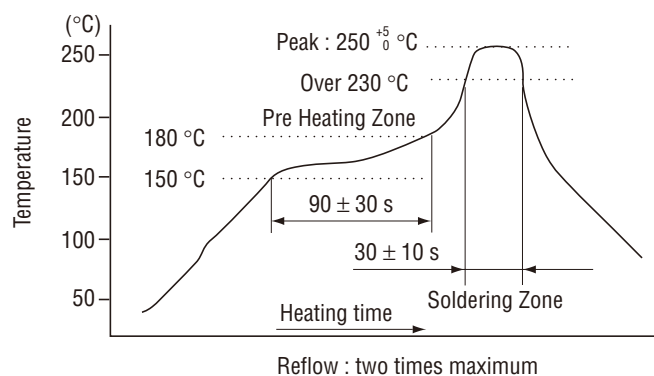

CHS SLIDE SWITCHES (HALF PITCH)

OUTLINE DIMENSIONS

Unless otherwise specified, tolerance : ± 0.3 (Unit : mm)

- **CHS-04A**
Washable type (With seal tape)
- **CHS-04TA2**
Non-washable type (With seal tape)

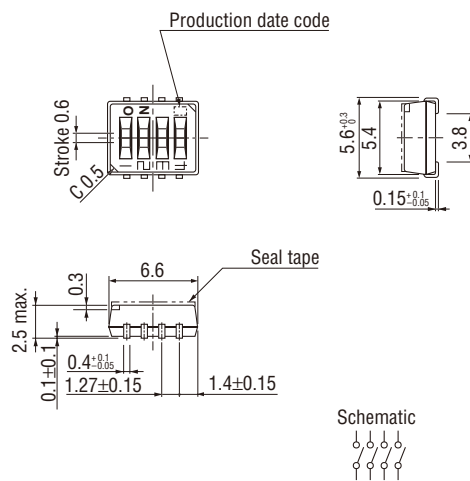

- **CHS-04B**
Washable type (With seal tape)
- **CHS-04TB2**
Non-washable type (With seal tape)

(In accordance with EIAJ ED-7402-1)

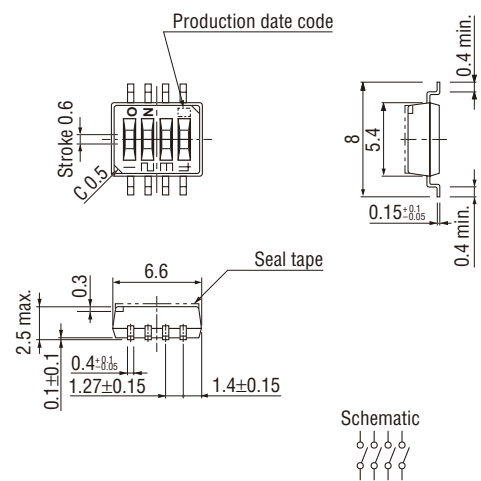

- **CHS-06A**
Washable type (With seal tape)
- **CHS-06TA2**
Non-washable type (With seal tape)

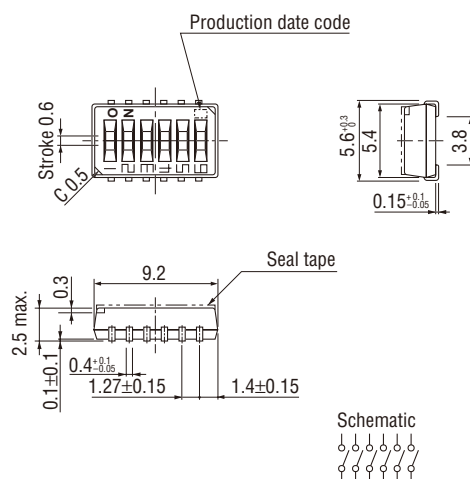

- **CHS-06B**
Washable type (With seal tape)
- **CHS-06TB2**
Non-washable type (With seal tape)

(In accordance with EIAJ ED-7402-1)

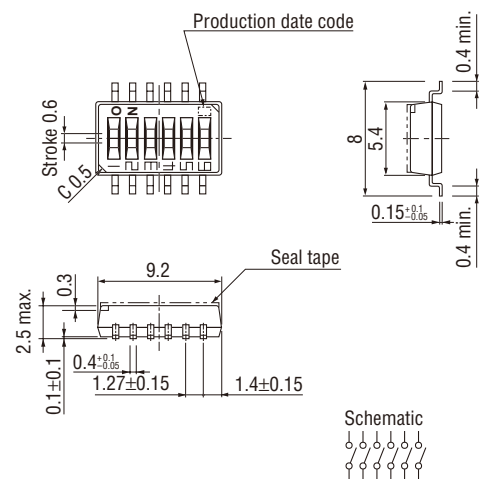

RECOMMENDED P.C.B. PAD OUTLINE DIMENSIONS

● 4 bits

(Unit : mm)

A type

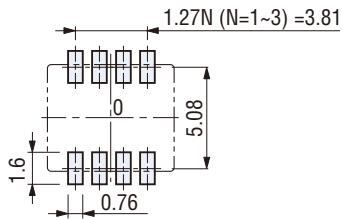

B type

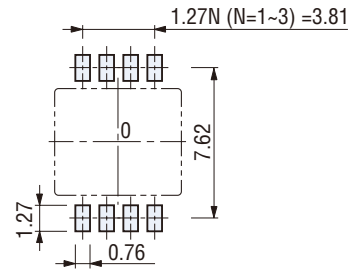

● 6 bits

A type

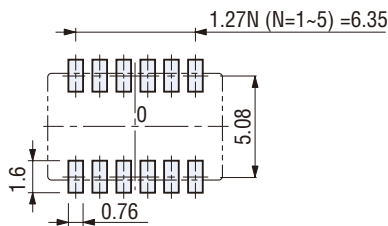

B type

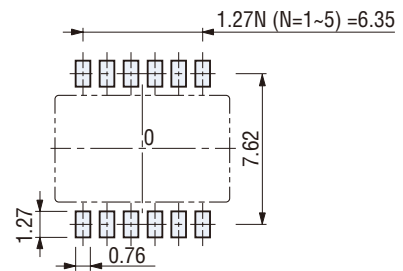

● 8 bits

A type

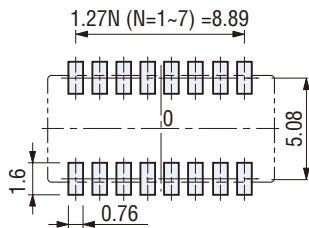

B type

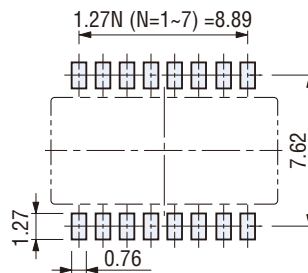

● 10 bits

A type

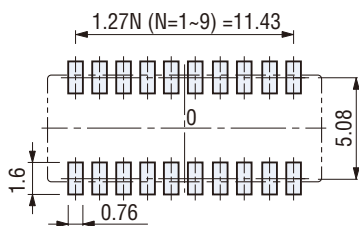

B type

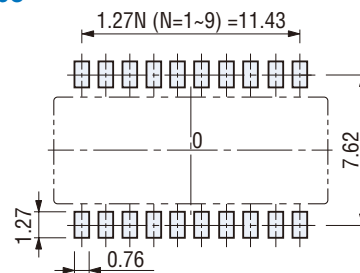

Note) The zero point is the center of mounting.

CHS
SLIDE SWITCHES (HALF PITCH)

● 4 bits

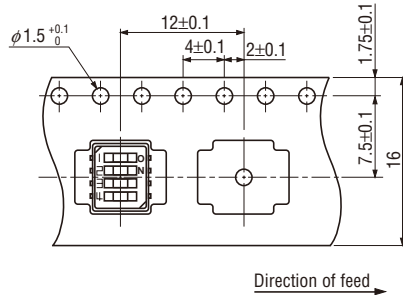

(Conforms to JIS C 0806)

(Unit : mm)

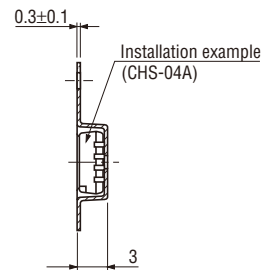

● 6 bits

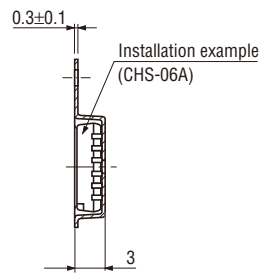
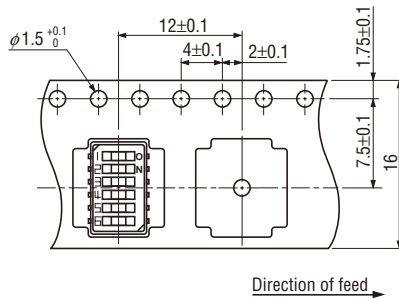

● 8 bits

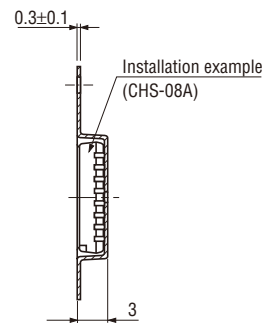
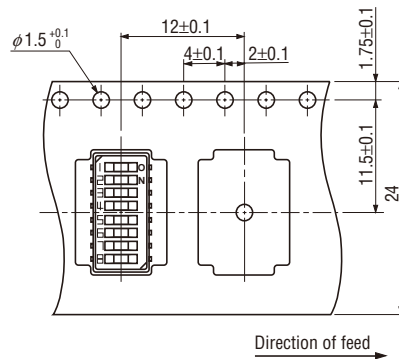

● 10 bits

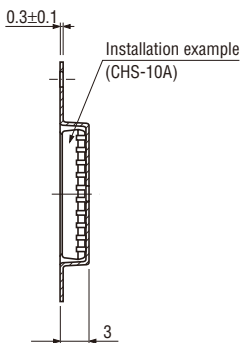
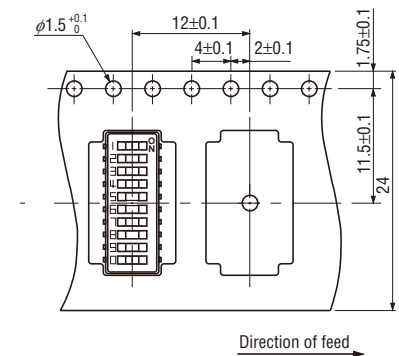

<Magazine packaging specifications>

- Packing quantities of magazines are different depending on the bit number of the switches.
Please order the multiple numbers of the specific packing quantities.
(e.g. 70 pcs., 140 pcs., 210 pcs., etc., in case of 4 bits version)

Pieces in package : 4 bits, 70pcs./stick
 6 bits, 50pcs./stick
 8 bits, 40pcs./stick
 10 bits, 30pcs./stick

● Magazine dimensions

(Unit : mm)

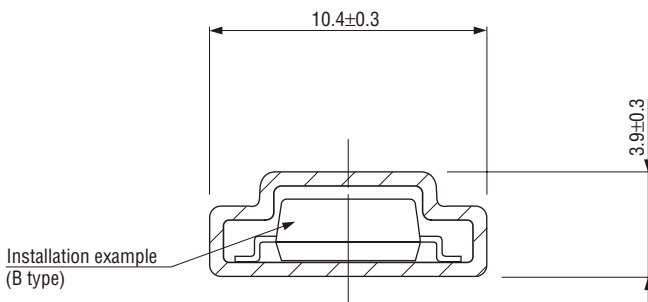

※The magazine is common to A and B terminal pin.
 Magazine length : 500 ± 2 mm long

<Bulk pack specifications>

- The smallest unit of bulk pack in a plastic bag is 10 pcs. per pack.
Orders will be accepted for unit of minimum 10 pcs., i.e., 10, 20, 30 pcs., etc.
- Boxing of bulk in a plastic bag is performed with 50 pcs. (standard 200 pcs.) per box.