



Conforms to EN292, EN60204-1, EN954-1, EN1088, EN60947-5-3, EN947-5-3, EN50081, EN50082, EN61000-6-2
UL and C-UL listed, TÜV certified

■ **Description**

The CM switches are tamper resistant non-contact safety interlock switches that operate with their own control units except for the CM-S221 switch. The CM-S221 switch will work with many safety monitoring relays accepting 2 N/C safety inputs. The CM control units will monitor one to four CM switches to category 3 in accordance with EN954-1.

The CM-S4 controller is designed to work with with non-contact switches with dry contacts 1 N/C + 1 N/O. The CM-S21 and CM-S41 controllers and the CM-SE expansion module are designed to only accept CM-S11 and CM-S31 switches. These controllers sense voltage and current changes in the switch circuit when the actuator is presented to the switch.

The CM control units provide EDM (External Device Monitoring, also called MPCE monitoring) and an automatic reset function. This allows the CM control units to replace a safety relay in most applications.

The NEMA 6 encapsulated design of the CM Series switch makes it ideal for harsh environments.

Mechanical switches and CM Series switches may be used together with a single CM-S4 control unit for applications requiring both non-contact and mechanical safety interlock switches.

The CM Series switch and actuator are available in four sizes plus a stainless steel version to accommodate a variety of application requirements.



G

safety interlock switches

CM Series

Compact Coded Magnetic Safety Interlock Switch and Control Units

- A fully monitored system that meets Category 3 when 1 to 30 plus switches are used with the CM Control Units
- External Device Monitoring (EDM) with monitored manual or automatic reset
- NEMA 6 switch enclosures satisfy most application requirements
- Magnetically coded switches are tamper resistant to common magnets
- Misalignment tolerance of (5 and 9 mm) reduces nuisance tripping
- Dual channel N/C E-stop input is monitored by the CM-S41 control in addition to four CM switches
- Mechanical interlock switches may be used with the CM-S4 control unit
- CM control units may replace a safety relay in most applications
- CM-S221 switches with 2 N/C safety contacts and 1 N/O auxiliary contact may be used with many other safety monitoring relays accepting 2 N/C safety inputs including the SR103AM; CM-S221 switches are not compatible with Legacy Relay products or the SR203M/AM, SR208AD or SR209AD

Actual Size

CM-S31 Read Head



CM-S2 and CM-S221 Read Heads



Operation

Operating Principle for Coded Magnetic Switch with Conventional Dry Contacts

On presenting the actuator to the switch, the coded, high intensity magnetic field from the actuator causes the contacts to close. On removing the actuator (opening the door), the safety contacts open, isolating the machine.

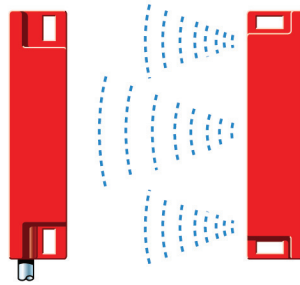

Mounting Examples

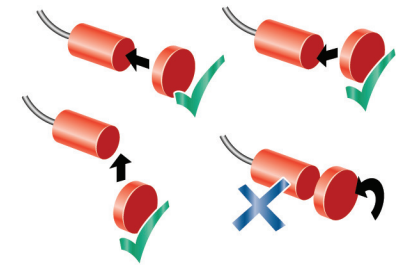
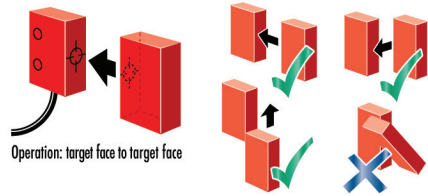

Contact Arrangements

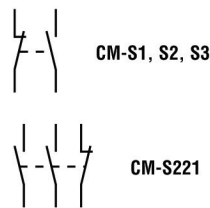

Note: The CM-S11 and CM-S31 switches are not conventional dry contacts.

NOTE: ACTUATOR MUST NOT STRIKE READ HEAD

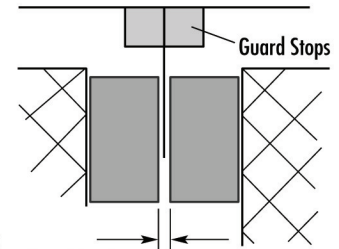

min 1 mm
max 2 mm - all read heads

Recommended gap between sensor and actuator.

Installation Alignments

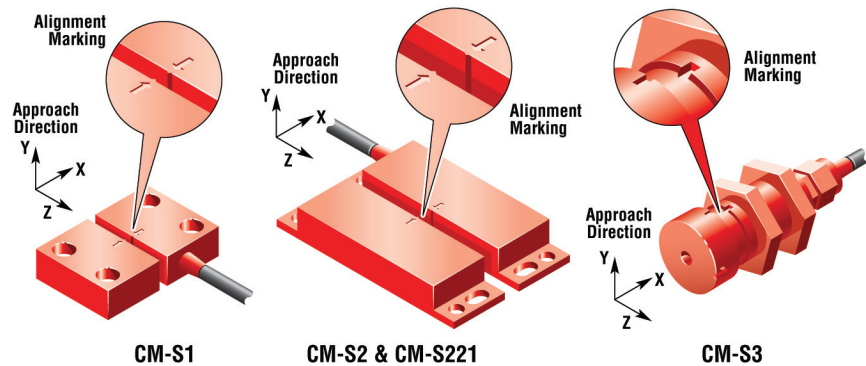

G safety interlock switches

Universal Mounting Brackets can be used with this product. See page G241 for details.

■ Applications

Typical applications are on sliding guard doors or swinging guard doors.

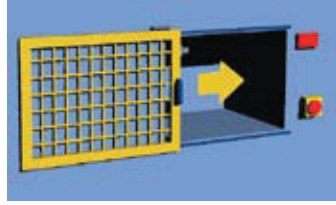

G

safety interlock switches

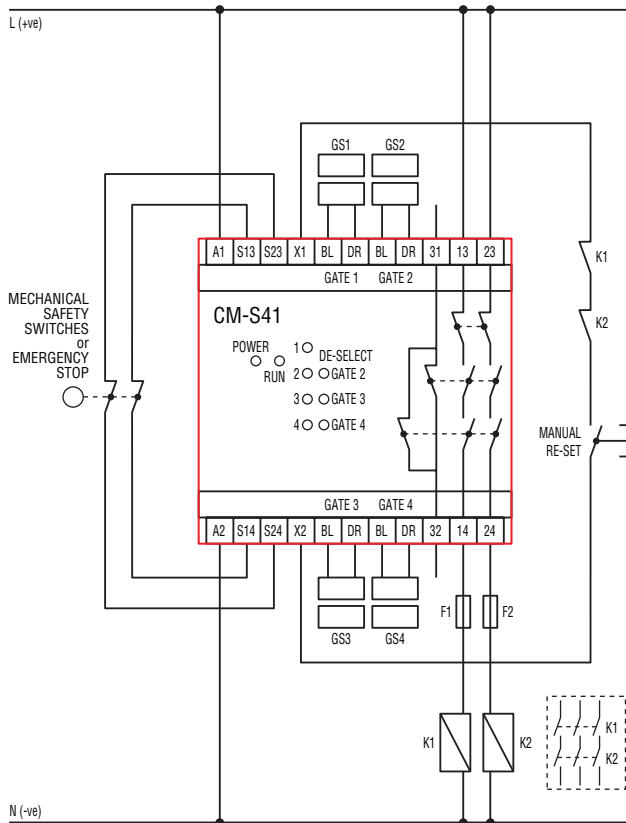

In the illustration above, the guard door is open and the machine is stopped. Machine will start when the guard door is closed, and the reset button is pressed.

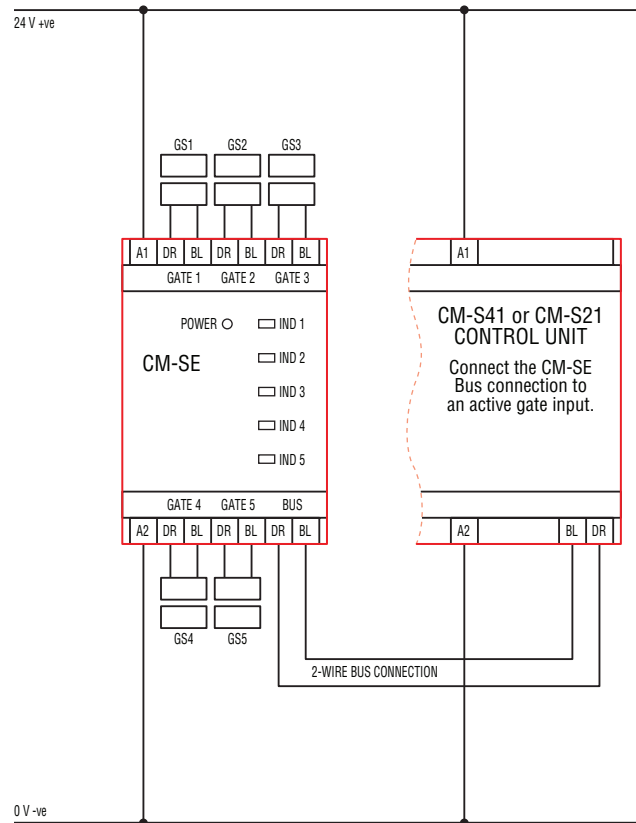

In the illustration above, all of the guard doors are open and the machine is stopped. Machine will start when all the guard doors are closed, and the reset button is pressed.

A **Go to the Engineering Guide**
For in-depth information on safety standards and use.

N **For More Guarding Products**
See Section N for safeguarding cutting and turning machines

■ Control Unit Specifications

Electrical	CM-S4	CM-S41, CM-S21 & CM-SE
Power Supply:	24 VAC/DC ± 10%	CM-S41 — 24 VAC/DC, 110 VAC CM-S21 & CM-SE — 24 VAC/DC
Power Consumption:	2.4 VA typical	CM-S41 — 6 VA; CM-S21 & CM-SE — 3 VA
External Fuse (Operating Voltage):	0.25 A quick acting	—
Input Fuse (Supply Voltage):	—	500 mA resettable
Safety Inputs:	1 N/O + 1 N/C	CM-S41 — 4 CM-S11 or CM-S31 switches CM-S21 — 2 CM-S11 or CM-S31 switches CM-SE — 5 CM-S11 or CM-S31 switches
Max Cable Length:	—	100 m (328 ft.)
Max Input Resistance:	Contact factory	
Min. Approach Speed:	Contact factory	
Relay Outputs:	1 N/O safety + 1 N/O aux.	CM-S41 & CM-S21 — 2 N/O; CM-SE — N/A
Auxiliary Contact of Controls:	4 A, 24 VAC/DC	CM-S41 & CM-S21 — 1 N/C; CM-SE — N/A
Max Switched Current/Voltage:	4 A / 24 VAC/DC	4 A / 230 VAC; 2 A / 24 VDC (resistive)
Min Switched Current/Voltage:	4 mA / 12 V	10 V / 10 mA
Impulse Withstand Voltage:	250 V	
Max Drop-Out Time:	18 ms	Deactivation by sensor 13 ms
Max Output Fuse:	4 A quick acting	AC = 5 A; DC = 2.5 A; quick acting
Reset Mode:	Automatic	Monitored manual or automatic
External Device Monitoring:	N/C loop between Y1 and Y2	N/C loop between X1 and X2
Mechanical		
Mounting:	35 mm (1.38 in.) DIN rail	35 mm (1.38 in.) DIN rail
Case Material:	Polycarbonate	Polycarbonate
Max Wire Size:	2 x 2.5 mm ² (12 AWG)	1 x 2.5 mm stranded, 1 x 4 mm solid
Weight:	240 g (8.5 oz.)	CM-S41 — 575 g (20.3 oz.) CM-S21 — 183 g (6.5 oz.) CM-SE — 135 g (4.8 oz.)
Color:	Gray	Red
Indication:	U: Green = On Outputs Open: Red = On Outputs Closed: Green = On D11, D12, D21, D22: Green = Gate closed D31, D32, D41, D42: Red = Gate open	Power = Red Outputs Closed: Green = On Outputs Open: No Light = Off Gate Closed: Yellow = On Gate Open: No Light = Off
Mechanical Life:	30 x 10 ⁶	10 x 10 ⁶
Environmental		
Protection:	IP40 (NEMA 1)	Housing IP40, Terminals IP20
Operating Temperature:	0 to 50°C (32 to 122°F)	10 to 55°C (50 to 131°F)
Humidity:	95% RH at 55°C (131°F)	85% max
Compliance		
Standards:	EN292, EN60204-1, EN954-1, EN1088, EN60947-5-3, EN947-5-3, EN50081, EN50082, EN61000-6-2	
Approvals/Listings:	CE marked for all applicable directives, UL and C-UL, TUV	
Safety Category:	Cat 3 per EN954-1 (internal operation)	

G
safety interlock switches

Specifications are subject to change without notice.

Note: The safety contacts of the Omron STI switches are described as normally closed (N/C) i.e., with the guard closed, actuator in place, and the machine able to be started.

■ Switch Specifications

Electrical	CM-S1, CM-S2, CM-S3	CM-S221	CM-S11	CM-S31
Safety Contacts:	1 N/C + 1 N/O	2 N/C + 1 N/O	Current Sensing Circuit	Current Sensing Circuit
N/C Operating Distance:	CM-S1 — On = 3 mm; Off = 8 mm CM-S2 and CM-S3 — On = 6 mm; Off = 13 mm	On = 7 mm; Off = 12 mm	On = 5-7 mm; Off = 8-12 mm	On = 5-7 mm; Off = 8-12 mm
Minimum Gap:		1 mm	1 mm	1 mm
Max Switched Current/Voltage:	500 mA / 24 V	300 mA / 24 V		
Mechanical				
Mounting:	2 x M4 screws supplied	2 x M4 screws supplied	2 x M4 screws supplied	2 x M4 screws supplied
Case Material:	Glass filled SPS	ABS	ABS	316 stainless steel
Max Wire Size:	Pre-wired cable to 5 m	Pre-wired cable to 5 m	Pre-wired cable various lengths	Pre-wired cable various lengths
Weight:	230 g (8.1 oz.)	230 g (8.1 oz.)	207 g (7.3 oz.)	265 g (9.3 oz.)
Color:	Red	Red	Red	Stainless
Mechanical Life:	100 x 10 ⁶	10 x 10 ⁶		
Environmental				
Protection:	IP67 (NEMA 6)	IP67 (NEMA 6)	IP67 (NEMA 6)	IP67 (NEMA 6)
Operating Temperature:	-20 to 60°C (-4 to 140°F)	-10 to 55°C (14 to 131°F)	10 to 55°C (50 to 131°F)	10 to 55°C (50 to 131°F)
Humidity:	95% RH at 55°C (131°F)			
Compliance				
Standards:	EN292, EN60204-1, EN954-1, EN1088, EN60947-5-3, EN947-5-3, EN50081, EN50082, EN61000-6-2			
Approvals/Listings:	CE marked for all applicable directives, UL and C-UL, TUV (TUV pending for CM-S221)			

Specifications are subject to change without notice.

Note: The safety contacts of the Omron ST1 switches are described as normally closed (N/C) i.e., with the guard closed, actuator in place, and the machine able to be started.

G

safety interlock switches

A **Go to the Engineering Guide**
For in-depth information on safety standards and use.

N **For More Guarding Products**
See Section N for safeguarding cutting and turning machines

■ Dimensions — mm/in.

Control Units

CM-S4

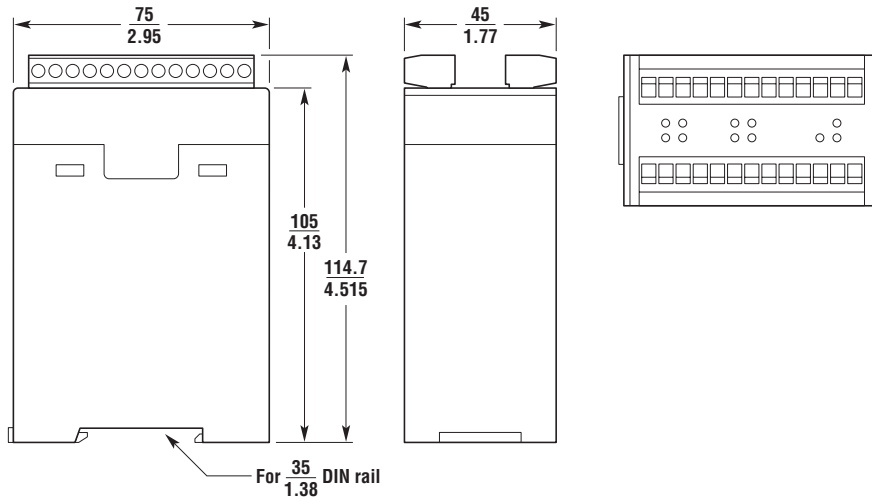

CM-S41

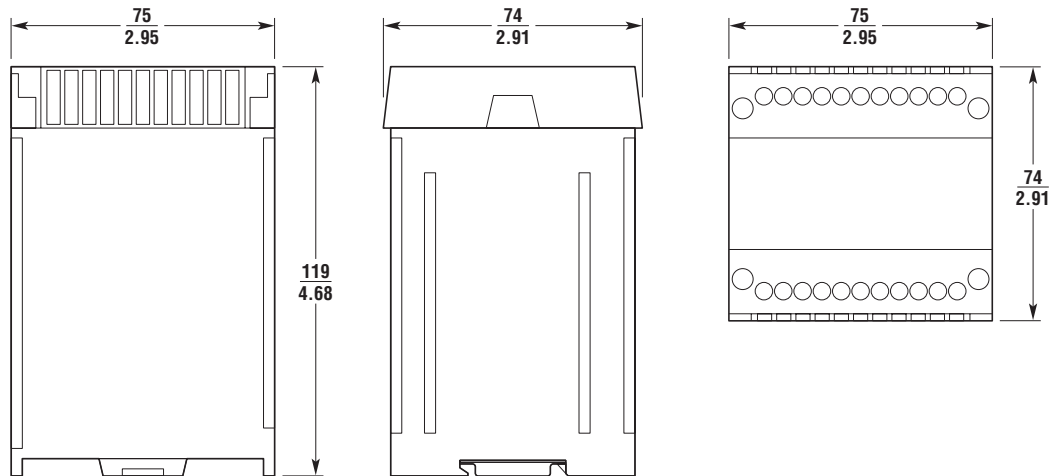

CM-S21/SE

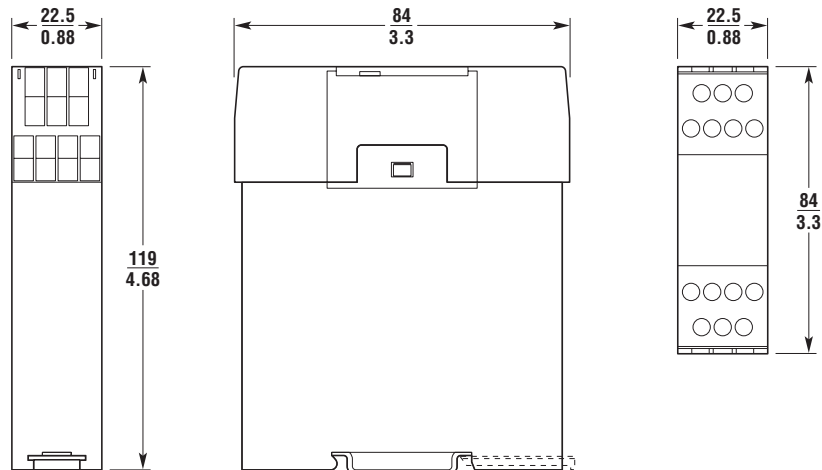

G
safety interlock switches

■ Dimensions — mm/in. (continued)

Switches

CM-S1 Switch

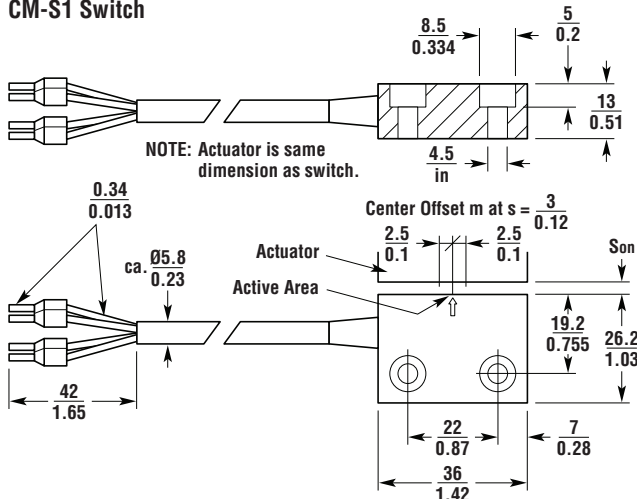

CM-S2 Switch

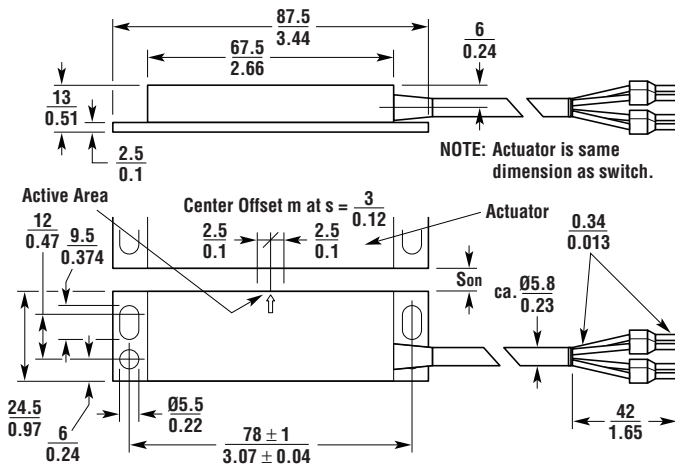

CM-S3 Switch

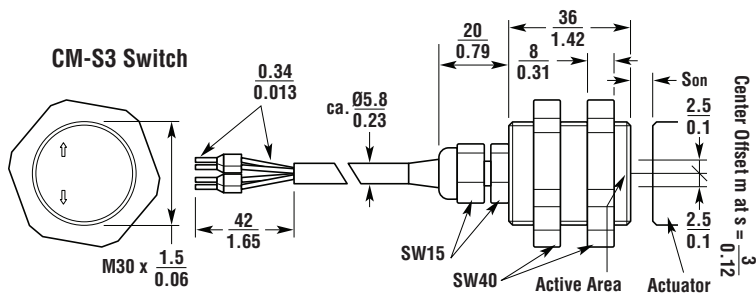

CM-S3 Actuator

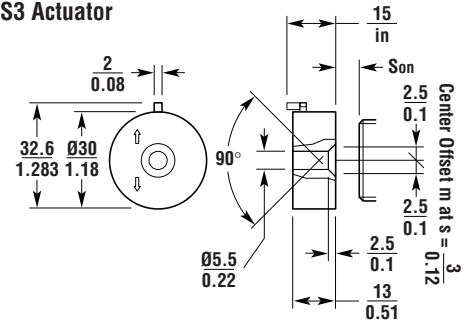

CM-S11 Switch & CM-S31 Switch

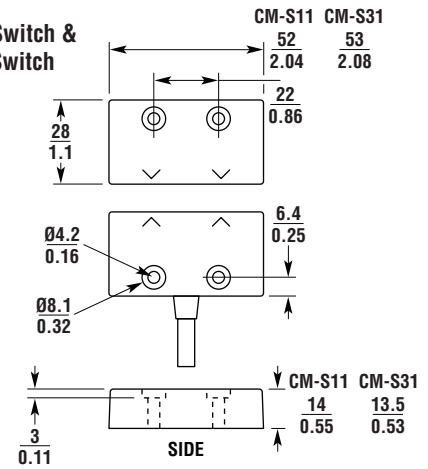

CM-S221 Switch

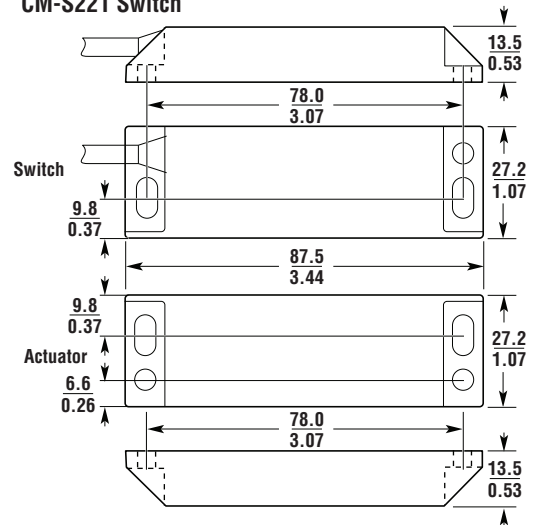

N For More Guarding Products
See Section N for safeguarding cutting and turning machines

G
safety interlock switches

■ **Ordering**

Model	Contacts	Wiring Entry	Part No.
CONTROL UNITS			
CM-S4 (24 VAC/DC) (for S1, S2, S3 Switches Only)			44536-0040
CM-S41-24 (24 VAC/DC) (for S11, S31 Solid-State Switches Only)			44536-0140
CM-S41-110 (110 VAC) (for S11, S31 Solid-State Switches Only)			44536-0141
CM-S21-24 (24 VAC/DC) (for S11, S31 Solid-State Switches Only)			44536-0120
CM-SE-24 (24 VAC/DC) (for S11, S31 Solid-State Switches Only)			44536-0170
PLASTIC CASE SWITCHES			
Model 1			
CM-S1PC3	1 N/O + 1 N/C	3 m cable	44536-0100
CM-S1PC5	1 N/O + 1 N/C	5 m cable	44536-0105
CM-S11PC3	Current Sensing Circuit	3 m cable	44536-1100
CM-S11PC5	Current Sensing Circuit	5 m cable	44536-1105
CM-S11PC10	Current Sensing Circuit	10 m cable	44536-1110
CM-S11PCC5	Current Sensing Circuit	Connector + 5 m cable	44536-1159
Model 2			
CM-S2PC3	1 N/O + 1 N/C	3 m cable	44536-0200
CM-S2PC5	1 N/O + 1 N/C	5 m cable	44536-0205
CM-S221PC5 (not compatible with Legacy Relays or SR203M/AM, SR208AD or SR209AD)	2 N/C + 1 N/O	5 m cable	44536-0221
Model 3			
CM-S3PC3	1 N/O + 1 N/C	3 m cable	44536-0300
CM-S3PC5	1 N/O + 1 N/C	5 m cable	44536-0305
STAINLESS CASE SWITCHES			
Model 1			
CM-S31SC3	Current Sensing Circuit	3 m cable	44536-3100
CM-S31SC5	Current Sensing Circuit	5 m cable	44536-3105
CM-S31SCC5	Current Sensing Circuit	Connector + 5 m cable	44536-3159
Replacement Actuator for CM-S1, Red ABS Plastic			44536-0710
Replacement Actuator for CM-S2, Red ABS Plastic			44536-0720
Replacement Actuator for CM-S221, Red ABS Plastic			44536-0721
Replacement Actuator for CM-S3, Red ABS Plastic			44536-0730
Replacement Actuator for CM-S11, Red ABS Plastic			44536-0711
Replacement Actuator for CM-S31, Stainless Steel			44536-0731
Mounting Bracket for CM-S3			44536-0800
Accessories (see page G238)			

■ = New product

 Universal Mounting Brackets can be used with this product. See page G241 for details.

G
safety interlock switches