



MOTOR DRIVE CONTROLLER



- MASTER AND FOLLOWER MODES OF OPERATION
- PROGRAMMABLE SETPOINTS:
 - TWO SPEED (Master)
 - TWO RAMP RATE (Master)
 - TWO RATIO (Follower)
 - TWO RATIO RAMP RATE (Follower)
 - ONE JOG SPEED
 - ONE JOG RAMP RATE
- 8 CHARACTER BY 2 LINE ALPHANUMERIC DISPLAY
- FOUR PROGRAMMABLE INDICATION DISPLAYS
- ON LINE SETPOINT INCREMENT/DECREMENT
- SELECTABLE DISPLAY SCROLLING
- ABILITY TO LIMIT OPERATOR ACCESS TO PROGRAMMING PARAMETERS
- ENGLISH PROGRAMMING MENUS
- FREQUENCY INPUTS ARE SWITCH SELECTABLE FOR A VARIETY OF SOURCES
- PROGRAMMABLE CONTROL INPUTS
- THREE SOLID STATE OUTPUTS
- VARIABLE SPAN (5 TO 15 VDC) ISOLATED DRIVE OUTPUT
- FEEDBACK LOSS DETECTION
- PROGRAMMABLE ALARM TYPES
- INTERNAL OR EXTERNAL DRIVE OUTPUT REFERENCE
- DIAGNOSTICS MODE
- 115/230VAC SWITCH SELECTABLE
- NON-VOLATILE MEMORY
- NEMA 4X/IP65 SEALED FRONT PANEL BEZEL

DESCRIPTION

The Motor Drive Controller (MDC) regulates motor speed by varying an isolated DC control signal to a motor drive system. There are two modes of operation, Master and Follower.

Master Mode provides control of a motor directly via programmed speed setpoints in the MDC. Regulation is maintained by a feedback frequency to the MDC taken from the motor shaft or a downstream shaft pulse encoder. Follower Mode controls a motor's speed as a ratio to a second motor's speed or outside frequency source. Ratio setpoints are programmed into the MDC causing the motor to "follow" the lead motor or frequency at a fixed speed ratio.

Master Mode has two speed setpoints and two ramp setpoints. Follower Mode has two ratio setpoints and two ramp setpoints. Both modes share a jog speed setpoint and a jog ramp setpoint. All setpoints are retained in non-volatile memory when the unit is powered down.

The Motor Drive Controller has the added feature of allowing real time adjustment of the Speed (*Master Mode*) or Ratio (*Follower Mode*) setpoint while the unit is operating a motor drive system. The setpoint may be adjusted via the front panel keypad using the "Up" or "Down" arrow keys, or via 2 User Inputs programmed for increment setpoint and decrement setpoint.

User flexibility is provided through the two-line by eight-character alphanumeric display. The display features English language menus for easy viewing and simplified programming. The four scroll-through indication displays can be programmed to show various parameters and to automatically scroll, if desired. A program disable DIP switch used with an external User Input can be utilized to protect the settings and guarantee that no unwanted changes occur during operation.

There are five dedicated control inputs on the MDC:

- RUN
- RAMP STOP
- FAST STOP
- JOG
- OPEN LOOP

There are six programmable control inputs: two front panel function keys and four remote user inputs. The F1 and F2 keys are factory programmed for RUN and R-STOP respectively. This eliminates the need for external switches in some applications.

There are three solid state outputs, two are programmable alarms and one is a dedicated Drive Enable output. Programmable alarm functions include:

- High Alarm
- Low Alarm
- Deviation Alarm
- Zero Speed
- Disabled

These may be programmed for boundary or latching operation, high or low acting.

Changing speed setpoints and programming information is easily accomplished by scrolling through menus and selecting the correct parameter. There are three main modules or menu loops:

- Display Module
- User Setpoint Module
- Programming Module

Scaling is accomplished by entering the desired values for feedback pulses per revolution (PPR), the maximum RPM, and the maximum display value.

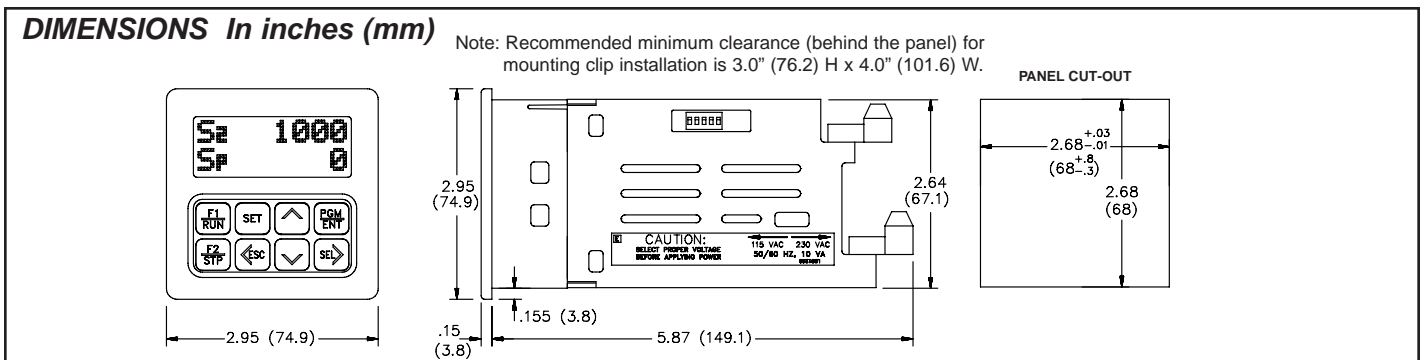

DESCRIPTION (Cont'd)

The unit is factory configured for an isolated 0 to 10 VDC drive output signal. The output drive signal can be adjusted to span from 0 to 15 VDC via an accessible potentiometer. The drive output is jumper selectable for an external reference. To use the external reference, the MDC is connected to the drive in place of an external potentiometer.

The Motor Drive Controller has a light weight, high impact plastic case with a clear viewing window. The sealed front panel meets NEMA 4X/IP65 specifications for wash-down and/or dusty environments, when properly installed. Plug-in style terminal blocks simplify installation and wiring change-outs.

SAFETY SUMMARY

All safety related regulations, local codes and instructions that appear in the manual or on equipment must be observed to ensure personal safety and to prevent damage to either the instrument or equipment connected to it. If equipment is used in a manner not specified by the manufacturer, the protection provided by the equipment may be impaired.

Do not use this unit to directly command motors, valves, or other actuators not equipped with safeguards. To do so, can be potentially harmful to persons or equipment in the event of a fault to the unit.

SPECIFICATIONS:

- DISPLAY:** 2x8, 0.3" (7 mm) high characters, negative image transmissive LCD, with red LED backlighting.
- POWER:** 115/230 VAC $\pm 10\%$, 50/60 Hz, 10 VA, switch selectable.
- MEMORY:** Non-volatile E²PROM retains all programming information and values when power is removed or interrupted.
Power Cycles(ON/OFF): 100,000 min.
Data Retention: 10 years min.
- SENSOR POWER:** +12 VDC $\pm 25\%$ @ 100 mA.
- INPUTS (LEAD AND FEEDBACK):** DIP Switch selectable to accept input pulses from a variety of sources including outputs from CMOS or TTL circuits and all standard RLC sensors.

Input Freq:

1 Hz to 20 KHz (Master Mode), 1 Hz to 12 KHz (Follower Mode).

Logic: Input trigger levels $V_{IL} = 1.5 V_{MAX}$; $V_{IH} = 3.75 V_{MIN}$.

Current Sinking: Internal 7.8 K Ω pull-up to +12 VDC, $I_{MAX} = 1.6$ mA.

Current Sourcing: Internal 3.9 K Ω pull-down, 7.3 mA @ 28 VDC_{MAX}.

Magnetic Pickup:

Sensitivity: 200 mV PEAK.

Hysteresis: 100 mV.

Input impedance: 3.9 K Ω @ 60 Hz.

Maximum input voltage: ± 50 V PEAK.

Note: For magnetic pickup input, the Sink/Source DIP switch must be in the SRC position.

- CONTROL LOOP RESPONSE:** 10 msec (Master Mode), 20 msec (Follower Mode).
- CONTROL ACCURACY:**
 0.01% of Speed Setpoint (Master Mode)
 0.02% of Ratio Setpoint (Follower Mode)
Minimum Frequency Resolution: 0.00125 Hz
- ERROR TRIM:** ± 4095 BITS.
- ERROR GAIN:** 0 to 99%.
- RAMP RATE:** (Ramp 1, Ramp 2, and Jog Ramp)
 1 Hz to 20 KHz/sec, set in user units/sec.
 0.0001 to 1.9999 ratio units/sec (Ramp 1 & 2 in Follower Mode).

CONTROL INPUTS:

Internal 10 K Ω pull-up to +5 VDC. $V_{IL} = 1.0 V_{MAX}$; $V_{IH} = 4.0 V_{MIN}$.
 Response time = 10 msec nominal, 30 msec max.

INPUTS

RUN
 FAST STOP
 RAMP STOP
 JOG
 OPEN LOOP
 USER INPUTS(4)

SWITCH CONNECTIONS

Momentary N.O.
 Momentary N.C.
 Momentary N.C.
 Sustained N.O.
 Maintained
 Function Specific

12. OUTPUTS:

Drive Enable, Alarm 1, and Alarm 2:

Solid state, current sinking NPN Open collector transistor.
 $V_{CE} = 1.1 V_{SAT}$ @ 100 mA max., $V_{OH} = 30$ VDC max.
 (Internal zener diode protection.)

Response Time:

Drive Enable: 10 msec nominal; 30 msec max.

Alarm 1&2: Programmable

Normal: 1 sec nominal, 2 sec max.

Fast: 20 msec nominal, 40 msec max.

Isolated Drive Output: Jumper selectable internal/external reference 5 mA max.

Internal Reference: Pot adjustable from 0 to 5 VDC min. through 0 to 15 VDC max. span.

External Reference: 15 VDC max. (positive polarity only).

Isolation: 2300 Vrms for 1 minute
 250 V working

13. CERTIFICATIONS AND COMPLIANCES: ELECTROMAGNETIC COMPATIBILITY

Immunity to EN 50082-2

Electrostatic discharge	EN 61000-4-2	Level 2; 4 Kv contact Level 3; 8 Kv air
Electromagnetic RF fields	EN 61000-4-3	Level 3; 10 V/m 80 MHz - 1 GHz
Fast transients (burst)	EN 61000-4-4	Level 4; 2 Kv I/O Level 3; 2 Kv power
RF conducted interference	EN 61000-4-6	Level 3; 10 V/rms 150 KHz - 80 MHz
Power frequency magnetic fields	EN 61000-4-8	Level 4; 30 A/m
Simulation of cordless telephone	ENV 50204	Level 3; 10 V/m 90 MHz ± 5 MHz 200 Hz, 50% duty cycle

Emissions to EN 50081-2

RF interference	EN 55011	Enclosure class A Power mains class A
-----------------	----------	--

Note: Refer to the EMC Installation Guidelines for additional information.

14. ENVIRONMENTAL CONDITIONS:

Operating Temperature: 0 to 50°C

Storage Temperature: -40 to 70°C

Operating and Storage Humidity: 85% max. RH (non-condensing) from 0°C to 50°C.

Altitude: Up to 2000 meters

15. CONSTRUCTION: High impact plastic case with clear viewing window. The front panel meets NEMA4 X/IP65 requirements for indoor use when properly installed. Installation Category II, Pollution Degree 2. Panel gasket and mounting clips included.

16. WEIGHT: 1.5 lbs. (0.68 Kg).

PROGRAMMING

Programming the MDC unit is accomplished through the front panel keypad, which allows the user to enter into Main Menus, Sub-Menus, and Edit Menus. The English language prompts, the flashing parameter values, and the front panel keypad aid the operator during programming. In the normal run mode, the main display loop allows the user to scroll through the four programmable indication displays, using the direction keys. From the main loop, setpoints, alarm values and a gain value may be accessed directly for changes, without entering the programming loop. All other parameters are accessed through the pro-gramming loop, which can be set to require an access code number for loop entry. In the programming loop, parameters can be viewed or changed and the operator can exit anywhere in the loop.

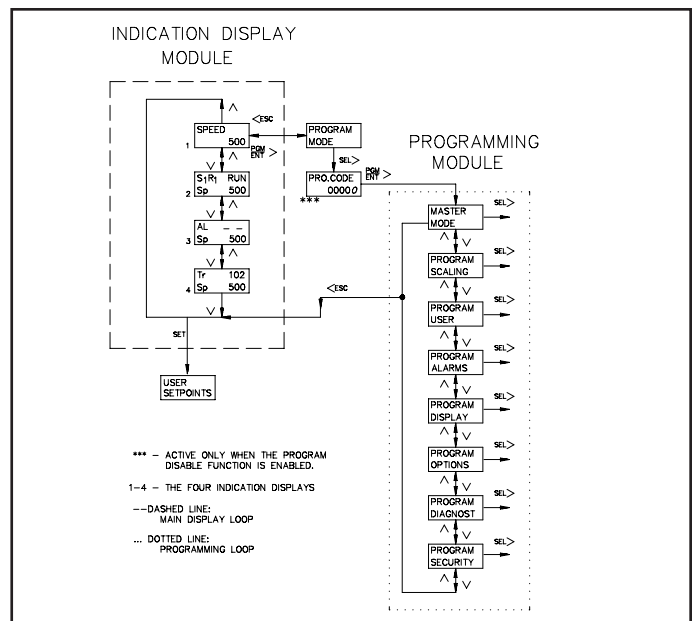
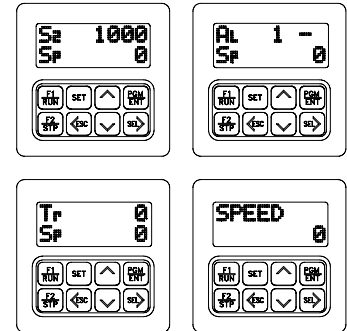

OPERATOR ACCESS

This is used with the program disable DIP switch or an external user input that is selected for the program disable function. When a setpoint is selected as NO, it can be viewed, but NOT changed from the front panel keypad. The following setpoint values can be disabled from front panel access programming:

Speed/Ratio Setpoint 1 and 2	Jog Speed
Ramp Rate 1 and 2	Jog Ramp
Alarm Setpoint 1 and 2	Gain
Setpoint Scroll Menu	

USER SETTINGS

The operator can reset ALL parameters to the factory settings if desired.

PROGRAM DIAGNOSTICS

This allows testing of the various MDC inputs and outputs. It is especially useful after unit installation to independently test the operation of external switches, relays, the feedback transducer, and the motor drive system.

Inputs - The MDC displays an alphanumeric character to indicate a Dedicated Function Input or a User Input is active. This allows the user to check switch operation and wiring connections to the Inputs.

Alarm Outputs - The up and down arrow keys are used to select an alarm output and set it to the active or inactive state. This allows the user to check the operation of devices wired to the alarm outputs and the wiring connections.

Drive Output - This function allows the user to test the Drive System. A % Output value is entered through the front panel keypad causing the motor to run at the corresponding open loop speed. The display indicates the motor's feedback frequency.

PROGRAM SECURITY

The programmable code number is used in conjunction with the program disable DIP switch and/or a user input programmed for the program disable function to limit operator access to programming.

FOLLOWER MODE APPLICATION

A fertilizer production facility is mixing pellets containing Nitrogen with pellets that contain Phosphorus. A chemical ratio of 1:1 is determined by the speed of two different conveyors. Because of differences in the gearing of the conveyor and concentration of the pellets, the Nitrogen conveyor motor must run at 3 times the speed of the Phosphorus conveyor motor in order to produce a 1:1 mixture. The maximum speed of both motors is 2000 RPM. Set the follower MDC scaling to produce a 1:1 mixture of Nitrogen and Phosphorus when a setpoint of 1.0000 is entered. Display speed units are in RPM's. Both the lead and feedback frequency are taken from 60 tooth gears on each motor shaft.

- 1) Choose the Phosphorus conveyor motor for the follower MDC. It runs slower than the Nitrogen conveyor motor.
- 2) Set the Pulses per revolution feedback to 60.
- 3) Set the MAX RPM feedback to 2000. This is the conveyor motor's maximum operating speed.
- 4) Set display decimal point to 0.
- 5) Set display unit to 2000. The display speed unit maximum is 2000 at a MAX RPM FB of 2000. If the display units wanted were conveyor feet/minute or Phosphorus pellets in lbs/sec, the equivalent display value for 2000 RPM would be entered.
- 6) Set the pulses per revolution lead to 60.
- 7) Setting the MAX RPM Lead:

This is the Lead RPM that would be necessary to have a 1:1 mixture if the Follower Speed was MAX RPM FB (2000 RPM). Since the Nitrogen conveyor motor must run 3 times as fast as the Phosphorus motor, MAX RPM LD = 3 * 2000 = 6000 RPM. Set MAX RPM LD = 6000 RPM. This is the correct value, even though the Nitrogen conveyor motor would never actually run at 6000 RPM. A ratio setpoint of 1.0000 on the MDC is now equal to a 1:1 mixture of Phosphorus and Nitrogen.

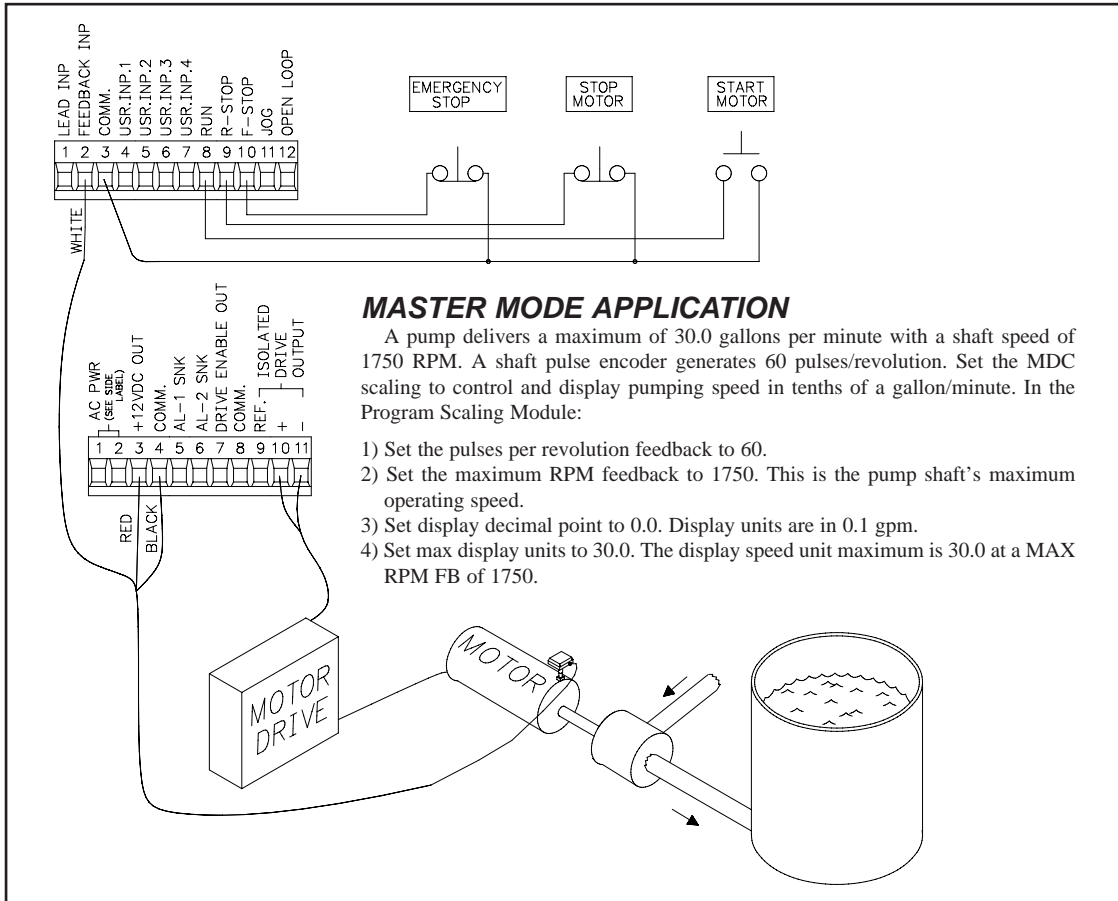

MASTER MODE APPLICATION

A pump delivers a maximum of 30.0 gallons per minute with a shaft speed of 1750 RPM. A shaft pulse encoder generates 60 pulses/revolution. Set the MDC scaling to control and display pumping speed in tenths of a gallon/minute. In the Program Scaling Module:

- 1) Set the pulses per revolution feedback to 60.
- 2) Set the maximum RPM feedback to 1750. This is the pump shaft's maximum operating speed.
- 3) Set display decimal point to 0.0. Display units are in 0.1 gpm.
- 4) Set max display units to 30.0. The display speed unit maximum is 30.0 at a MAX RPM FB of 1750.

ORDERING INFORMATION

MODEL NO.	DESCRIPTION	PART NUMBERS
MDC	Motor Drive Controller with Red Backlighting	115/230VAC MDC00100