

Notes:
 1) Case is fabricated from 1.5 mm aluminium sheet with die cast & extrusion bezels.
 2) Case is powder coat painted fine texture with RAL 7040 bezels and RAL 7035 panels.

PARTS LIST			
ITEM	QTY	PART NUMBER	DESCRIPTION
1	1	M5601002	Base Panel
2	1	M5605003	Bezel
3	1	M5602003	Rear Panel
4	4	M3 x 8 mm CSK Screw	Base Panel Screws
5	4	M3 x 8 mm Pan Screw	Rear Panel Screws
6	4	M4 x 16 mm CSK Screw	Bezel Fixing Screws
7	1	M5601053H	Top Cover
8	2	AS054231	Side Arm Kit
9	1	M5600025	Handle Bar

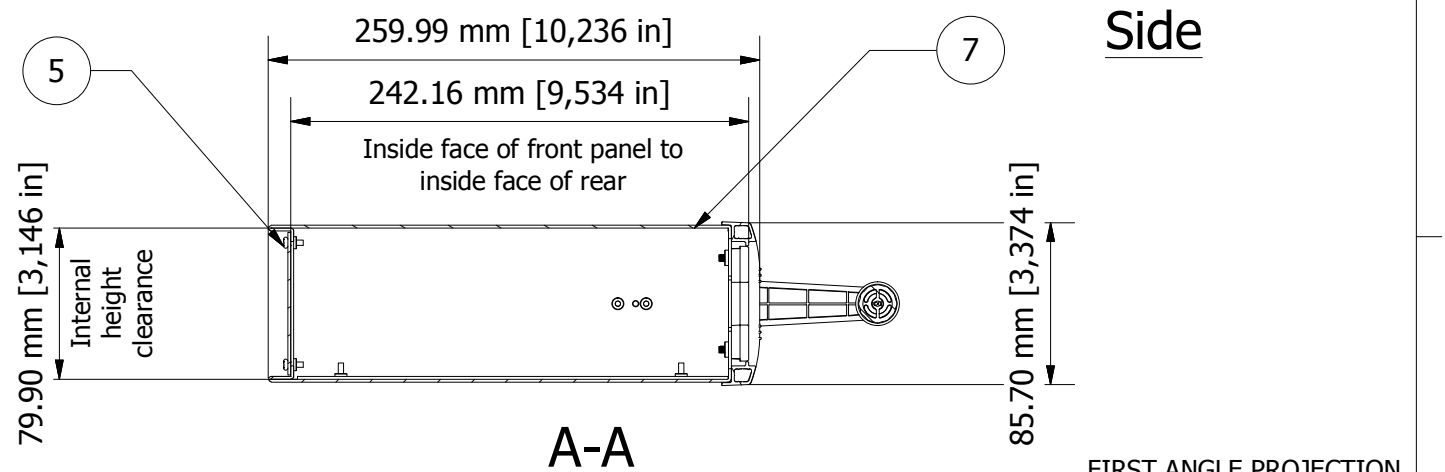
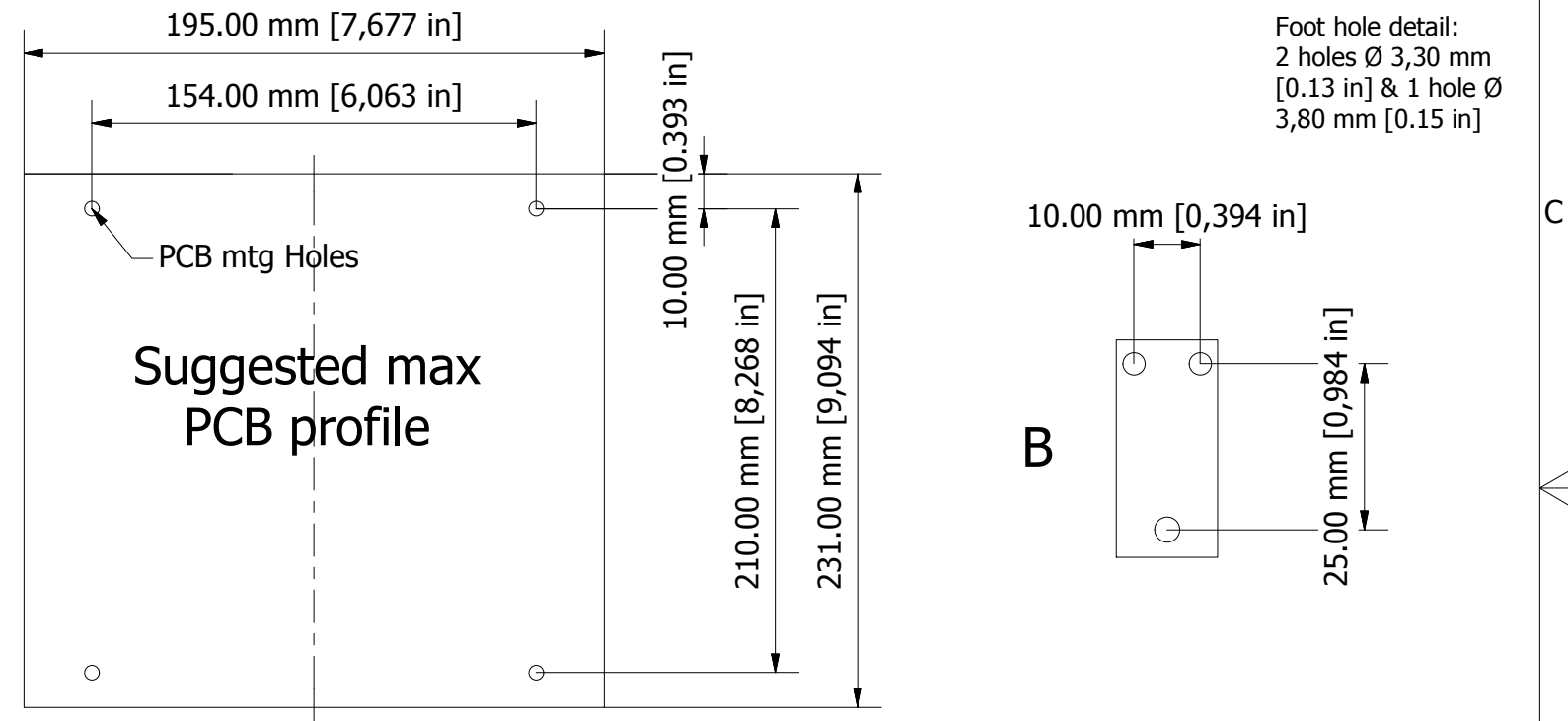

FIRST ANGLE PROJECTION

Designed by L Clark	Description Unimet 3H	Date 11/12/2012	Scale 1:4
METCASE ENCLOSURES 15 Brunel Way, Segensworth East, Fareham, Hampshire, UK. PO15 5TX Tel: +44 (0)1489 583858 Email: metcase@okw.co.uk		METcase™ www.metcase.com Part Number M5625125	
		Issue 1	Sheet 1 / 1

© OKW Enclosures Ltd (Date as shown). This drawing contains proprietary information of OKW Enclosures Ltd and is tendered subject to the following conditions. The information be retained in confidence, not be reproduced or copied, and not be used or incorporated in any product, unless permission is obtained in writing from OKW Enclosures Ltd.

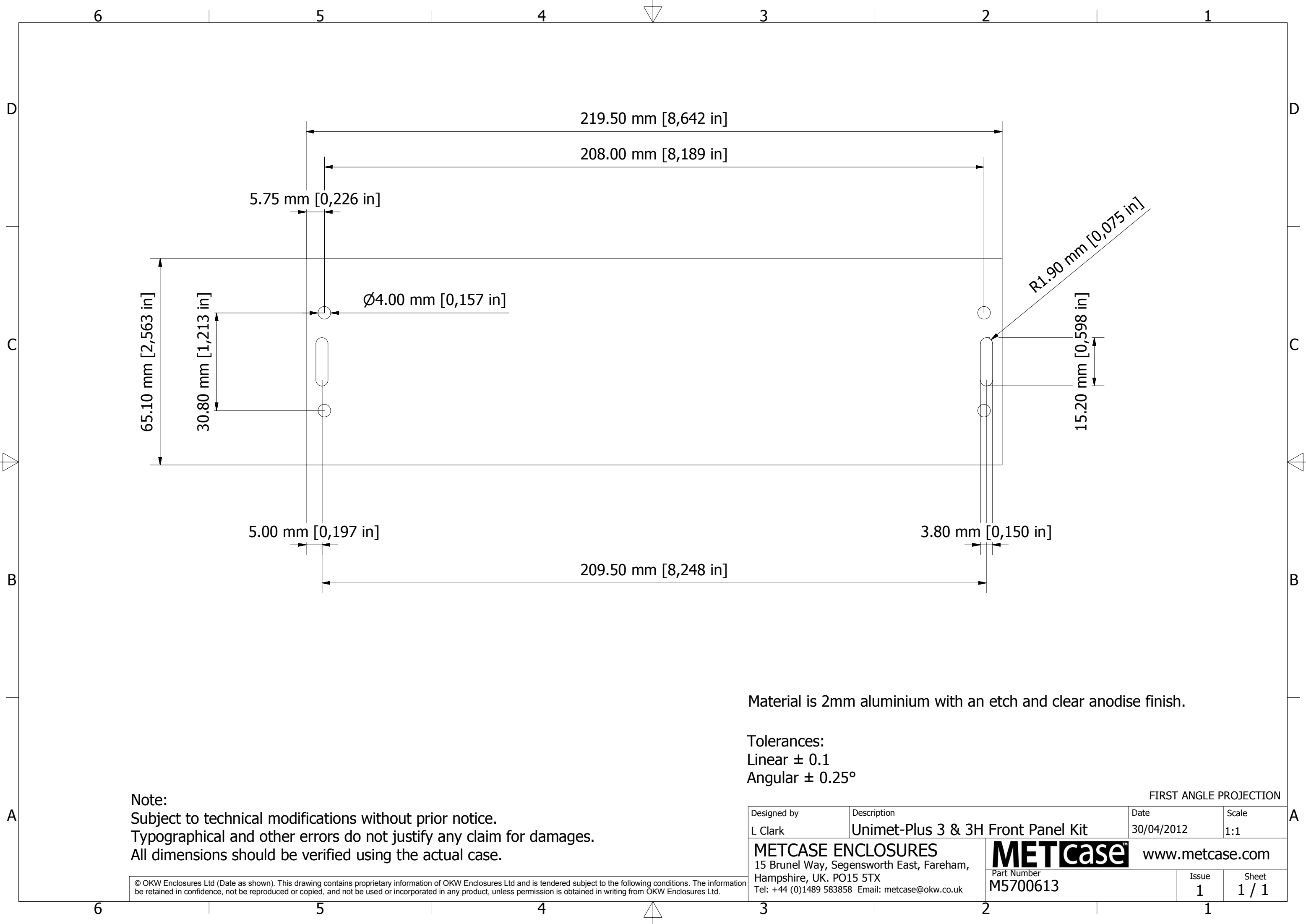

Material is 2mm aluminium with an etch and clear anodise finish.

Tolerances:
 Linear ± 0.1
 Angular $\pm 0.25^\circ$

Note:
 Subject to technical modifications without prior notice.
 Typographical and other errors do not justify any claim for damages.
 All dimensions should be verified using the actual case.

FIRST ANGLE PROJECTION

Designed by L Clark	Description Unimet-Plus 3 & 3H Front Panel Kit	Date 30/04/2012	Scale 1:1
METCASE ENCLOSURES 15 Brunel Way, Segensworth East, Fareham, Hampshire, UK. PO15 5TX Tel: +44 (0)1489 583858 Email: metcase@okw.co.uk		METcase™ www.metcase.com Part Number M5700613	
		Issue 1	Sheet 1 / 1

© OKW Enclosures Ltd (Date as shown). This drawing contains proprietary information of OKW Enclosures Ltd and is tendered subject to the following conditions. The information be retained in confidence, not be reproduced or copied, and not be used or incorporated in any product, unless permission is obtained in writing from OKW Enclosures Ltd.