

Base

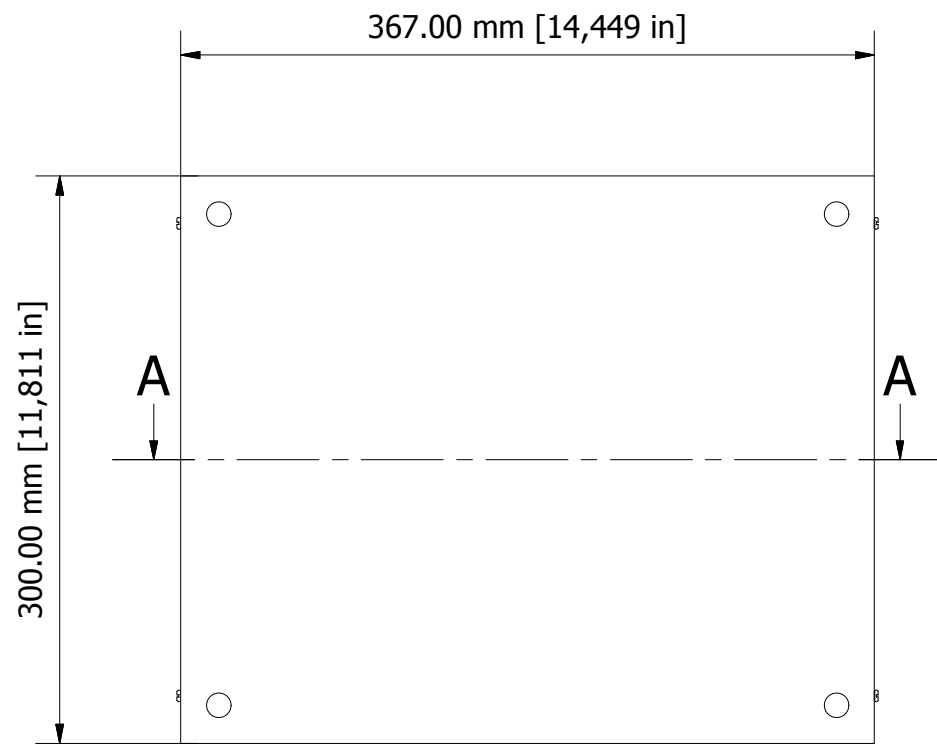

PARTS LIST			
ITEM	QTY	PART NUMBER	DESCRIPTION
3	4	M5403016	Unicase Assembly Kit
4	2	M5400004	Extrusion
5	1	M5401010	Top Cover
6	1	M5401122	Base Panel
7	2	M5402005	Front/Rear Panels

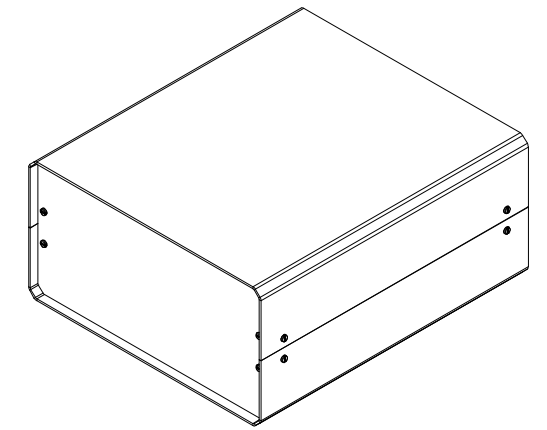
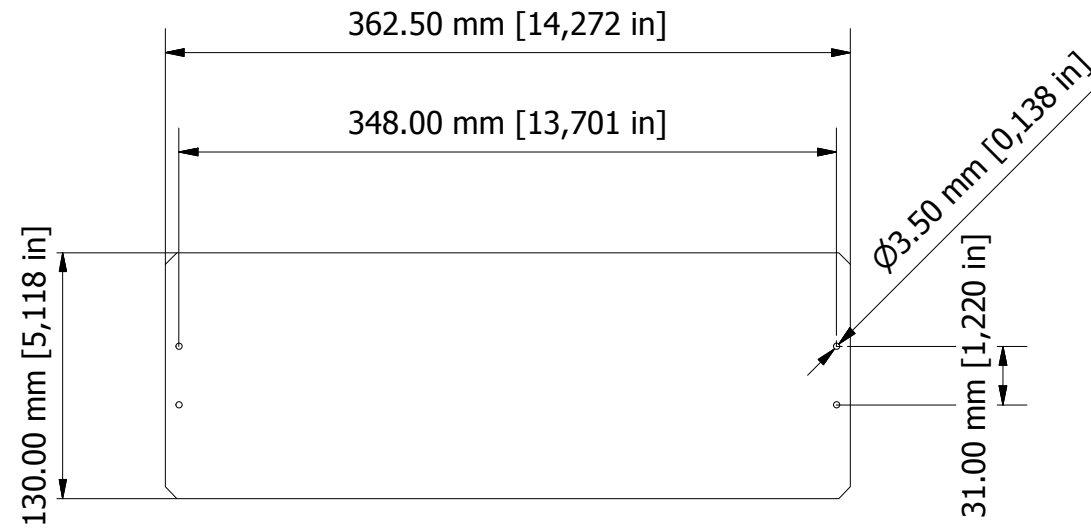

Anodised Front Panel
2 off - 2mm Thick.

Front

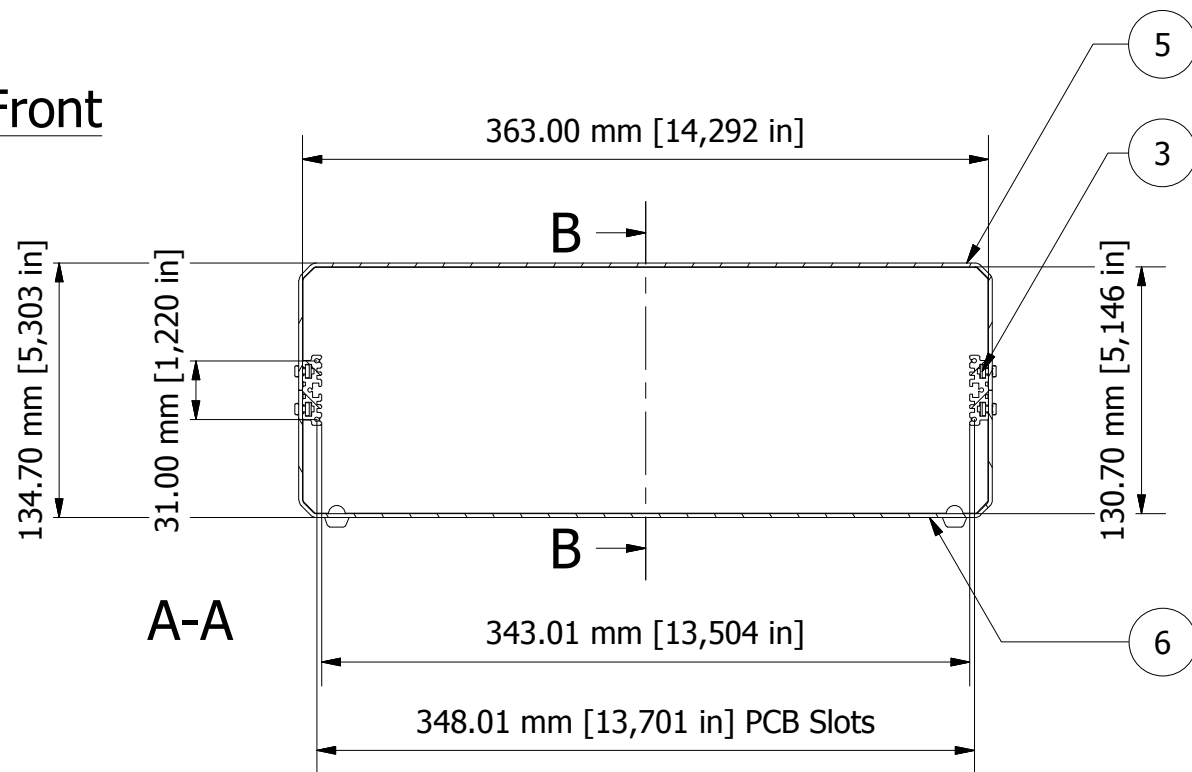

Side

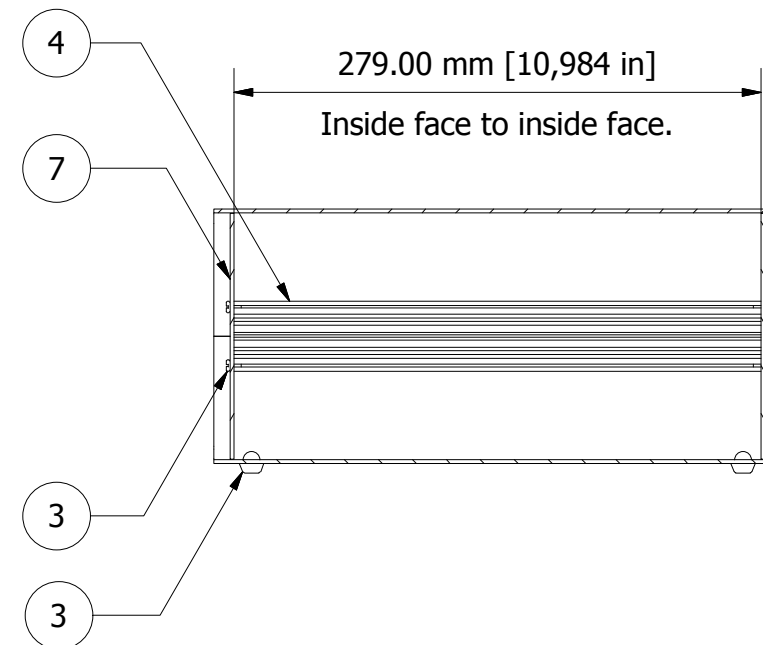

B-B

FIRST ANGLE PROJECTION

Designed by L Clark	Description UNICASE 5 LIGHT GREY	Date 02/07/2013	Scale 1:4
METCASE ENCLOSURES 15 Brunel Way, Segensworth East, Fareham, Hampshire, UK. PO15 5TX Tel: +44 (0)1489 583858 Email: metcase@okw.co.uk		METcase™ www.metcase.com Part Number M5505110	
		Issue 1	Sheet 1 / 1

© OKW Enclosures Ltd (Date as shown). This drawing contains proprietary information of OKW Enclosures Ltd and is tendered subject to the following conditions. The information be retained in confidence, not be reproduced or copied, and not be used or incorporated in any product, unless permission is obtained in writing from OKW Enclosures Ltd.