



### Main

Range of product	Harmony XVB
Accessory / separate part designation	Fixing plate for mounting on a vertical surface
Accessory / separate part type	Fixing plate
Accessory / separate part category	Mounting and fixing accessories
Product compatibility	XVBC0. XVBC11
Accessory / separate part destination	Illuminated indicator bank
Color	Black
Material	Zamak

### Complementary

Mounting support	Direct mounting on base unit On fixing base
Product weight	0.84 lb(US) (0.38 kg)

### Environment

### Contractual warranty

Warranty period	18 months
-----------------	-----------

### Dimensions and Mounting

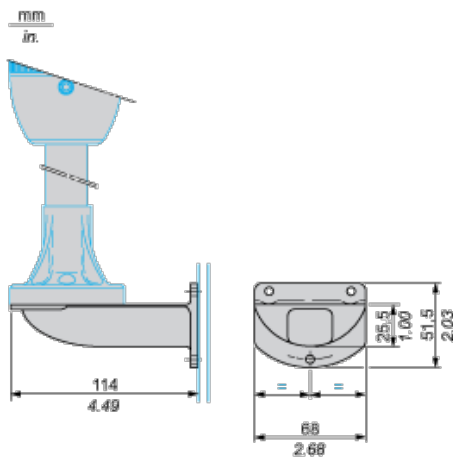

### Vertical Support Panel Drillings

The information provided in this documentation contains general descriptions and/or technical characteristics of the performance of the products contained herein. This documentation is not intended as a substitute for and is not to be used for determining suitability or reliability of these products for specific user applications. It is the duty of any such user or integrator to perform the appropriate and complete risk analysis, evaluation and testing of the products with respect to the relevant specific application or use thereof. Neither Schneider Electric Industries SAS nor any of its affiliates or subsidiaries shall be responsible or liable for misuse of the information contained herein.

