

Product Specification

NHD-C0220BA-FSW-FTW

Chip-On-Glass (COG) Liquid Crystal Display

NHD-	Newhaven Display
C0220-	COG, 2 Lines x 20 Characters
BA-	Model
F-	Transflective
SW-	Side White LED Backlight
F-	FSTN Positive
T-	12:00 Optimum View
W-	Wide Temperature

Table of Contents

Document Revision History	2
Functions and Features	2
Mechanical Drawing	3
Recommended PCB Footprint	4
Pin Description & Wiring Diagram	5
Electrical Characteristics	6
Optical Characteristics	6
Controller Information	6
DDRAM Address	6
Table of Commands	7
Timing Characteristics	8
Built-In Font Table	10
Example Initialization Program	11
Quality Information	12

Additional Resources

- **Support Forum:** <http://www.nhdforum.newhavendisplay.com>
- **Github:** <https://github.com/newhavendisplay>
- **Example Code:** https://www.newhavendisplay.com/example_code.html
- **Knowledge Center:** https://www.newhavendisplay.com/knowledge_center.html
- **Quality Center:** https://www.newhavendisplay.com/quality_center.html
- **Precautions for using LCDs/LCMs:** <https://www.newhavendisplay.com/specs/precautions.pdf>
- **Warranty / Terms & Conditions:** <https://www.newhavendisplay.com/terms.html>



Document Revision History

Revision	Date	Description	Changed By
0	3/24/21	Initial Release	AS

Functions and Features

- 2 lines x 16 characters
- Built-in ST7036 Controller
- 5.0V power supply
- 1/16 duty, 1/5 bias

Mechanical Drawing

SYMBOL	REVISION	DATE

VIEWING DIRECTION
↓

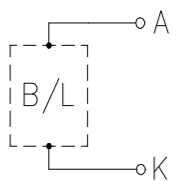
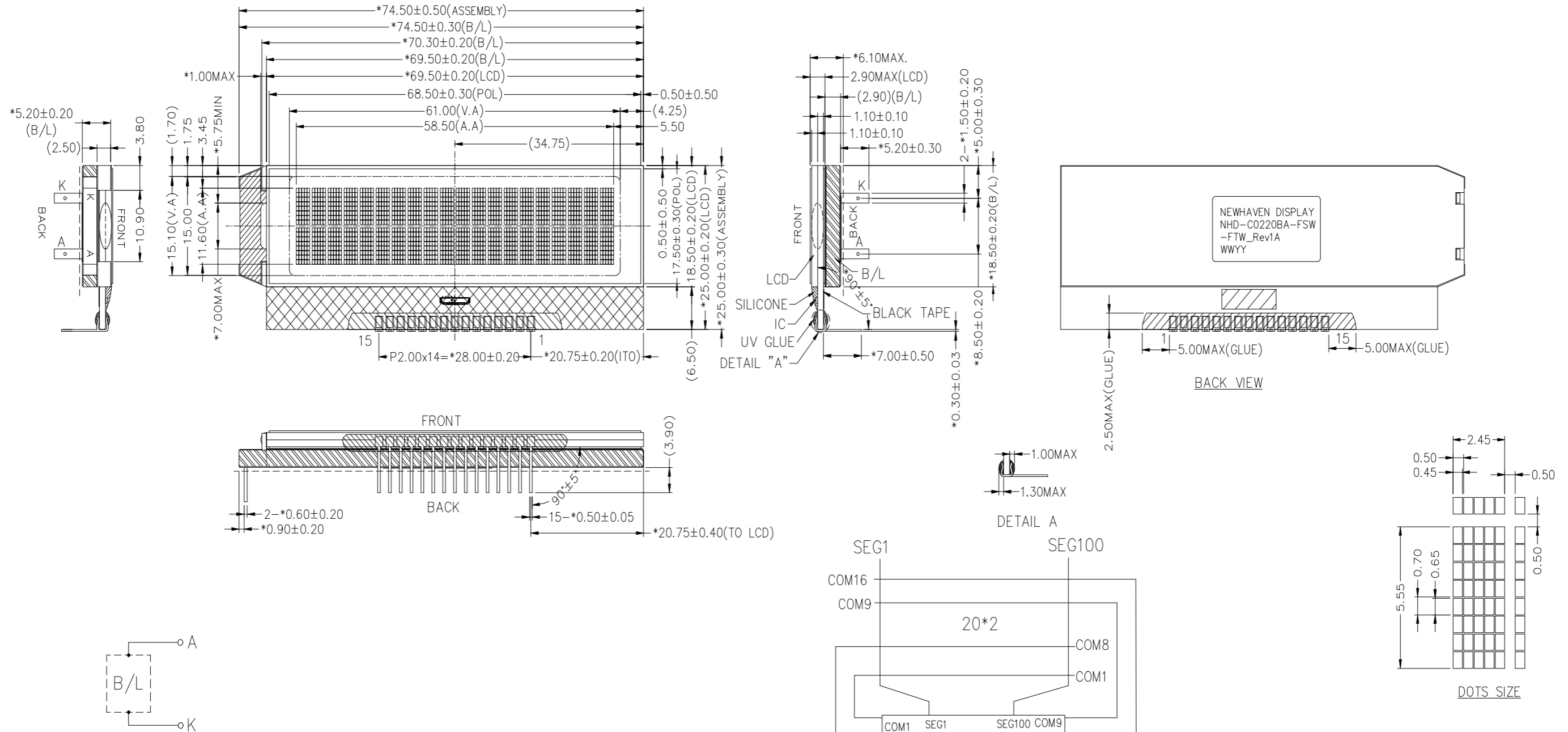

CONSTANT CURRENT: 30mA, (VF: MIN2.9V, TYP3.0V, MAX3.2V)
BACKLIGHT DRIVER CIRCUIT DIAGRAM

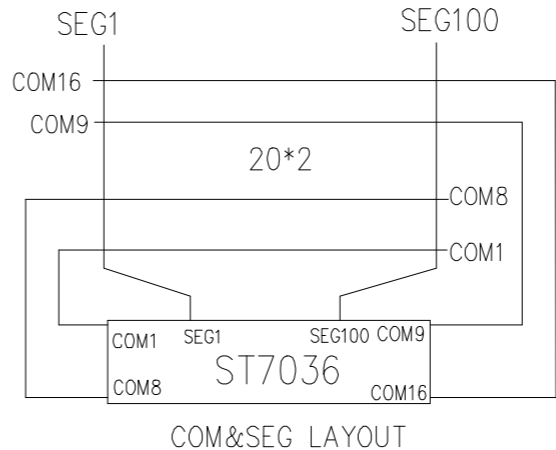

PIN	1	2	3	4	5	6	7	8
CONNECTION	RST	RS	RW	E	DB0	DB1	DB2	DB3
PIN	9	10	11	12	13	14	15	
CONNECTION	DB4	DB5	DB6	DB7	VSS	VDD	V0	

ITEM	PARAMETERS	ITEM	PARAMETERS
DISPLAY TYPE	FSTN, POSITIVE	VIEWING DIRECTION	12 O'CLOCK
DRIVING METHOD	1/16 DUTY, 1/5 BIAS	OPERATING TEMPERATURE	-20°C TO +70°C
POLARIZER TYPE	TRANSFLECTIVE	STORAGE TEMPERATURE	-30°C TO +80°C
LCD OPERATING VOLTAGE	4.4V(REF.)	IC	ST7036
LOGIC VOLTAGE(VDD)	5.0V	BACKLIGHT	EDGE, WHITE(2 LEDS)
GREYSKALE SUPPORT	NO	CONNECTOR	COG+PIN

Standard Tolerance:
(Unless otherwise specified)

Linear: ±0.3mm

Unless otherwise specified:

- Dimensions are in Millimeters
- Third Angle Projection

NEWHAVEN DISPLAY INTERNATIONAL

Drawing/Part Number: **NHD-C0220BA-FSW-FTW** Revision: **1A**

Size: **A3**

Scale: **NS**

Do Not Scale Drawing

Sheet 1 of 1



This drawing is solely the property of Newhaven Display International, Inc. The information it contains is not to be disclosed, reproduced or copied in whole or part without written approval from Newhaven Display.

Mechanical Drawing

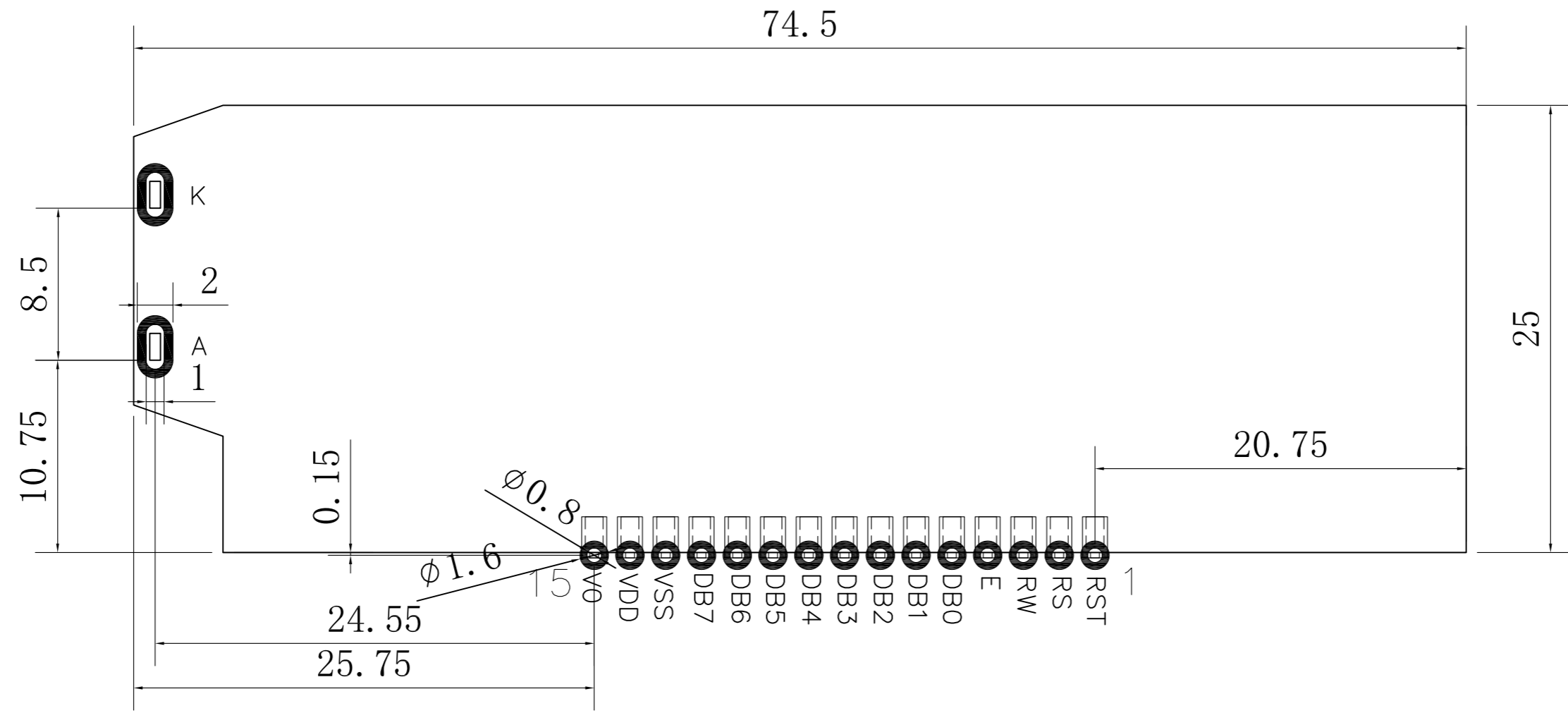
SYMBOL	REVISION	DATE



Applicable Displays:
 1) NHD-C0220BA-FSW-FTW
 2) NHD-C0220BA-FSW-FTW-3V3

Standard Tolerance: (Unless otherwise specified) Linear: ±0.3mm		
	Drawing/Part Number: NHD-C0220BA-Footprint	
Unless otherwise specified: • Dimensions are in Millimeters • Third Angle Projection 	Drawn By: A. Shah	Approved By: A. Shah
	Drawn Date: 03/24/2021	Approved Date: 03/24/2021
	Do Not Scale Drawing	
		Revision: - Size: A3 Scale: NS
Sheet 1 of 1		
This drawing is solely the property of Newhaven Display International, Inc. The information it contains is not to be disclosed, reproduced or copied in whole or part without written approval from Newhaven Display.		

Pin Description & Wiring Diagram

Pin No.	Symbol	External Connection	Function Description
1	/RST	MPU	Active LOW Reset signal
2	RS	MPU	Register Select: 0=Instruction, 1=Data
3	R/W	MPU	Read / Write select: 0=Write, 1=Read
4	E	MPU	Operation Enable Signal.
5-8	DB0 – DB3	MPU	Four low order bi-directional three-state data bus lines. These four are not used during 4-bit operation.
9-12	DB4 – DB7	MPU	Four high order bi-directional three-state data bus lines.
13	V _{SS}	Power Supply	Ground
14	V _{DD}	Power Supply	Supply Voltage for LCD and Logic (5.0V)
15	V ₀	Adj. Power Supply	Variable Supply Voltage for Contrast (approx. 0.6V)
A	LED +	Power Supply	Backlight Anode (30 mA @ 3V)
K	LED -	Power Supply	Backlight Cathode (Ground)

Recommended LCD connector: 2.0mm Pitch 15pins Soldered to PCB

Backlight connector: A and K Pins

Mates With: PCB Thru-Hole

Recommended Breakout Board: [NHD-PCB40](#)

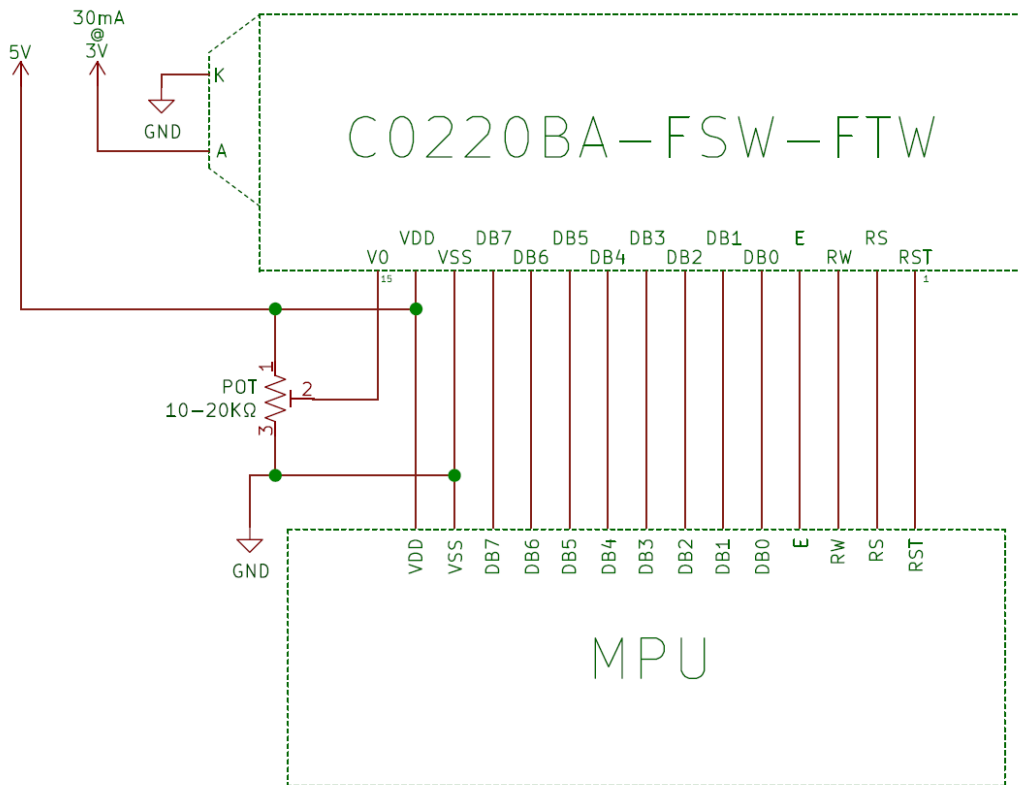

Electrical Characteristics

Item	Symbol	Condition	Min.	Typ.	Max.	Unit
Operating Temperature Range	T _{OP}	Absolute Max	-20	25	+70	°C
Storage Temperature Range	T _{ST}	Absolute Max	-30	25	+80	°C
Supply Voltage	V _{DD}	-	4.5	5.0	5.5	V
Supply Current	I _{DD}	V _{DD} = 5.0V	0.05	0.4	2.5	mA
Supply for LCD (Contrast)	V _{LCD}	T _{OP} = 25°C	4.2	4.4	4.6	V
"H" Level input	V _{IH}	-	0.7 * V _{DD}	-	V _{DD}	V
"L" Level input	V _{IL}	-	-0.3	-	0.8	V
"H" Level output	V _{OH}	-	0.7 * V _{DD}	-	V _{DD}	V
"L" Level output	V _{OL}	-	V _{SS}	-	0.8	V
Backlight Supply Current	V _{LED}	-	-	30	36	mA
Backlight Supply Voltage*	I _{LED}	I _{LED} = 30 mA	2.9	3.0	3.2	V

*The LED of the backlight is driven by current drain; drive voltage is for reference only. Drive voltage must be selected to ensure backlight current drain is below MAX level stated.

Optical Characteristics:

Item	Symbol	Condition	Min.	Typ.	Max.	Unit
Optimal Viewing Angles	Top	CR ≥ 2	-	40	-	°
	Bottom		-	40	-	°
	Left		-	35	-	°
	Right		-	35	-	°
Contrast Ratio	CR	-	2	4.5	-	-
Response Time (Rise)	T _R	T _{OP} = 25°C	-	150	-	-
Response Time (Fall)	T _F		-	100	-	-

Controller Information:

Built-in ST7036 Controller.

Please download specification at http://www.newhavendisplay.com/app_notes/ST7036.pdf

DDRAM Address:

1	2	3	4	5	6	7	8	9	10	11	12	13	14	15	16	17	18	19	20
00	01	02	03	04	05	06	07	08	09	0A	0B	0C	0D	0E	0F	10	11	12	13
40	41	42	43	44	45	46	47	48	49	4A	4B	4C	4D	4E	4F	50	51	52	53

Table of Commands

Instruction	Instruction Code										Description	Execution Time	
	RS	R/W	DB7	DB6	DB5	DB4	DB3	DB2	DB1	DB0			
Clear Display	0	0	0	0	0	0	0	0	0	0	1	Clears entire display. Does not change DDRAM address.	0.76ms
Return Home	0	0	0	0	0	0	0	0	0	1	X	Sets DDRAM Address to 0x00. Returns shifted display to original position.	0.76ms
Entry Mode Set	0	0	0	0	0	0	0	0	1	I/D	S	Sets cursor to auto Increment or Decrement, and sets display shift.	18.5us
Display ON/OFF control	0	0	0	0	0	0	0	1	D	C	B	Sets Display (D) ON/OFF. Sets Cursor (C) ON/OFF. Sets Blinking (B) of cursor ON/OFF.	18.5us
Cursor/ Display Shift	0	0	0	0	0	0	1	S/C	R/L	X	X	Moves cursor & shifts display without changing DDRAM contents.	18.5us
Function Set	0	0	0	0	1	DL	N	X	X	X	X	Set interface data length. DL = 8/4-bit Interface N = 2/1 Line Mode	18.5us
Set CGRAM address	0	0	0	1	ACG5	ACG4	ACG3	ACG2	ACG1	ACG0	ACG0	Move to CGRAM address.	18.5us
Set DDRAM address	0	0	1	ADD6	ADD5	ADD4	ADD3	ADD2	ADD1	ADD0	ADD0	Move to DDRAM address.	18.5us
Read Busy Flag & Address	0	1	BF	AC6	AC5	AC4	AC3	AC2	AC1	AC0	AC0	Read Busy Flag (BF) and Address Counter.	-
Write data to CGRAM or DDRAM	1	0	Write Data								Write data to CGRAM or DDRAM	18.5us	
Read data from CGRAM or DDRAM	1	1	Read Data								Read data from CGRAM or DDRAM	18.5us	

Timing Characteristics

Write from MPU to ST7036

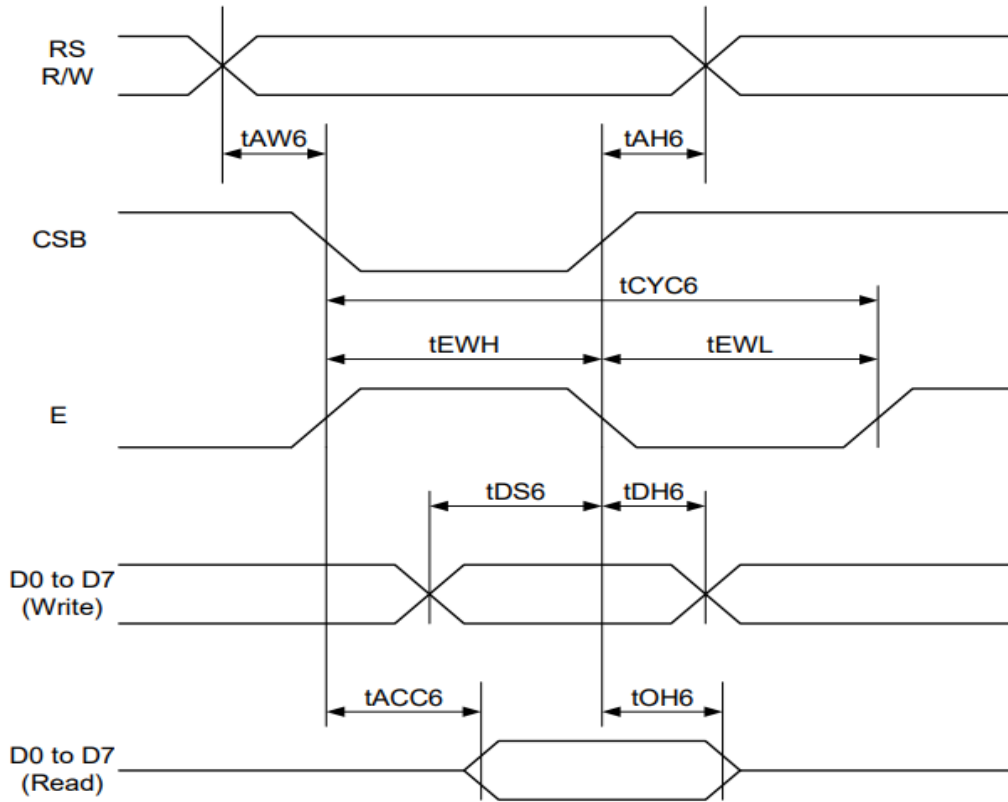

Item	Signal	Symbol	Condition	VDD=2.7 to 4.5V Rating		VDD=4.5 to 5.5V Rating		Units
				Min.	Max.	Min.	Max.	
Address hold time	RS	t _{AH6}	—	20	-	20	-	ns
Address setup time	RS	t _{AW6}		20	-	20	-	
System cycle time	RS	t _{CYC6}	—	400	-	280	-	ns
Data setup time	D0 to D7	t _{DS6}	—	100	-	80	-	ns
Data hold time	D0 to D7	t _{DH6}		40	-	20	-	
Access time	D0 to D7	t _{ACC6}	CL = 100 pF	-	500	-	400	ns
Output disable time	D0 to D7	t _{OH6}		300	-	150	-	
Enable H pulse time	E	t _{EWH}	—	200	-	120	-	ns
Enable L pulse time	E	t _{EWL}	—	150	-	130	-	ns

Read from MPU to ST7036

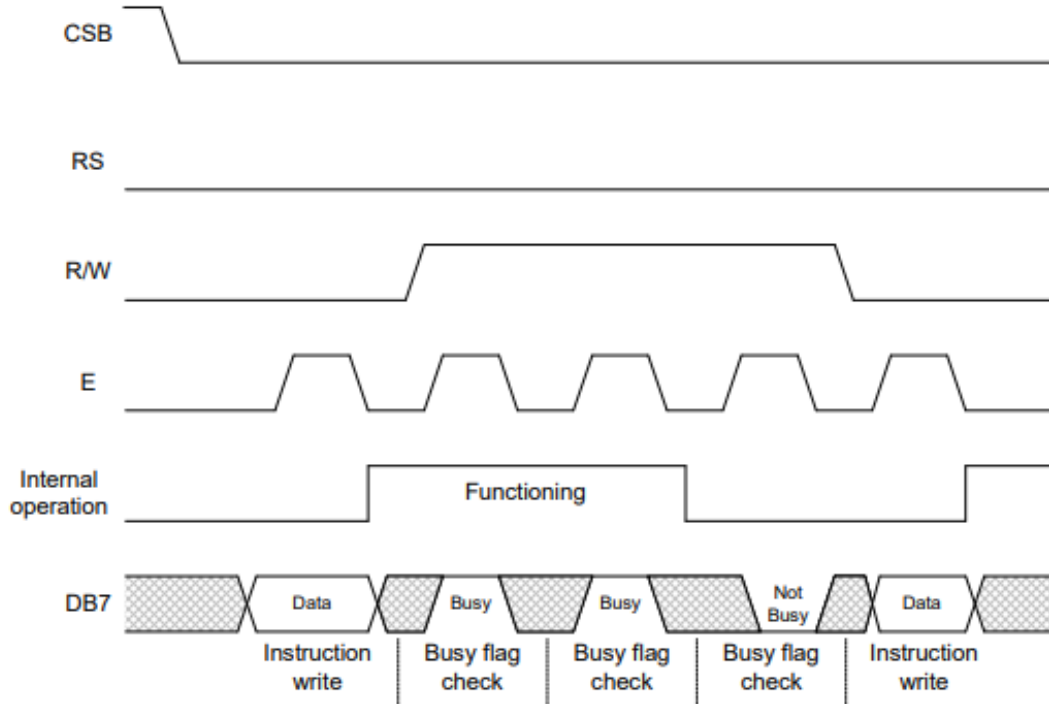

Busy Flag:

When BF = "HIGH", it indicates that the internal operation is being processed. So during this time the next instruction cannot be accepted. BF can be read when RS = "LOW" and R/W = "HIGH" (Read Instruction Operation), through DB7 Port. Before executing the next instruction, be sure that BF is not "HIGH".

RS	R/W	Operation
L	L	Instruction Write operation (MPU writes Instruction code into IR)
L	H	Read Busy Flag(DB7) and address counter (DB0 ~ DB6)
H	L	Data Write operation (MPU writes data into DR)
H	H	Data Read operation (MPU reads data from DR)

Instruction	Instruction Code										Description	Execution Time
	RS	R/W	DB7	DB6	DB5	DB4	DB3	DB2	DB1	DB0		
Read Busy Flag & Address	0	1	BF	AC6	AC5	AC4	AC3	AC2	AC1	AC0	Read Busy Flag (BF) and Address Counter.	-
Read data from CGRAM or DDRAM	1	1	Read Data							Read data from CGRAM or DDRAM	18.5us	

Built-In Font Table (OPR = 0, OPR2 = 0)

b7-b6 b5-b0	0000	0001	0010	0011	0100	0101	0110	0111	1000	1001	1010	1011	1100	1101	1110	1111
0000																
0001																
0010																
0011																
0100																
0101																
0110																
0111																
1000																
1001																
1010																
1011																
1100																
1101																
1110																
1111																

Example Initialization Program

```

/*****
*           8-bit 6800 Parallel Interface           *
*****/

void command(char i)
{
  PORTD = i;
  digitalWrite(RS, LOW);      //RS = 0
  digitalWrite(RW, LOW);     //RW = 0
  digitalWrite(E, HIGH);     // E = 1
  delay(1);                  //delay of 1 Millisecond
  digitalWrite(E, LOW);     // E = 0
  delay(1);                  //delay of 1 Millisecond
}

void data(char i)
{
  PORTD = i;
  digitalWrite(RS, HIGH);    //RS = 1
  digitalWrite(RW, LOW);    //RW = 0
  digitalWrite(E, HIGH);    // E = 1
  delay(1);                  //delay of 1 Millisecond
  digitalWrite(E, LOW);    // E = 0
  delay(1);                  //delay of 1 Millisecond
}

/*****
*           Initialization Routine           *
*****/

void init1()
{
  delay(40);      // Delay of 40 Milliseconds
  command(0x39); // Function Set
  command(0x39); // Function Set
  command(0x14); // Bias Set
  command(0x70); // Contrast Set
  command(0x5E); // Power/Icon/Contrast Control
  command(0x6A); // Follower Control
  command(0x0C); // Display On/OFF
  command(0x01); // Clear Display
  command(0x06); // Entry Mode Set
}

```

Quality Information

Test Item	Content of Test	Test Condition	Note
High Temperature storage	Endurance test applying the high storage temperature for a long time.	+80°C , 240 Hrs.	2
Low Temperature storage	Endurance test applying the low storage temperature for a long time.	-30°C , 240 Hrs.	1,2
High Temperature Operation	Endurance test applying the electric stress (voltage & current) and the high thermal stress for a long time.	+70°C , 240 Hrs.	2
Low Temperature Operation	Endurance test applying the electric stress (voltage & current) and the low thermal stress for a long time.	-20°C , 240 Hrs.	1,2
High Temperature / Humidity Storage	Endurance test applying the electric stress (voltage & current) and the high thermal with high humidity stress for a long time.	+60°C , 90% RH , 240 Hrs.	1,2
Thermal Shock resistance	Endurance test applying the electric stress (voltage & current) during a cycle of low and high thermal stress.	-30°C,30min -> 25°C,5min -> 80°C,30min = 1 cycle For 10 cycles	
Vibration test	Endurance test applying vibration to simulate transportation and use.	Frequency: 250 times/minute 1 inch distance For 45 minutes	3
Static electricity test	Endurance test applying electric static discharge.	Air Discharge= ±8kV, 5 times Contact Discharge = ±4kV, 5 times	

Note 1: No condensation to be observed.

Note 2: Conducted after 4 hours of storage at 25°C, 0%RH.

Note 3: Test performed on product itself, not inside a container.