

NEW! 881 Series

56C Parallel Shaft Gear Reducer

Key Features

- High Performance Parallel Shaft Gear Reducer
- Lighter weight, more power
- Ratios: 3.8:1 - 142.9:1
- Input Power: 1/4 - 1-1/2 HP
- Torque Rating: 32 - 1195 in-lbs
- Induction hardened helical and spur gears
- Gear efficiency 95-97%
- Mounting pattern interchanges with several popular gear reducers - Face and foot mounting options available
- Adapts to 56C motors
- Lubricated for life - sealed and gasketed
- Made in USA

The **NEW** and **IMPROVED** 881 Series parallel shaft gear reducer from Bison provides the power required for applications in a multitude of different industries. Using a newly designed precision machined die-cast aluminum housing, the 881 gear reducer can be aligned seamlessly to drive most OEM equipment. The reducer is equipped with high quality helical and spur gearing manufactured by Bison for long-lasting performance and unmatched efficiency.

The 881 series adapts to NEMA 56C motors. An optional footplate is available as an accessory for improved mounting versatility. Current drawings and stock status on the 881 series are available at bisongear.com.

The 881 series parallel shaft gear reducers are part of Bison Gear's comprehensive **In-Stock, Instant-Ship** (ISIS) program that supports Bison's distribution partners and offers same day shipment for orders received before noon (Central Time).

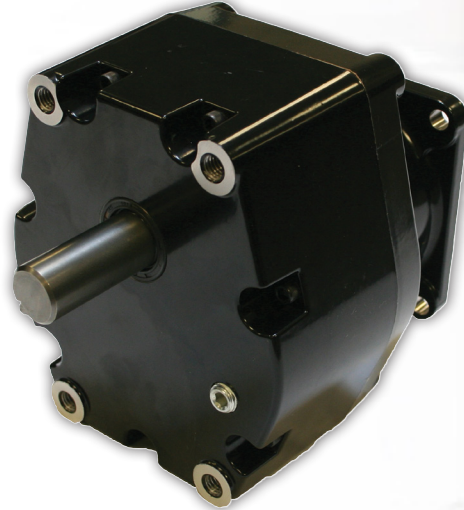

OPTIONAL FOOTPLATE ALLOWS SAME MOUNTING DIMENSIONS AS LEESON P1100 SERIES & BISON 480 SERIES GEARMOTORS

APPLICATIONS

- Conveyors
- Industrial machinery equipment
- Food processing machinery
- Waste water treatment equipment
- Pumps
- Mixers and agitators
- Chemical processing equipment
- Packaging and bottling machinery

ISIS 
In Stock Instant Ship



881 Series

56C Parallel Shaft Gear Reducer

Continuous Duty Ratings

Part Number		Ratio	Stages	Output Speed (RPM)***	Torque (in-lbs.) at listed HP						Max Torque (in-lbs)	OHL*	Shipping Wt. (lbs)
FACE MOUNT	FOOT MOUNT				1/4 HP	1/3 HP	1/2 HP	3/4 HP	1 HP	1.5 HP			
060-881-2143	060-881-2143FPM	142.9	3	12	992**						992	1383	15.6
060-881-2079	060-881-2079FPM	79	3	22	642	855	1195**				1195	1165	15.6
060-881-2053	060-881-2053FPM	53.9	3	33	438	584	876	1100**			1100	942	15.6
060-881-2041	060-881-2041FPM	41.1	3	42	334	445	668	1002			1139	858	15.6
060-881-2029	060-881-2029FPM	27.8	3	60	226	301	452	678	904		1137	838	15.6
060-881-2018	060-881-2018FPM	17.8	2	97	150	200	301	451	602	902**	902	680	15.6
060-881-2012	060-881-2012FPM	11.8	2	146	100	133	199	299	399	598	692	573	15.6
060-881-2007	060-881-2007FPM	6.8	2	253	57	77	115	172	230	345	399	506	15.6
060-881-2005	060-881-2005FPM	5.0	2	339	43	57	86	129	172	258	275	467	15.6
060-881-2004	060-881-2004FPM	3.8	2	457	32	43	64	96	128	193	204	425	15.6

* Maximum overhung load on center of output shaft
 ** Output torque is gear limited
 *** RPM based on 1725 input
 Note: Product weights do NOT include footplate.

Schematics

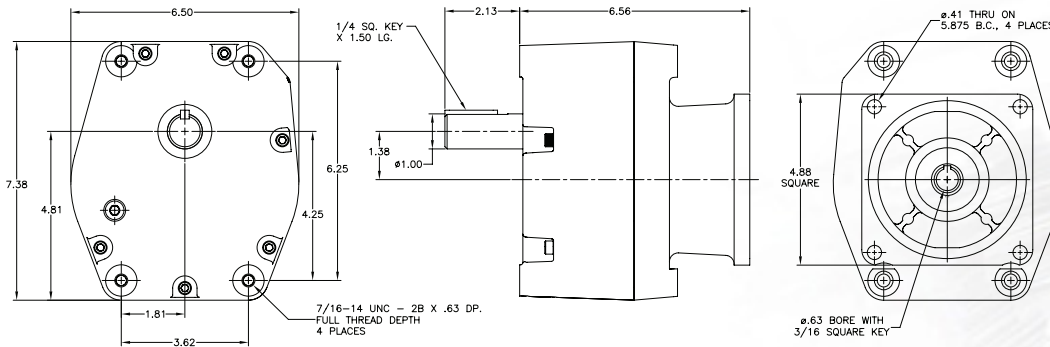

Schematics with Footplate

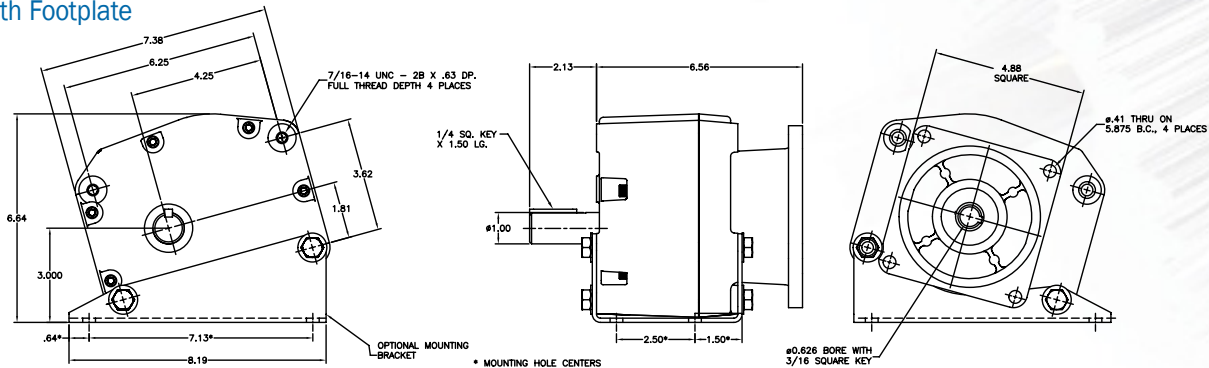

Optional Mounting Accessories

Part Number	Description
P125-880-0003	"L" Bracket
P125-880-0004	Foot plate

P125-880-0003 "L" Bracket

P125-880-0004 Foot plate

Foot plate available as stand alone item or included with FPM unit.

For questions on mounting, contact a Bison Application Engineer.

"L" Bracket Drawing

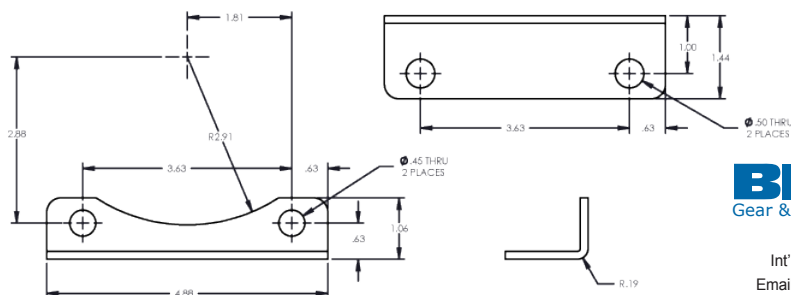

BISON
 Gear & Engineering Corp.

Ph: 800-AT-BISON

Int'l. Ph: 1.630.377.4327

Email: info@bisongear.com

www.bisongear.com