

# 80/20 Panels & Doors

## Lite Panel Mount Block

- Mounts panel flush with profile edge or on profile surface
- Panel type/thickness determines hardware to mount panel
- Spacer block can be used (pg. 4-33)
- Hardware not included

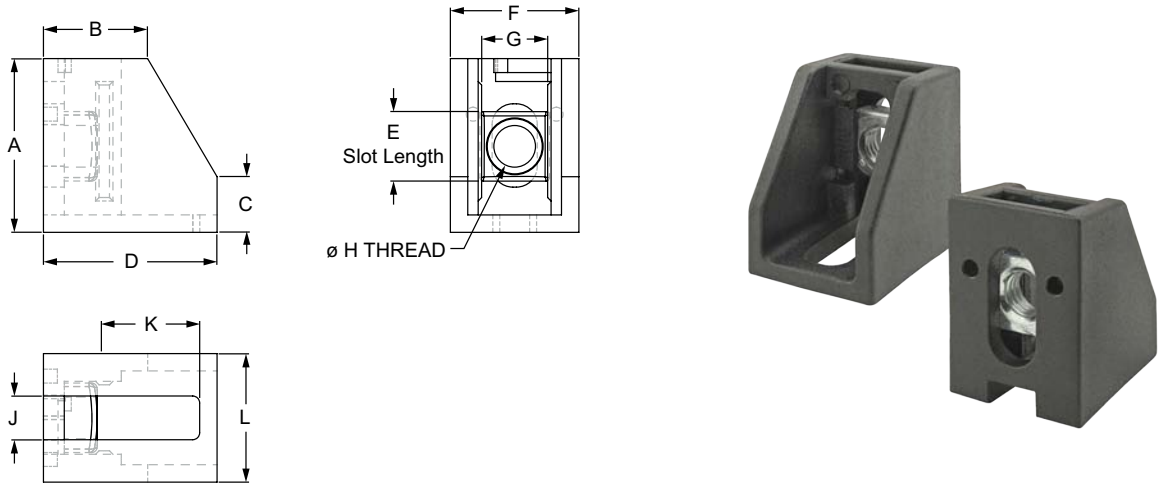

Part No.	Series	A	B	C	D	E	F	G	H	J	K	L	Weight
12050	15 30 40 45	25.00mm	15.00mm	8.00mm	25.00mm	10.00mm	18.50mm	9.50mm	M6 x 1.0	6.30mm	11.65mm	18.50mm	.0037 kg
14192		25.00mm	15.00mm	8.00mm	25.00mm	10.00mm	18.50mm	9.50mm	1/4-20	6.30mm	11.65mm	18.50mm	.0086 kg

\* This block mounted to a 30 series bar will NOT flush mount to the edge of the profile.

### Material Specifications

Material	Color	Process
Nylon	Black	Injection Molding

### Required Machining Services

Machining Type	Machined	Reference Page
Panel Mount Block Milling	Mounting Panel	10-41

### Suggested Hardware (Mount to T-Slot)

Part No.	Series	Qty.	Bolt	T-Nut
3408	15	1	1/4-20 x 1/2 BHSCS	Drop-in
75-3599	30	1	M6 x 10mm BHSCS	Drop-in
75-3600	40	1	M6 x 12mm BHSCS	Drop-in
75-3602	45	1	M6 x 14mm BHSCS	Drop-in

