

**NOTES, UNLESS OTHERWISE SPECIFIED:**

1. PARTS MUST BE RoHS COMPLIANT.
2. VISIT OUR ON-LINE CATALOG AT [WWW.PANDUIT.COM](http://WWW.PANDUIT.COM) FOR A LIST OF CURRENT PARTS APPLICABLE FOR USE WITH THIS PRODUCT.
3. PANDUIT CT-1551 TOOL.
4. WEIGHT: 27.2 oz. [ 77 ] kg.
5. CRIMPS MOST PANDUIT #22-#10 AWG INSULATED TERMINALS & SPLICES, AND SPECIFIC INSULATED DISCONNECTS.
6. REDUCED CRIMP EFFORT ADVANTAGE FOR #12-#10 AWG TERMINATIONS.
7. PROVIDES UL LISTED AND CSA CERTIFIED TERMINATIONS WITH APPLICABLE PANDUIT TERMINALS.
8. DIMENSIONS SHOWN IN BRACKETS [ ] ARE METRIC, AND ARE FOR REFERENCE ONLY.
9. NOTE DIE CHANGES TO THE LOWER LEFT. BOTH DIE SETS FUNCTION THE SAME.
10. DIE MAY EXTEND BEYOND TOOL FRAME BY .06".

CRIMP POCKET AWG/mm <sup>2</sup>	ENGLISH GO/NO GO GAGE MEMBERS		METRIC GO/NO GO GAGE MEMBERS	
	"G" Dia. (GO)	"NG" Dia. (NO GO)	"G" Dia. (GO)	"NG" Dia. (NO GO)
22-14/0,0-6,0	0.096"	0.106"	2,43 mm	2,69 mm
12-10/4,0-6,0	0.147"	0.155"	3,73 mm	3,93 mm

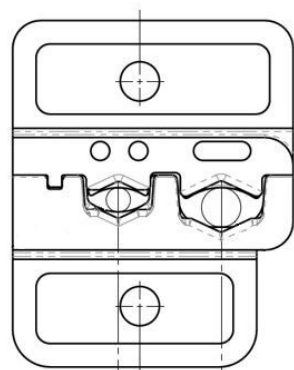

Investment Cast Die Set  
(Original)

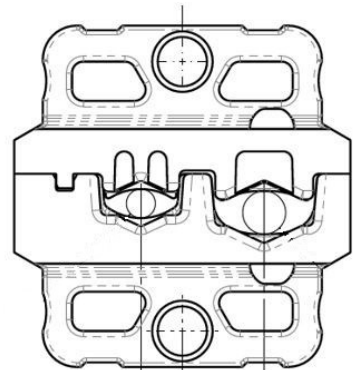

Metal Injection Molded  
Die Set, MIM (New)

REV	DATE	BY	CHK	APR	DESCRIPTION	ECN
02A	7-28-2020	JEH	BJPU	BJPU	ADDED NOTE 10	080205/01
02	6-3-2020	JEH	BJPU	JADE	RECREATED THE CUST. DWG. IN NX. WAS A MS WORD DRAWING. ADDED DIE CHANGE NOTE 9 AND VIEWS (LOWER LEFT CORNER).	080905

TITLE <b>CT-1551 Contour Crimp Crimping Tool</b>			
CUSTOMER DRAWING			
ITEM REVISION NAME R27603BA/02		<b>PANDUIT</b>	
DATASET FILE NAME R27603BA/02A_DS_TP27603B01			
THIRD ANGLE PROJECTION		DRAWING NUMBER <b>TP27603B01</b>	
MATERIAL	-		
DRAWN BY BLR	DATE 5-11-15	CHK BJPU	SCALE NONE
SHEET 1 OF 1			SIZE <b>B</b>