

Economy Lift-Off Hinge Right Hand with Short Pin

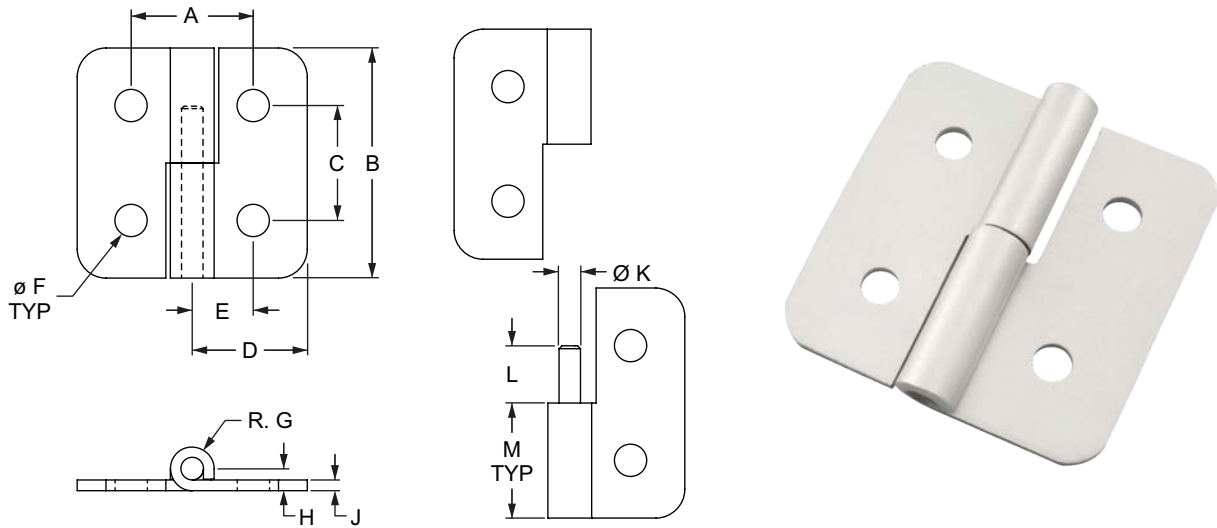

Part No.	Series	Max Load	A	B	C	D	E	F	G	H	J	K	L	M	Weight
2837	10	40 lb	1.062"	2.000"	1.000"	1.000"	.531"	.281"	.191"	.191"	.093"	.187"	.500"	1.000"	.045 lb
2839	15	70 lb	1.620"	3.000"	1.500"	1.500"	.812"	.328"	.250"	.250"	.120"	.250"	.750"	1.500"	.134 lb
25-2837	25	18 kg	26.97mm	50.80mm	25.40mm	25.40mm	13.48mm	7.13mm	4.85mm	4.85mm	2.36mm	4.75mm	12.70mm	25.40mm	.0200 kg
40-2839	40	32 kg	41.15mm	76.20mm	38.10mm	38.10mm	20.62mm	8.30mm	6.35mm	6.35mm	3.05mm	6.35mm	19.05mm	50.80mm	.2758 kg

\*The gap distance between profiles for 10 series is .062", 15 series is .120", 25 series is 1.97mm, 40 series is 1.15mm.

Material Specifications

Material	Alloy	Finish	Process
Aluminum	5052-H32 = Leaf 6061-T6 = Pin	Clear Anodize	Milled

Suggested Hardware (Mount to T-Slot)

Part No.	Series	Qty.	Bolt	T-Nut
3386	10	4	1/4-20 x 3/8 FBHSCS	Economy
3319	15	4	5/16-18 x 1/2 FBHSCS	Economy
75-3404	25	4	M6 x 10mm BHSCS	Economy
75-3421	40	4	M8 x 12mm BHSCS	Economy

