

REVISIONS			
REV.	DESCRIPTION	DATE	APPROVED
A	REDRAWN IN SW	2/24/2006	BEM

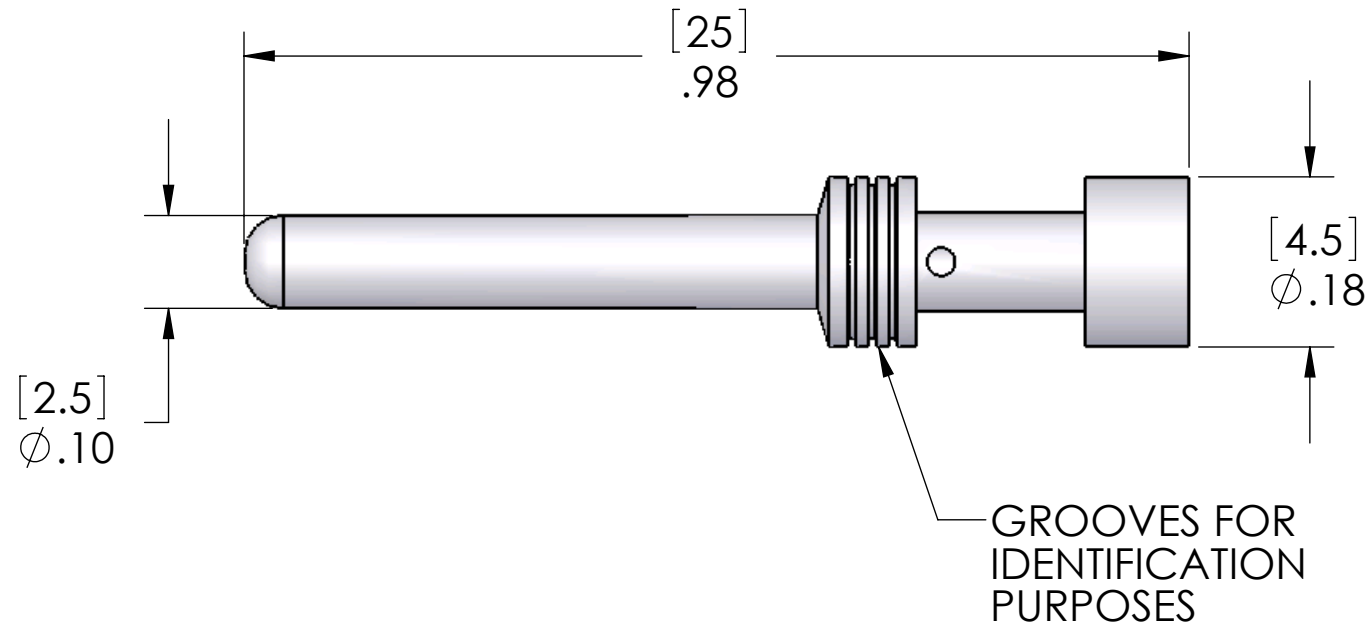

PART NUMBER	WIRE AVG	WIRE HOLE DIAM	SQ. MM	# OF GROOVES
CCMA-0.5	20	0.043 [1.1]	0.5	0
CCMA-1.0	18	0.057 [1.45]	1.0	1
CCMA-1.5	16	0.071 [1.8]	1.5	2
CCMA-2.5	14	0.087 [2.2]	2.5	3
CCMA-4.0	12	0.112 [2.85]	4.0	0

SUGGESTED WIRE STRIP: 0.30 [7.5]

SUGGESTED CRIMP TOOL:
CCPZ-MIL w/ CCTP-16 LOCATOR

SUGGESTED REMOVAL TOOL:
CQES

MATERIALS	
BODY:	SILVER PLATED COPPER ALLOY

PROPRIETARY AND CONFIDENTIAL
THE INFORMATION CONTAINED IN THIS DRAWING IS THE SOLE PROPERTY OF MENCOM CORPORATION. ANY REPRODUCTION IN PART OR AS A WHOLE WITHOUT THE WRITTEN PERMISSION OF MENCOM CORPORATION IS PROHIBITED.

UNLESS OTHERWISE SPECIFIED:
DIMENSIONS ARE IN INCHES AND [MM]
MATERIAL
FINISH
DO NOT SCALE DRAWING

NAME
DRAWN BEM
CHECKED
ENG APPR.
MFG APPR.
Q.A.
COMMENTS:

MENCOM CORPORATION
TITLE:
SIZE DWG. NO. REV
B CCMA-X.X **A**
SCALE: 5:1 WEIGHT: SHEET 1 OF 1