

THIS COPY IS PROVIDED ON A RESTRICTED BASIS AND IS NOT TO BE USED IN ANY WAY DETRIMENTAL TO THE INTERESTS OF PANDUIT CORP.

PART NUMBER	SEE DETAIL	"A" +/- .062	MARKER ACROSS	TUBING COLOR	SEE STYLE	MARKERS PER ROLL
H050X064H1T	A	0.50 [12.70]	4	WHITE	A	2000
H100X064H1T	B	1.00 [25.40]	2			1000
H200X064H1T	C	2.00 [50.80]	1			500
H050X064H2T	A	0.50 [12.70]	4	YELLOW	A	2000
H100X064H2T	B	1.00 [25.40]	2			1000
H200X064H2T	C	2.00 [50.80]	1			500
H050X064H3T	A	0.50 [12.70]	4	BLACK	A	2000
H100X064H3T	B	1.00 [25.40]	2			1000
H200X064H3T	C	2.00 [50.80]	1			500
H050X064H4T	A	0.50 [12.70]	4	RED	A	2000
H100X064H4T	B	1.00 [25.40]	2			1000
H200X064H4T	C	2.00 [50.80]	1			500
H050X064H1T-B	A	0.50 [12.70]	4	WHITE	B	2000
H100X064H1T-B	B	1.00 [25.40]	2			1000
H200X064H1T-B	C	2.00 [50.80]	1			500

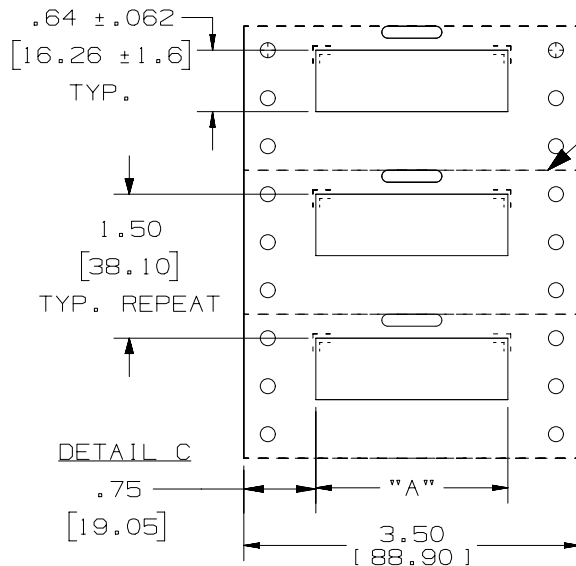

10

10

10

PERFORATION

NOTES:
1. DIMENSIONS IN [] ARE IN MILLIMETERS.

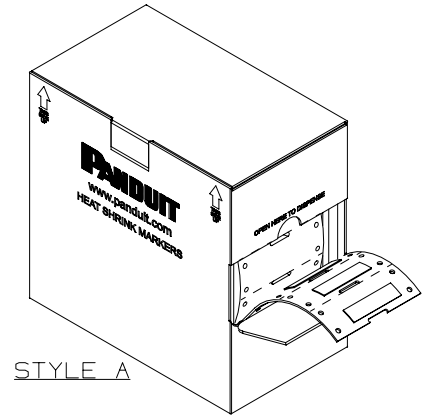
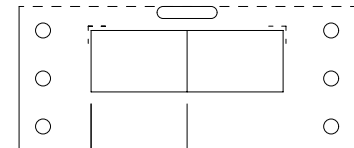
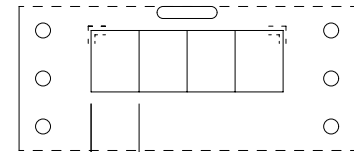

STYLE A

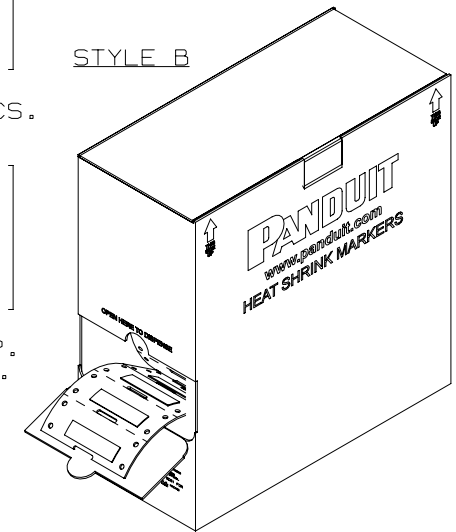

STYLE B

REV	DATE	BY	CHK	APR	DESCRIPTION	ECN
10	4/29/15	RVU	SEWH	JHAC	ADD NEW COLUMN OF MARKERS PER ROLL. 0.75 [19.05] REF. WAS "B".	GAECN02783
9	1/20/15	RVU	SEWH	MSAD	REVISE OLD LOGO TO CURRENT PANDUIT LOGO.	GAECN02542
8	4/12/12	RVU			REVISED ON DETAIL A, B, C DESIGN TO SHOW ALL MARKERS.	6731
7	11/29/10	RVU			CHANGE BOXES DESIGN.	6230
6	5/21/09	RVU			+/- .12, +/- .062, +/- .020 WAS +/- .03, +/- .032, +/- .020. HT: .64 +/- .062 WAS .640. MAT'L, HSK TUBING GMUHS31, 3.5 WIDE LINER WAS GMUHS. ADD "A" +/- .062. ADD STYLE B VIEW FOR BULK BOX. VIEWS UPDATE.	5593

TITLE		H***x064H** OPTIMUM COMPUTER PRINTABLE MIL. SPEC. HEAT SHRINK MARKERS CUSTOMER DRAWING	
ITEM REVISION NAME		I00923NI/12	
DATASET FILE NAME		I00923NI_DC_C10435/12L	
UNLESS OTHERWISE SPECIFIED, DIMENSIONAL TOLERANCES ARE: IN [mm]		MATERIAL:	
.x ± .12 [3.05] .xxx ± .020 [0.508]		HEATSHRINK TUBING GMUHS31, 3.5 WIDE LINER	
.xx ± .062 [1.57] ANGLES ±		DRAWING NUMBER:	
THIRD ANGLE PROJECTION		C10435	
DRAWN BY	DATE	CHK	SCALE
RVU	8/2/06	MSAD	NTS
SHT 1 OF 1			SIZE A