

D  
C  
B  
A

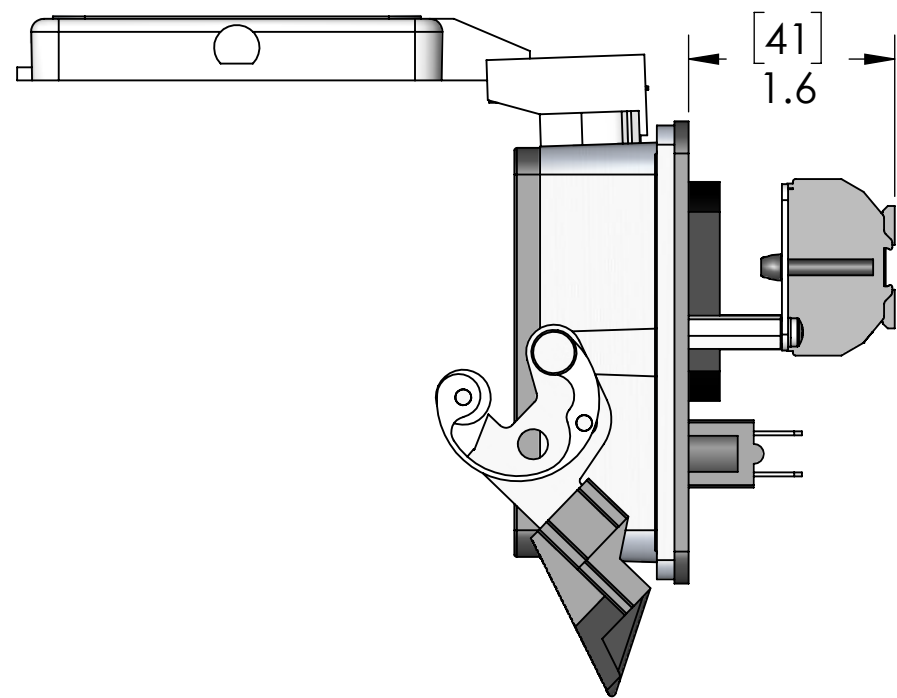

PANEL CUTOUT

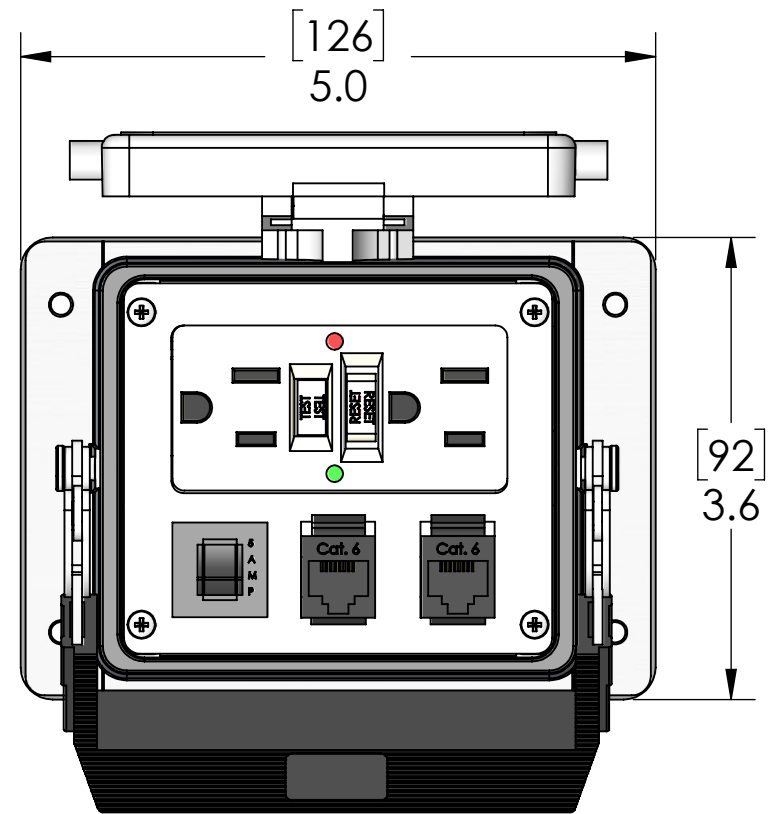
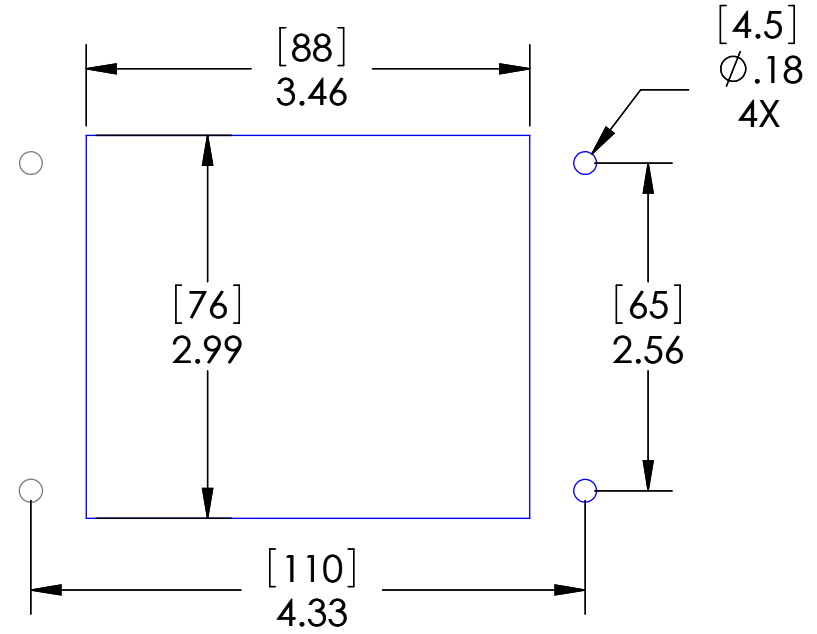

These devices shall be mounted on enclosures having adequate strength and thickness and with adequate spacing provided. Seal rating is based on mounting to a surface that is clean, flat and smooth.

HOUSING MATERIALS	
BODY:	EPOXY COATED DIE CAST ALUMINUM
GASKET:	THERMOPLASTIC ELASTOMER
HANDLE:	POLYAMIDE
LEVERS:	STAINLESS STEEL

PIC RATINGS/SPECIFICATIONS	
VOLTS:	125V
AMPS:	5A
SCCR:	0.2kA
NEMA/UL   EN 60529:	4, 4X, 12   IP65
MOUNTING SCREW SIZE:	M4 (8-32) (304 or 316SS for 4X)
MOUNTING SCREW TORQUE:	1.2~1.8N-m (0.9~1.3 Lb-Ft)
INCOMING POWER WIRE SIZE:	0.5 ~ 4.0 sq mm / 20-12AWG
WIRE STRIP LENGTH:	10 ~ 11 mm

OPERATING TEMPERATURE: (-10°C / +60° C (14° F / +140° F))

MOUNTING KIT ORDERED SEPARATELY CONTAINS M4x0.7 SS SCREW, NYLON WASHER, SPLIT LOCKWASHER AND M4 NUT  
**P/N: D-PIC-MT**



UNLESS OTHERWISE SPECIFIED:

DIMENSIONS ARE IN INCHES AND [MM]
MATERIAL
FINISH
DO NOT SCALE DRAWING

DRAWN BY	GO
DRAWN DATE	05/20/2021
CHECKED BY	JJH
CHECK DATE	05/21/2021

**MENCOM CORPORATION**

TITLE: GF; 2RJ45; 5A; 32

SIZE <b>B</b>	DWG. NO. GF-2RJ45-5R-32	REV <b>B</b>
SCALE: 2:3	WEIGHT:	SHEET 1 OF 1

STANDARD CONFIGURATIONS UNLESS OTHERWISE NOTED		
CONN. TYPE	EXTERIOR	INTERIOR
RJ45	CAT. 6 JACK	CAT. 6 JACK