

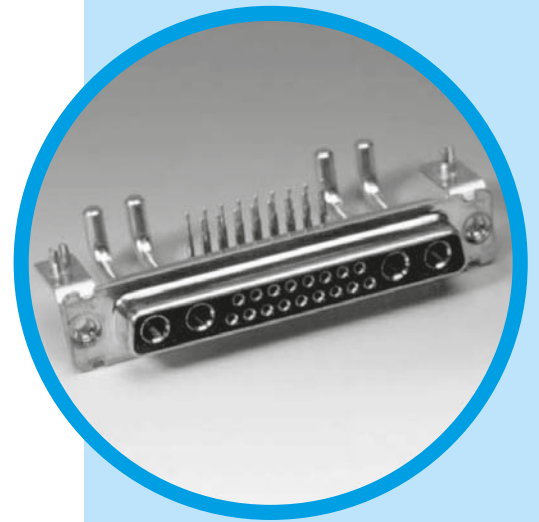

TW

Hybrid D'Sub series



MAIN CHARACTERISTICS

Specifications

- Connectors according to: MIL C24308 - NFC93425 - HE507

Materials and plating		Electrical Data	
Shells	Steel-Tin plating	Current rating	
Insulators	High temperature black thermoplastic	Signal contacts	7.5 A. with 10 A. peak
Signal contacts	Female: machined bronze	Power contacts	
Material	Male: machined brass	PCB terminations	10 to 40 A.
Plating finish	Flash, 15µ" Au over 79µ" Ni min. or 30µ" Au over 79µ" Ni min.	Solder cup terminations	10 to 40 A.
Shielded contacts	Female: machined bronze	Crimp terminations	10 to 40 A.
Material	Male: machined brass	Shielded contacts	0.5 A.
Plating		Voltage rating	
Inner conductor	15µ" Au or 30µ" Au over 79µ" Ni	Signal and power contacts	300 V.R.M.S. at 50 Hz
Outer ring	Flash Au over 79µ" Ni	Shielded contacts	150 V.R.M.S. at 50 Hz
Terminations	Tinned	Shielded contacts	
Except solder cup and crimp terminations	30µ" Au	Frequency range	0-1 GHz
Power contacts	Female: machined bronze	Attenuation	0.2dB
Material	Male: machined brass	V. S. W. R.	1.4(+0.04/GHz)
Plating		Characteristic impedance	50 Ohms
Contacts	Flash, 15µ" Au or 30µ" Au over 79µ" Ni	Dielectric withstanding voltage	≥ 1000 V.R.M.S. at 50Hz
Terminations	Tinned	Insulation resistance	≥ 5000 M Ohms at 500 VDC
Except solder cup and crimp terminations	15µ" Au	Contact resistance	≤ 5m Ohms
Brackets	Steel-Tin plating	Shell resistance (electrical grounding)	≤ 1m Ohm
Front jackscrews	Brass-Tin plating		
Rear clinch nuts	Brass-Tin plating		
Boardlocks	Bronze-Tin plating		
Stand-off	Brass-Tin plating		

Climatic Data		Mechanical data	
Operating temperature	-55°C +155°C (with peak of 180°C)	Shells	With or without dimples
Damp heat	56 days (40°C -95% RH)	Contact retention force in dielectric material	> 40N
Salt spray	48 hours	Maximum mating and unmating force	
		With dimples	E size = 70 N A size = 80 N B size = 100 N C size = 150 N D size = 180 N
		Without dimples	E size = 30 N A size = 50 N B size = 80 N C size = 120 N D size = 160 N
		Compatible with process	
		IR - Air convection	260°C for 20s.
		Resistance to solder iron heat	260°C for 30s.
		Mating cycles	100 (class III) 200 (class II) 500 (class I)



DESCRIPTION

Amphenol D'Sub TW Hybrid Series permits a mix of contacts including signal, power, shielded and high voltage in the same housing with different contact arrangements.

This economic series was first developed from our military series, and has improved features:

- new contacts
- new high temperature black thermoplastic insert
- PCB configurations come preloaded with fixed contacts and brackets.

These connectors are supplied with screw machined contacts fixed in the insulator.

A complete range of housings are also available for cable application.

*Full series
multiple
arrangement
connectors*

APPLICATIONS

- Commercial
- Medical
- Industrial
- Telecom
- Any application requiring optimization of space

TW / E1





















Amphenol

Shell and contact plating

CLASS 3 Flash Gold Signal & Power		CLASS 2 .4um(15u") Signal, Power, Coax		CLASS 1 .76um(30u") Signal, Power Coax	
Type	Shell + Plating	Type	Shell + Plating	Type	Shell + Plating
76	Tin plated shell Pin or Socket	77	Tin plated shell Pin or Socket	177	Tin plated shell Pin or Socket
716	Tin plated shell with grounding dimples-Pin only	717	Tin plated shell with grounding dimples-Pin only	777	Tin plated shell with grounding dimples-Pin only

Housing arrangement

Male front view

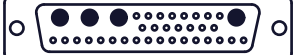
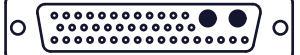
Arrangement... Shell size.....	 2W2 E	 P2W2 E	 P3W3 E
Arrangement... Shell size.....	 5W1 A	 7W2 A	 11W1 A
Arrangement... Shell size.....	 3W3 A	 5W5 B	 9W4 B
Arrangement... Shell size.....	 13W3 B	 17w2 B	 21W1 B
Arrangement... Shell size.....	 27W2 C	 13W6 C	 17W5 C
Arrangement... Shell size.....	 21WA4 C	 8W8 C	 25W3 C
Arrangement... Shell size.....	 24W7 D	 36W4 D	 43W2 D

Shell size dimensions

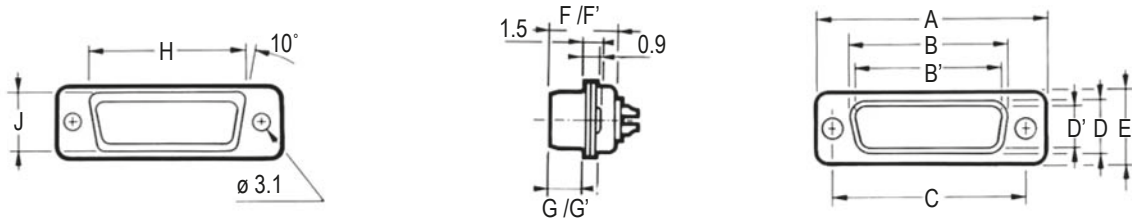

Shell size	Contact P: Pin S: Socket	A ±0.25 (±.010)	B 0/-0.20 (0/-0.008)	B' +0.20/0 (+.008/0)	C ±0.10 (±.004)	D 0/-0.25 (0/-0.010)	D' +0.25/0 (+.010/0)	E ±0.20 (±.008)	F +0.05/-0.20 (+.002/-0.008)	F' +0.10/-0.20 (+.004/-0.008)	G +0.10/-0.20 (+.004/-0.008)	G' ±0.10 (±.004)	H +0.10/-0.40 (+.004/-0.016)	J 0/-0.50 (0/-0.020)
E	P	30.7 (1.209")		16.8 (.661")	25.0 (.984")		8.2 (.323")	12.4 (.488")		10.9 (.429")		5.9 (.232")	19.4 (.764")	11.0 (.433")
	S		16.4 (.646")			8.0 (.315")			11.1 (.437")		6.2 (.244")			
A	P	39.0 (1.535")		25.1 (.988")	33.3 (1.311")		8.2 (.323")	12.4 (.488")		10.9 (.429")		5.9 (.232")	27.7 (1.091")	11.0 (.433")
	S		24.8 (.976")			8.0 (.315")			11.1 (.437")		6.2 (.244")			
B	P	52.9 (2.083")		38.8 (1.528")	47.0 (1.850")		8.2 (.323")	12.4 (.488")		11.0 (.433")		5.8 (.228")	41.4 (1.630")	11.0 (.433")
	S		38.5 (1.513")			8.0 (.315")			11.1 (.437")		6.2 (.244")			
C	P	69.2 (2.724")		55.3 (2.177")	63.5 (2.500")		8.2 (.323")	12.4 (.488")		11.0 (.433")		5.8 (.228")	57.9 (2.280")	11.0 (.433")
	S		54.9 (2.161")			8.0 (.315")			11.1 (.437")		6.2 (.244")			
D	P	66.8 (2.630")		52.7 (2.075")	61.1 (2.406")		11.0 (.433")	15.2 (.598")		11.0 (.433")		5.8 (.228")	55.5 (2.185")	13.8 (.543")
	S		52.5 (2.067")			10.9 (.429")			11.1 (.437")		6.2 (.244")			

Panel cutouts

Optimal cutout for rear mounting

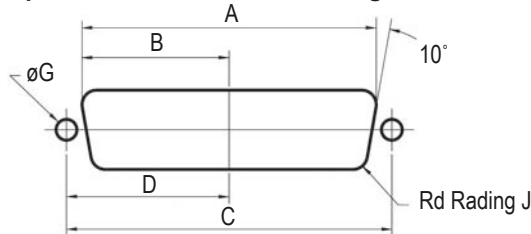

Standard cutout

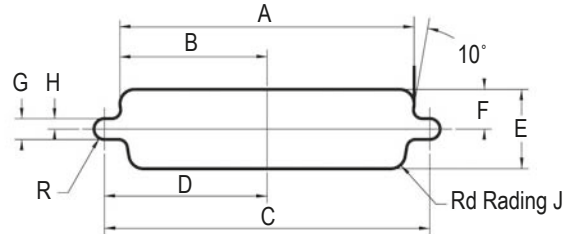

Shell size	Mounting method	A ±0.20 (±.008)	B ±0.20 (±.008)	C ±0.20 (±.008)	D ±0.20 (±.008)	E ±0.20 (±.008)	F ±0.20 (±.008)	G ±0.20 (±.008)	H ±0.20 (±.008)	J ±0.20 (±.008)
E	Front	22.2 (.874")	11.1 (.437")	25.0 (.984")	12.5 (.492")	13.0 (.512")	6.5 (.256")	3.0 (.118")	1.5 (.059")	2.1 (.083")
	Rear	20.5 (.807")	10.2 (.402")							
A	Front	30.5 (1.201")	15.3 (.602")	33.3 (1.311")	16.7 (.657")	13.0 (.512")	6.5 (.256")	3.0 (.118")	1.5 (.059")	2.1 (.083")
	Rear	28.8 (1.134")	14.4 (.567")							
B	Front	44.3 (1.744")	22.1 (.870")	47.0 (1.850")	23.5 (.925")	13.0 (.512")	6.5 (.256")	3.0 (.118")	1.5 (.059")	2.1 (.083")
	Rear	42.5 (1.673")	21.3 (.839")							
C	Front	60.7 (2.390")	30.4 (1.197")	63.5 (2.500")	31.7 (1.248")	13.0 (.512")	6.5 (.256")	3.0 (.118")	1.5 (.059")	2.1 (.083")
	Rear	59.1 (2.327")	29.5 (1.161")							
D	Front	58.3 (2.295")	29.2 (1.150")	61.1 (2.406")	30.6 (1.205")	15.8 (.622")	7.9 (.311")	3.0 (.118")	1.5 (.059")	2.1 (.083")
	Rear	56.3 (2.217")	28.2 (1.110")							

Straight connector footprint

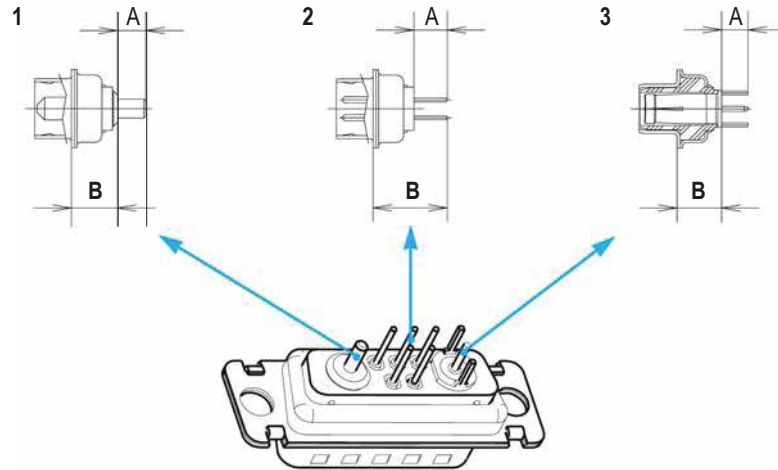

Signal tail 0.6 mm Dia. (.024")
 1.6 mm (.063")PCB
 For other PCB thickness: consult factory.

Description		Dimensions	
		a	b
Power 3.2mm(.126") tail dia	1	4.80 mm (.189")	7.2 mm (.283")
Power 2.0mm(.078") tail dia	1	4.80 mm (.189")	7.2 mm (.283")
Shielded	3	4.00 mm (.157")	7.2 mm (.283")
Signal	2	5.30 mm (.209")	11.50 mm (.453")

Straight contact combinations

Arrangement with signal contacts

See above dimensions	Size 8 and 20 Contacts
↓	
P 3SY	Power 3.2 mm DIA. (.126") (20 to 40 A) and signal
P 2SY	Power 2 mm DIA. (.078") (10 to 20 A) and signal
CSY	Shielded and signal
SY	Signal only
No reference	Signal (Size 20) with solder cup terminations <i>Housing preloaded with contacts</i>

Arrangement without signal contacts 2W2 - 3W3 - 5W5 - 8W8

See above dimensions	Size 8 Contacts
↓	
P 3Y	Power only 3.2 mm DIA. (.126") (20 to 40 A)
P 2Y	Power only 2 mm DIA. (.078") (10 to 20 A)
CY	Shielded only

Right angle connector footprint

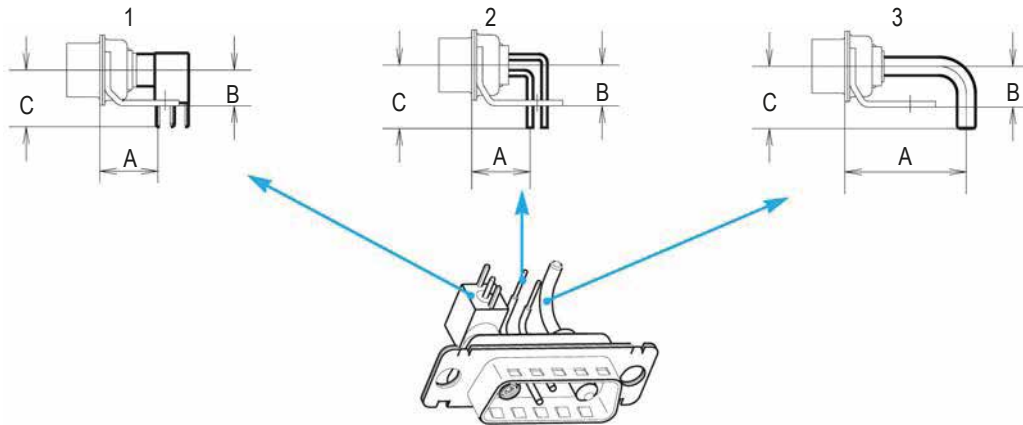

Signal tail 0.6 mm Dia. (.0236")
 1.6 mm (.063") PCB
 For other PCB thickness: consult factory.

Description	Europe			Mix			MIL		
	a	b	c	a	b	c	a	b	c
Shielded 1	-	-	-	10.30mm (.406")	6.30mm (.248")	10.00mm (.394")	10.30mm (.406")	6.30mm (.248")	10.00mm (.394")
Signal 2	10.30mm (.406")	7.20mm (.283")	11.20mm (.441")	10.30mm (.406")	6.30mm (.248")	9.50mm (.374")	8.10mm (.319")	6.30mm (.248")	9.50mm (.374")
Power 2.0mm(.078") tail dia 3	11.57mm (.456")	7.20mm (.283")	10.50mm (.413")	11.57mm (.456")	6.30mm (.248")	9.50mm (.374")	9.52mm (.375")	6.30mm (.248")	9.50mm (.374")
Power 3.2mm(.126") tail dia 3	21.46mm (.845")	7.20mm (.283")	10.50mm (.413")	21.46mm (.845")	6.30mm (.248")	9.50mm (.374")	21.46mm (.845")	6.30mm (.248")	9.50mm (.374")

Note: above dimensions correspond to sizes E to C. Consult factory for D sizes.
 Connector comes equipped with contacts and brackets.

Right angle contacts combinations

Arrangement with signal contacts

European footprint	Mixed footprint	MIL (U.S.) footprint	Size 8 and 20 Contacts
EP3SV	HP3SV	MP3SV	Power 3.2 mm DIA. (.126") (20 to 40 A) and signal
EP2SV	HP2SV	MP2SV	Power 2 mm DIA. (.078") (10 to 20 A) and signal
-	HCSV	MCSV	Shielded and signal
ESV	HSV	MSV	Signal only

Arrangement without signal contacts 2W2 - 3W3 - 5W5 - 8W8

European footprint	Mixed footprint	MIL (U.S.) footprint	Size 8 contacts only
EP3V	HP3V	MP3V	Power only 3.2 mm DIA. (.126") (20 to 40 A)
EP2V	HP2V	MP2V	Power only 2.0 mm DIA. (.078") (10 to 20 A)
-	HCV	MCV	Shielded only

Mounting options

Right angle version

Connectors come equipped with metal brackets

BLANK: Metal brackets

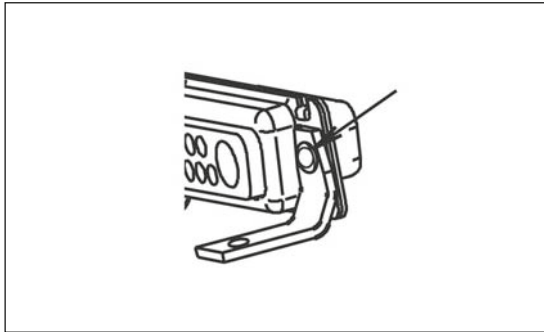

RM6: Metal brackets + boardlock

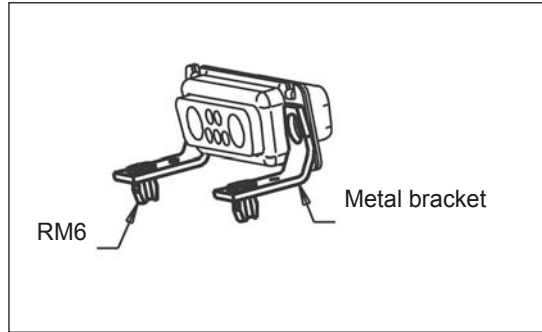

Straight version

BLANK: 3.10mm (.122") dia mounting hole

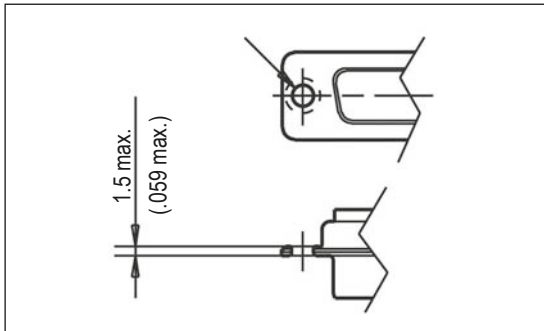

RM54: 4-40 threaded standoff and B/L
RM53: M3 threaded standoff and B/L

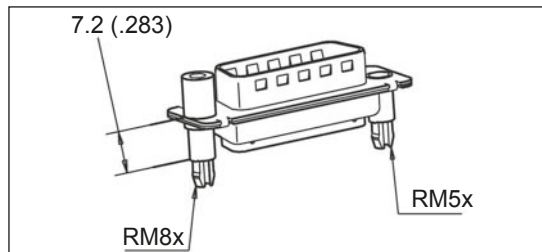

RM84: 4-40 fixed screwlocks+RM54 (combo)
RM83: M3 removable screwlocks + RM53

A514: blind mating system

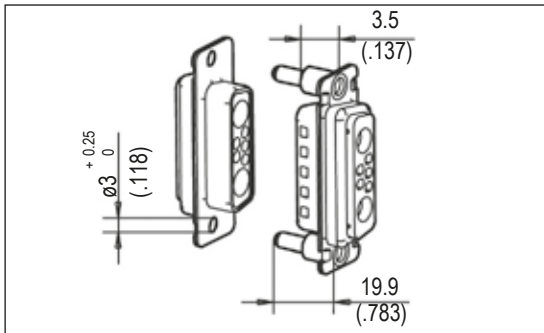

FM: float mounting system

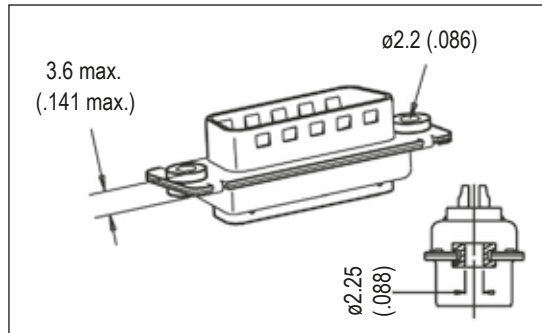

Straight and right angle version

4R: 4-40 rear nut
3R: M3 rear nut

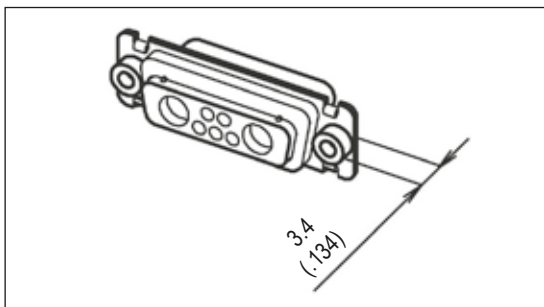

4F: 4-40 fixed front female screwlock
3F: M3 fixed front female screwlock

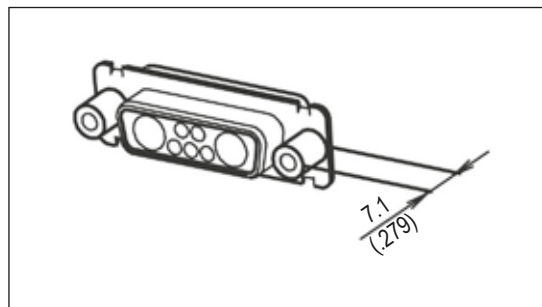

High power contacts

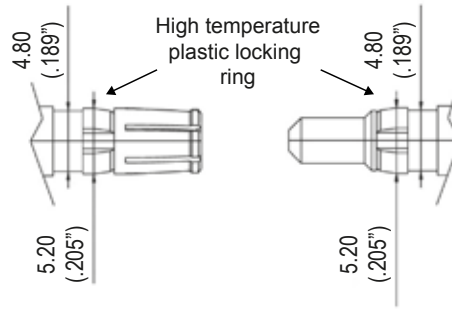

Solder cup version

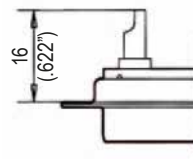
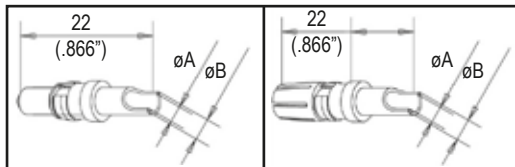

P/N		Current	Dimensions	
Pin	Socket		A mm (inch)	B mm (inch)
L 17DM 53745-8	L 17DM 53744-7	10 to 20 Amp.	1.80 (.071")	2.55 (.100")
L 17DM 53745-7	L 17DM 53744-6	20 to 30 Amp.	2.80 (.110")	3.70 (.145")
L 17DM 53745-1	L 17DM 53744-1	30 to 40 Amp.	4.80 (.189")	5.60 (.220")

Trim dimensions: 7.5 mm (.295")

Crimp version

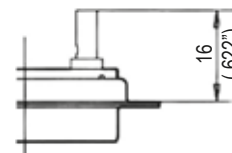
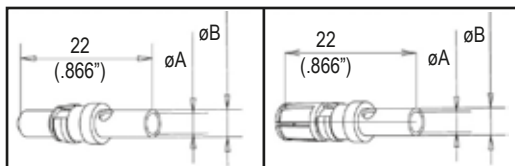

P/N		Current	Dimensions	
Pin	Socket		A mm (inch)	B mm (inch)
L 17DM 53745-208	L 17DM 53744-207	10 to 20 Amp.	1.80 (.071")	2.55 (.100")
L 17DM 53745-207	L 17DM 53744-206	20 to 30 Amp.	2.80 (.110")	3.70 (.145")
L 17DM 53745-201	L 17DM 53744-201	30 to 40 Amp.	4.80 (.189")	5.60 (.220")

Trim dimensions: 7.5 mm (.295")

Contact plating	Part number option
Flash Gold	L17DMxxxxx-x G
0.4 μ m(15 μ) Au	Standard part number as above
0.76 μ m(30 μ) Au	L17DMxxxxx-x C309

Straight shielded contacts

Crimp ferrule and inner solder

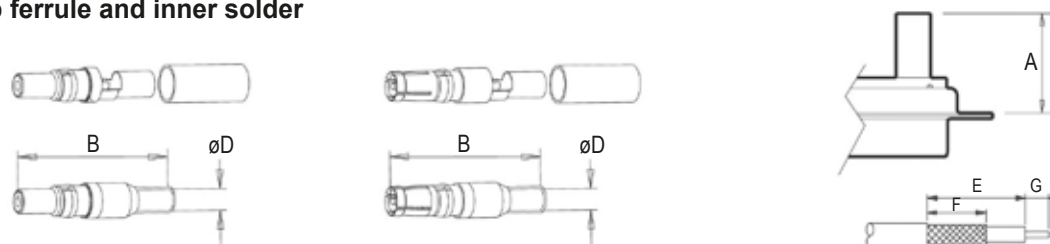

Type	P/N	Dimensions (inch)			Cable - RG	Trim dimensions (inch)		
		A Max	B	D		E	F	G
Pin	L17DM 53740	18.8 (740")	23.6 (.929")	1.0 (.039")	178 B/U	7.9 (.311")	6.3 (.248")	2 (.078")
Pin	L17DM 53740-1	18.8 (740")	23.6 (.929")	1.7 (.066")	179 B/U 316 B/U	7.9 (.311")	6.3 (.248")	2 (.078")
Pin	L17DM 53740-3	21.5 (846")	23.6 (.929")	2.8 (.110")	180 B/U	9.5 (.374")	7.9 (.311")	2 (.078")
Pin	L17DM 53740-5	21.5 (846")	23.6 (.929")	3.2 (.126")	58 C/U	9.5 (.374")	7.9 (.311")	2 (.078")
Socket	L17DM 53742	18.8 (740")	23.6 (.929")	1.0 (.039")	178 B/U	7.9 (.311")	6.3 (.248")	2 (.078")
Socket	L17DM 53742-1	18.8 (740")	23.6 (.929")	1.7 (.066")	179 B/U 316 B/U	7.9 (.311")	6.3 (.248")	2 (.078")
Socket	L17DM 53742-3	21.5 (846")	23.6 (.929")	2.8 (.110")	180 B/U	9.5 (.374")	7.9 (.311")	2 (.078")
Socket	L17DM 53742-5	21.5 (846")	23.6 (.929")	3.2 (.126")	58 C/U	9.5 (.374")	7.9 (.311")	2 (.078")

Ferrule and inner solder

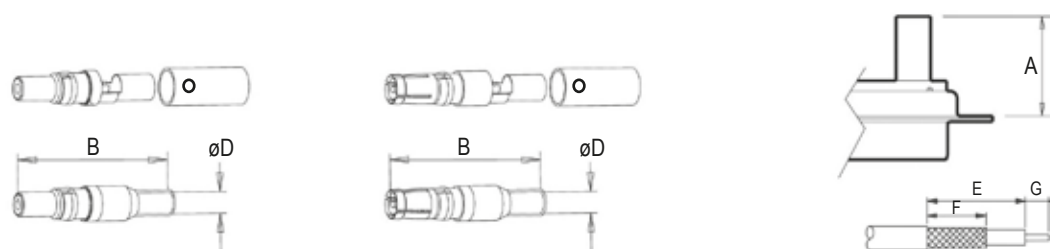

Type	P/N	Dimensions (inch)			Cable - RG	Trim dimensions (inch)		
		A Max	B	D		E	F	G
short Pin	L17DM 53740-5000	17.0 (669")	21.8 (.858")	1.0 (.039")	178 B/U	7.9 (.311")	6.3 (.248")	2 (.078")
Pin	L17DM 53740-5001	18.8 (740")	23.6 (.929")	1.7 (.066")	179 B/U 316 B/U	7.9 (.311")	6.3 (.248")	2 (.078")
Pin	L17DM 53740-5002	21.5 (846")	26.3 (1.035")	2.8 (.110")	180 B/U	9.5 (.374")	7.9 (.311")	2 (.078")
Pin	L17DM 53740-5005	21.5 (846")	26.3 (1.035")	3.2 (.126")	58 C/U	9.5 (.374")	7.9 (.311")	2 (.078")
Pin	L17DM 53740-5008	18.8 (740")	23.6 (.929")	1.0 (.039")	178 B/U	7.9 (.311")	6.3 (.248")	2 (.078")
short Socket	L17DM 53742-5000	17.0 (669")	21.8 (.858")	1.0 (.039")	178 B/U	7.9 (.311")	6.3 (.248")	2 (.078")
Socket	L17DM 53742-5001	18.8 (740")	23.6 (.929")	1.7 (.066")	179 B/U 316 B/U	7.9 (.311")	6.3 (.248")	2 (.078")
Socket	L17DM 53742-5002	21.5 (846")	26.3 (1.035")	2.8 (.110")	180 B/U	9.5 (.374")	7.9 (.311")	2 (.078")
Socket	L17DM 53742-5004	21.5 (846")	26.3 (1.035")	3.2 (.126")	58 C/U	9.5 (.374")	7.9 (.311")	2 (.078")
Socket	L17DM 53742-5006	18.8 (740")	23.6 (.929")	1.0 (.039")	178 B/U	7.9 (.311")	6.3 (.248")	2 (.078")

Right angled shielded contact

Crimp ferrule and inner solder

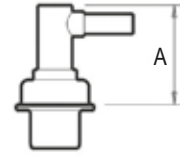
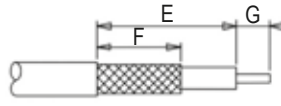
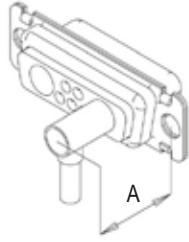

Type	P/N	Dimensions (inch)			Cable - RG	Trim dimensions (inch)		
		A Max	B	D		E	F	G
Pin	L17DM 53741	13.5 (.531")	18.6 (.732")	1.0 (.039")	178 B/U	9.5 (.374")	5.9 (.232")	1.6 (.062")
Pin	L17DM 53741-1	13.5 (.531")	18.6 (.732")	1.7 (.066")	179 B/U 316 B/U	9.5 (.374")	5.9 (.232")	1.6 (.062")
Pin	L17DM 53741-3	13.5 (.531")	18.6 (.732")	2.8 (.110")	180 B/U	10.7 (.421")	7.9 (.311")	2.4 (.094")
Pin	L17DM 53741-4	13.5 (.531")	18.6 (.732")	3.2 (.126")	58 C/U	10.7 (.421")	7.9 (.311")	2.4 (.094")
Socket	L17DM 53743-2	13.5 (.531")	18.6 (.732")	1.0 (.039")	178 B/U	9.5 (.374")	5.9 (.232")	1.6 (.062")
Socket	L17DM 53743-3	13.5 (.531")	18.6 (.732")	1.7 (.066")	179 B/U 316 B/U	9.5 (.374")	5.9 (.232")	1.6 (.062")
Socket	L17DM 53743-5	13.5 (.531")	18.6 (.732")	2.8 (.110")	180 B/U	10.7 (.421")	7.9 (.311")	2.4 (.094")
Socket	L17DM 53743-6	13.5 (.531")	18.6 (.732")	3.2 (.126")	58 C/U	10.7 (.421")	7.9 (.311")	2.4 (.094")

Ferrule and inner solder

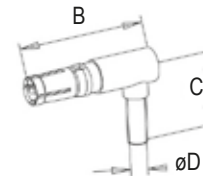
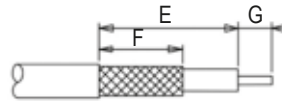
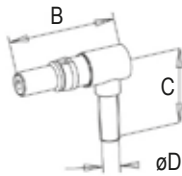

Type	P/N	Dimensions (inch)			Cable - RG	Trim dimensions (inch)		
		A Max	B	D		E	F	G
Pin	L17DM 53741-5000	13.5 (.531")	18.6 (.732")	1.0 (.039")	178 B/U	9.5 (.374")	5.9 (.232")	1.6 (.062")
Pin	L17DM 53741-5001	13.5 (.531")	18.6 (.732")	1.7 (.066")	179 B/U 316 B/U	9.5 (.374")	5.9 (.232")	1.6 (.062")
Pin	L17DM 53741-5003	13.5 (.531")	18.6 (.732")	2.8 (.110")	180 B/U	10.7 (.421")	7.9 (.311")	2.4 (.094")
Pin	L17DM 53741-5004	13.5 (.531")	18.6 (.732")	3.2 (.126")	58 C/U	10.7 (.421")	7.9 (.311")	2.4 (.094")
Socket	L17DM 53743-5000	13.5 (.531")	18.6 (.732")	1.0 (.039")	178 B/U	9.5 (.374")	5.9 (.232")	1.6 (.062")
Socket	L17DM 53743-5001	13.5 (.531")	18.6 (.732")	1.7 (.066")	179 B/U 316 B/U	9.5 (.374")	5.9 (.232")	1.6 (.062")
Socket	L17DM 53743-5003	13.5 (.531")	18.6 (.732")	2.8 (.110")	180 B/U	10.7 (.421")	7.9 (.311")	2.4 (.094")
Socket	L17DM 53743-5004	13.5 (.531")	18.6 (.732")	3.2 (.126")	58 C/U	10.7 (.421")	7.9 (.311")	2.4 (.094")

Crimping tool

Hand crimp tool

227-0944 (without dies) (M 22 520/5-01)

RG cables	MIL reference	Amphenol P/N	dim. between 2 flat surface	
			cavity A	cavity B
RG 58 C/U	M 22 520/5-05	227 1221-05	5.41	-
RG 178 B/U	M 22 520/5-03	227 1221-03	-	2.67
RG 179 B/U	M 22 520/5-03	227 1221-03	3.25	-
RG 180 B/U	M 22 520/5-05	227 1221-05	-	4.52

Extraction & crimping tools

Extraction tool for sizes 8 cts
L17D429SP



Crimping tool for all sizes
L17D479SP



Cabling instructions for shielded contacts

Straight crimp shielded contacts:

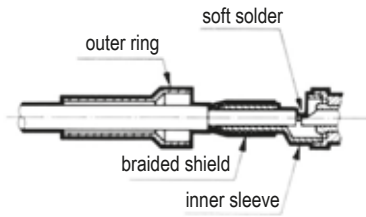

inner solder contact outer crimp contact

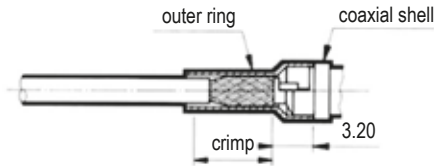

Right angle crimp shielded contacts:

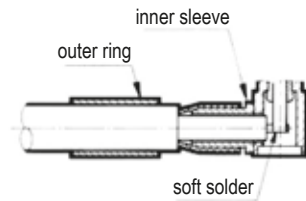

inner solder contact outer crimp contact

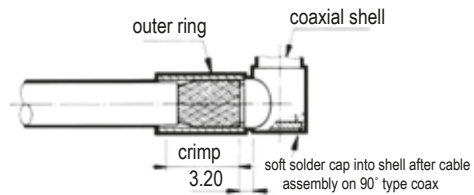

Assembly method

- Slide the outer ring over the cable jacket. Trim the cable according to the recommended dimensions.
- Insert the cable dielectric and the center conductor inside the inner sleeve.
- Solder the central conductor to the shielded center contacts.
- Slide the outer ring towards the inner sleeve and recover the braid.
- Using crimp hand tool equipped with the appropriate dies, crimp in the area defined.

Solder straight shielded contacts:

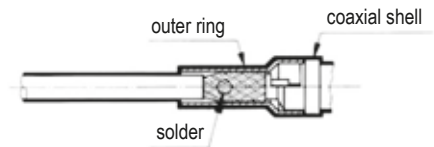
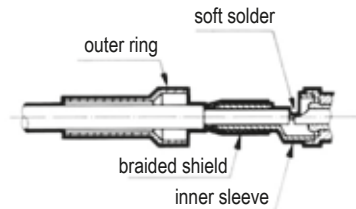

Solder right angle shielded contacts:

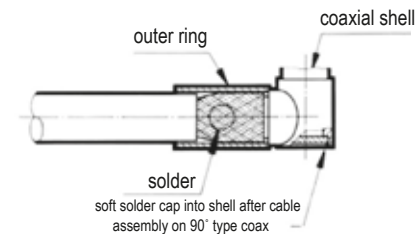
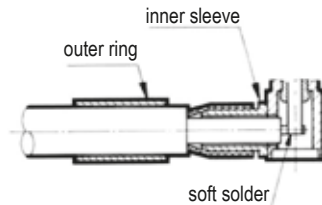

Assembly method

- Slide the outer ring over the cable jacket. Trim the cable according to the recommended dimensions.
- Insert the cable dielectric and the center conductor inside the inner sleeve.
- Solder the central conductor to the shielded center contacts.
- Slide the outer ring towards the inner sleeve and recover the braid.
- Solder by introducing metal through the outer ring hole.

Hybrid Connectors - How to order

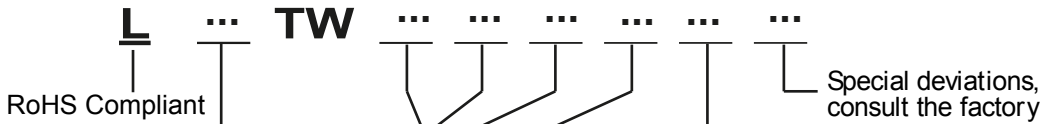

Cont
act
pla
ting

Flash**	76	Tinned shell for receptacle
	716	Tinned shell + dimples for Pin connector
0.38µm (15µ")	77	Tinned shell for receptacle
	717	Tinned shell + dimples for Pin connector
0.76µm (30µ")	177	Tinned shell for receptacle
	777	Tinned shell + dimples for Pin connector

** Signal and Power contacts only

Shell size and Configuration:				
E2W2	♦P2W2	E5W1	A3W3	♦P3W3
A7W2	A11W1	B5W5	B9W4	B13W3
B17W2	B21W1	C8W8	C13W6	C17W5
C21WA4	C25W3	C27W2	D24W7	D36W4
♦ Keyed housing				

Contact type:	
P	= Pin
S	= Socket

PCB mounting options:	
Straight connector	
BLANK	= Without standoff and boardlocks
RM53	= M3 threaded standoff with boardlocks
RM54	= 4-40 threaded standoff with boardlocks
RM83	= Removable M3 front screwlocks + RM53
RM84	= Fixed 4-40 front screwlocks + standoff and boardlocks (Combo)
Right Angle connector	
BLANK	= Metal bracket with 3.1mm clear hole
RM6	= Metal bracket with boardlocks

Panel mounting options:	
BLANK	= Ø3.1mm (.122") rivet
3F	= Fixed M3 front screwlock
3R	= Rear M3 threaded insert
4F	= Fixed 4-40 front screwlock
3R	= Rear 4-40 threaded insert
VFM2	= M3 removable front screwlock
VF2	= 4-40 removable front screwlock
FM	= Float mounting bushing
A514	= Blindmate guide pin

Termination:	
Straight PCB & Solder-cup	
BLANK	= Solder-cup signal contacts only
P3SY	= 20~40Amp power & signal mix
P2SY	= 10~20Amp power & signal mix
CSY	= Coax & signal mix
SY	= Signal only
P3Y	= 20~40Amp power only (2W2, 3W3, 5W5, 8W8)
P2Y	= 10~20Amp power only (2W2, 3W3, 5W5, 8W8)
CY	= Coax only (2W2, 3W3, 5W5, 8W8)
Right Angle PCB	
MP3SV	= US footprint, 20~40Amp power & signal mix
MP2SV	= US footprint, 10~20Amp power & signal mix
MCSV	= US footprint, coax & signal mix
MSV	= US footprint, signal only
MP3V	= US footprint, 20~40Amp power only (2w2, 3W3, 5W5, 8W8)
MP2V	= US footprint, 10~20Amp power only (2w2, 3W3, 5W5, 8W8)
Right Angle PCB cont.,	
MCV	= US footprint, coax only (2W2, 3W3, 5W5, 8W8)
EP3SV	= European footprint, 20~40Amp power & signal mix
EP2SV	= European footprint, 10~20Amp power & signal mix
ESV	= European footprint, signal only
EP3V	= European footprint, 20~40Amp power only (2W2, 3W3, 5W5, 8W8)
EP2V	= European footprint, 10~20Amp power only (2W2, 3W3, 5W5, 8W8)
HP3SV	= Mixed footprint, 20~40Amp power & signal mix
HP2SV	= Mixed footprint, 10~20Amp power & signal mix
HCSV	= Mixed footprint, coax & signal mix
HSV	= Mixed footprint, signal only
HP3V	= Mixed footprint, 20~40Amp power only (2W2, 3W3, 5W5, 8W8)
HP2V	= Mixed footprint, 10~20Amp power only (2W2, 3W3, 5W5, 8W8)
HCV	= Mixed footprint, coax only (2W2, 3W3, 5W5, 8W8)

Example: L717 TW B9W4 S MP3V 4F RM6