

SPECIFICATIONS	
CONTACT CARRIER MATERIAL	NYLON OR TPU
MOLDED HEAD MATERIAL/COLOR	PVC/BLACK
CONTACT MATERIAL/PLATING	BRASS/GOLD
COUPLING NUT MATERIAL/FINISH	STAINLESS STEEL/PASSIVATED
RATED CURRENT [A]	4.0 A
RATED VOLTAGE [V]	125 VAC/VDC
OUTER JACKET MATERIAL/COLOR	PVC/BLACK
CONDUCTOR INSULATION MATERIAL	PVC
NUMBER OF CONDUCTORS [AWG]	3x24 AWG
TEMPERATURE RATING	-40°C TO +105°C (-40°F TO +221°F)
PROTECTION CLASS	MEETS NEMA 1,3,4,6P AND IEC IP67

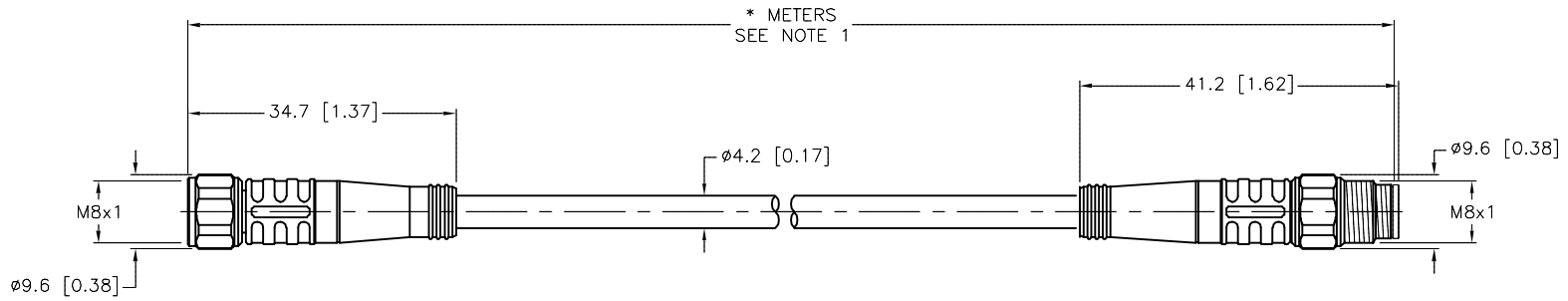

CABLE LENGTH	TOLERANCE*
ALL LENGTHS	+ 4% (OR 50mm) OF LENGTH - 0% (OR 0mm) OF LENGTH WHICHEVER IS GREATER
STRIP LENGTH	TOLERANCE*
0-7mm	±0.5mm
8-29mm	±1.0mm
30-49mm	±2.0mm
50-69mm	±3.0mm
70-100mm	±4.0mm
OVER 100mm	±5.0mm
* UNLESS OTHERWISE SPECIFIED	

- NOTES:
- "*" INDICATES CABLE LENGTH IN METERS. CONTACT TURCK TO ORDER SPECIFIC LENGTHS.
 - "/S760" DESIGNATES BLACK CABLE JACKET.
 - "/S771" DESIGNATES BLACK MOLDED PLUG BODIES.
 - "/S1037" DESIGNATES PVC PLUG BODY.
 - "/S1579" DESIGNATES NO FLAG LABEL.

SOURCE DRAWING - FOR REFERENCE ONLY

RELATED DOCUMENTS 1. 2. 3. 4.	3RD ANGLE PROJECTION 	THIS DRAWING IS CONFIDENTIAL AND THE PROPERTY OF TURCK INC. USE OF THIS DOCUMENT WITHOUT WRITTEN PERMISSION IS PROHIBITED.		<p>3000 CAMPUS DRIVE MINNEAPOLIS, MN 55441 1-800-544-7769 (763) 553-7300 (763) 553-0708 fax www.turck.us</p>
	MATERIAL	DRFT KMY	DATE 06/19/14	
FINISH	ALL DIMENSIONS DISPLAYED ON THIS DRAWING ARE FOR REFERENCE ONLY	APVD N.M.	SCALE 1=1.0	IDENTIFICATION NO.
B UPDATE DESCRIPTION	TR 04/04/17	UNIT OF MEASUREMENT MILLIMETER [INCH]		REV B
REV DESCRIPTION	BY DATE ECO NO.	CONTACT TURCK FOR MORE INFORMATION		FILE: 777033643
DO NOT SCALE THIS DRAWING				SHEET 1 OF 1

B	UPDATE DESCRIPTION	TR	04/04/17	59099
REV	DESCRIPTION	BY	DATE	ECO NO.