

MALE END VIEW	FEMALE END VIEW	WIRING DIAGRAM	SPECIFICATIONS																			
			<table border="1"> <tr><td>CONTACT CARRIER MATERIAL/COLOR</td><td>NYLON OR TPU/BLACK</td></tr> <tr><td>MOLDED HEAD MATERIAL/COLOR</td><td>TPU/YELLOW</td></tr> <tr><td>CONTACT MATERIAL/PLATING</td><td>BRASS/GOLD</td></tr> <tr><td>COUPLING NUT MATERIAL/PLATING</td><td>BRASS/NICKEL</td></tr> <tr><td>RATED CURRENT</td><td>2.0 A</td></tr> <tr><td>RATED VOLTAGE</td><td>125 VAC/VDC</td></tr> <tr><td>NUMBER OF CONDUCTORS [AWG]</td><td>PRINTED CIRCUIT PINS</td></tr> <tr><td>TEMPERATURE RATING</td><td>-30°C to +80°C (-22°F to +176°F)</td></tr> <tr><td>PROTECTION CLASS</td><td>MEETS NEMA 1,3,4,6P AND IEC IP67</td></tr> </table>	CONTACT CARRIER MATERIAL/COLOR	NYLON OR TPU/BLACK	MOLDED HEAD MATERIAL/COLOR	TPU/YELLOW	CONTACT MATERIAL/PLATING	BRASS/GOLD	COUPLING NUT MATERIAL/PLATING	BRASS/NICKEL	RATED CURRENT	2.0 A	RATED VOLTAGE	125 VAC/VDC	NUMBER OF CONDUCTORS [AWG]	PRINTED CIRCUIT PINS	TEMPERATURE RATING	-30°C to +80°C (-22°F to +176°F)	PROTECTION CLASS	MEETS NEMA 1,3,4,6P AND IEC IP67	
CONTACT CARRIER MATERIAL/COLOR	NYLON OR TPU/BLACK																					
MOLDED HEAD MATERIAL/COLOR	TPU/YELLOW																					
CONTACT MATERIAL/PLATING	BRASS/GOLD																					
COUPLING NUT MATERIAL/PLATING	BRASS/NICKEL																					
RATED CURRENT	2.0 A																					
RATED VOLTAGE	125 VAC/VDC																					
NUMBER OF CONDUCTORS [AWG]	PRINTED CIRCUIT PINS																					
TEMPERATURE RATING	-30°C to +80°C (-22°F to +176°F)																					
PROTECTION CLASS	MEETS NEMA 1,3,4,6P AND IEC IP67																					

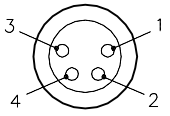
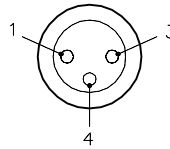
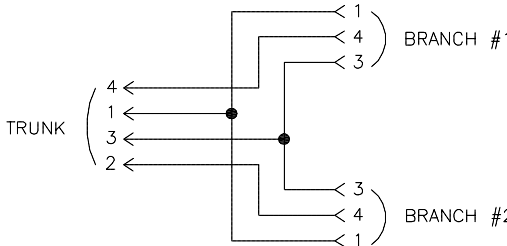
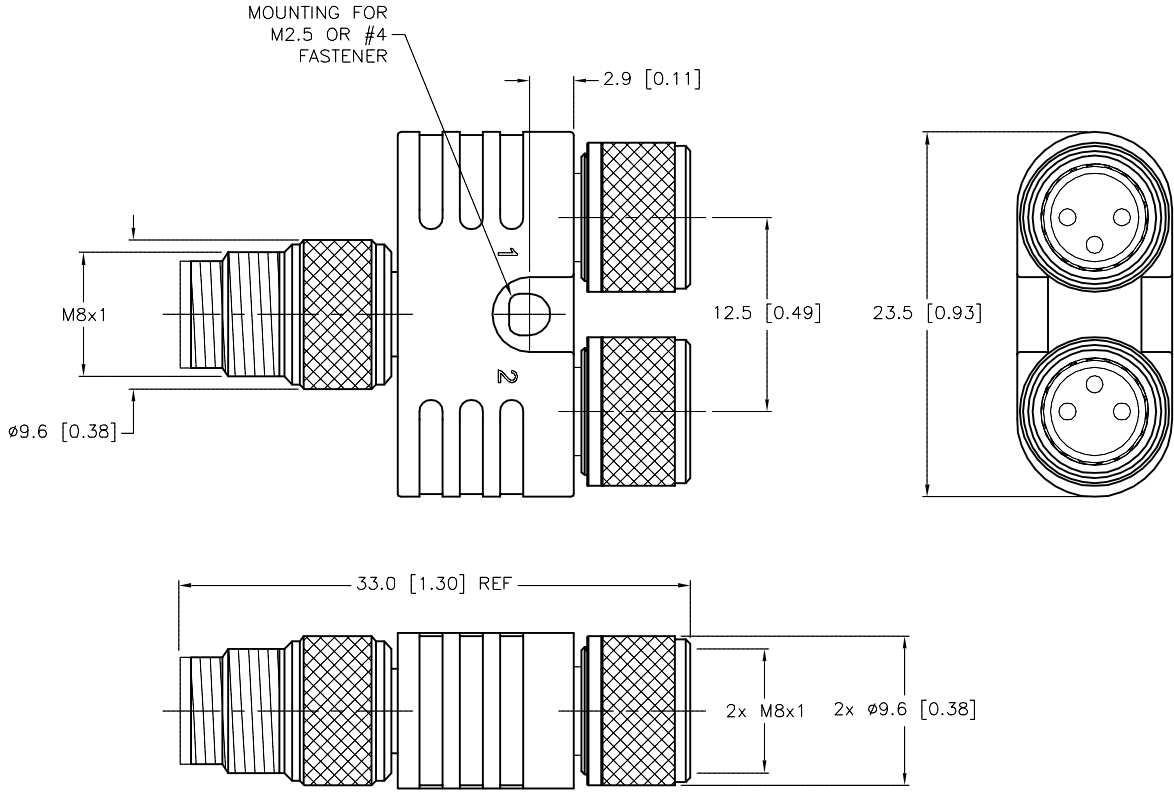
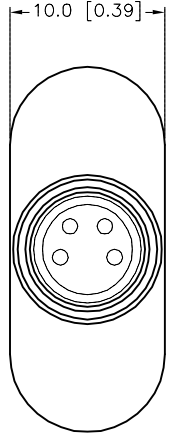
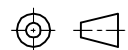

SOURCE DRAWING - FOR REFERENCE ONLY

RELATED DOCUMENTS 1. 2. 3. 4.	3RD ANGLE PROJECTION 	THIS DRAWING IS CONFIDENTIAL AND THE PROPERTY OF TURCK INC. USE OF THIS DOCUMENT WITHOUT WRITTEN PERMISSION IS PROHIBITED.	<div style="text-align: right;"> <p>3000 CAMPUS DRIVE MINNEAPOLIS, MN 55441 1-800-544-7769 (763) 553-7300 (763) 553-0708 fax turck.com</p> </div>	
MATERIAL SEE SPECIFICATIONS	ALL DIMENSIONS DISPLAYED ON THIS DRAWING ARE FOR REFERENCE ONLY	DRFT JBJ DATE 02/12/04 APVD SCALE 1=.5	DESCRIPTION YP2-MFS 4/2MFK 3	
FINISH SEE SPECIFICATIONS	CONTACT TURCK FOR MORE INFORMATION	UNIT OF MEASUREMENT MILLIMETER [INCH] IDENTIFICATION NO. U0932-33 REV D		
D UPDATE MALE COUPLING NUT	RDS 06/12/13 40191	DO NOT SCALE THIS DRAWING		
REV DESCRIPTION	BY DATE ECO NO.	FILE: U0932-33	SHEET 1 OF 1	