

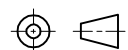

| CABLE LENGTH | TOLERANCE*                                                                  |
|--------------|-----------------------------------------------------------------------------|
| ALL LENGTHS  | + 4% (OR 50mm) OF LENGTH<br>- 0% (OR 0mm) OF LENGTH<br>WHICHEVER IS GREATER |
| STRIP LENGTH | TOLERANCE*                                                                  |
| 0-7mm        | ±0.5mm                                                                      |
| 8-29mm       | ±1.0mm                                                                      |
| 30-49mm      | ±2.0mm                                                                      |
| 50-69mm      | ±3.0mm                                                                      |
| 70-100mm     | ±4.0mm                                                                      |
| OVER 100mm   | ±5.0mm                                                                      |

\* UNLESS OTHERWISE SPECIFIED

**SOURCE DRAWING - FOR REFERENCE ONLY**

NOTES:  
1. "\*" INDICATES CABLE LENGTH IN METERS. CONTACT TURCK TO ORDER SPECIFIC LENGTHS.

|                                           |                                                                                                               |                                                                                                                            |                              |                                                                                                                      |              |
|-------------------------------------------|---------------------------------------------------------------------------------------------------------------|----------------------------------------------------------------------------------------------------------------------------|------------------------------|----------------------------------------------------------------------------------------------------------------------|--------------|
| RELATED DOCUMENTS<br>1.<br>2.<br>3.<br>4. | 3RD ANGLE PROJECTION<br> | THIS DRAWING IS CONFIDENTIAL AND THE PROPERTY OF TURCK INC. USE OF THIS DOCUMENT WITHOUT WRITTEN PERMISSION IS PROHIBITED. |                              | 3000 CAMPUS DRIVE<br>MINNEAPOLIS, MN 55441<br>1-800-544-7769<br>(763) 553-7300<br>(763) 553-0708 fax<br>www.turck.us |              |
|                                           |                                                                                                               | DRFT *CK<br>APVD                                                                                                           | DATE 11/15/10<br>SCALE 1=1.0 |                                 |              |
| MATERIAL                                  | ALL DIMENSIONS DISPLAYED ON THIS DRAWING ARE FOR REFERENCE ONLY<br><br>CONTACT TURCK FOR MORE INFORMATION     | UNIT OF MEASUREMENT<br><b>MILLIMETER [ INCH ]</b>                                                                          |                              | DESCRIPTION<br>PKW 4M-*--PSW 3M                                                                                      |              |
| FINISH                                    |                                                                                                               | DO NOT SCALE THIS DRAWING                                                                                                  |                              | IDENTIFICATION NO.                                                                                                   | REV<br>E     |
| E UPDATE FEMALE END VIEW                  | RDS 06/19/17                                                                                                  | 60876                                                                                                                      | FILE: 777026959              |                                                                                                                      | SHEET 1 OF 1 |
| REV DESCRIPTION                           | BY DATE                                                                                                       | ECO NO.                                                                                                                    |                              |                                                                                                                      |              |