

FEMALE END VIEW

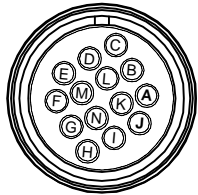

- A = GRAY
- B = GRAY/BROWN
- C = BROWN
- D = TAN
- E = BLUE
- F = RED
- G = WHITE
- H = RED/BLUE
- I = GRAY/PINK
- J = VIOLET
- K = YELLOW
- L = ORANGE
- M = PINK
- N = BLACK

CONNECTOR
 TYPE/STYLE - MS 3106M
 SHELL SIZE - 20
 INSERT ARRANGEMENT - 27SY

SPECIFICATIONS

CONTACT CARRIER MATERIAL	NEOPRENE
MOLDED HEAD MATERIAL/COLOR	PVC/BLACK
CONTACT MATERIAL/PLATING	COPPER ALLOY/SILVER
COUPLING NUT MATERIAL/PLATING	ALUMINUM ALLOY/OLIVE DRAB CHROMATE
MOLD SLEEVE	ALUMINUM/BLACK ANODIZED
RATED CURRENT [A]	3.5 A
RATED VOLTAGE [V]	500 V
OUTER JACKET MATERIAL/COLOR	TPE/BLACK
CONDUCTOR INSULATION MATERIAL	POLYESTER ELASTOMER
NUMBER OF CONDUCTORS	15x22 AWG
TEMPERATURE RATING	-40°C to +105°C (-40°F to +221°F)
PROTECTION CLASS	MEETS NEMA 1,3,4,6P AND IEC IP67, IP68
CONNECTOR TYPE	MIL-DTL-5015

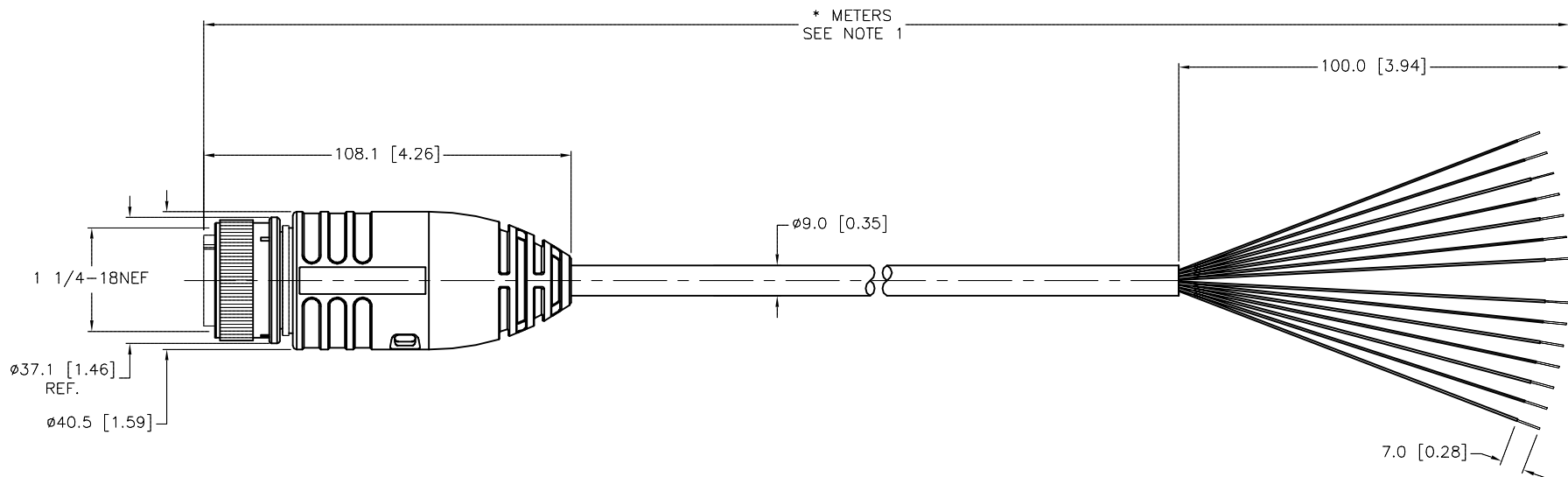

* METERS
 SEE NOTE 1

CABLE LENGTH	TOLERANCE*
ALL LENGTHS	+ 4% (OR 50mm) OF LENGTH - 0% (OR 0mm) OF LENGTH WHICHEVER IS GREATER
STRIP LENGTH	TOLERANCE*
0-7mm	±0.5mm
8-29mm	±1.0mm
30-49mm	±2.0mm
50-69mm	±3.0mm
70-100mm	±4.0mm
OVER 100mm	±5.0mm

* UNLESS OTHERWISE SPECIFIED

NOTES:

- "*" INDICATES CABLE LENGTH IN METERS. CONTACT TURCK TO ORDER SPECIFIC LENGTH.
- UNUSED CONDUCTOR TRIMMED BACK TO CABLE JACKET ON BOTH ENDS.

SOURCE DRAWING - FOR REFERENCE ONLY

RELATED DOCUMENTS 1. 2. 3. 4.	3RD ANGLE PROJECTION 	THIS DRAWING IS CONFIDENTIAL AND THE PROPERTY OF TURCK INC. USE OF THIS DOCUMENT WITHOUT WRITTEN PERMISSION IS PROHIBITED.		3000 CAMPUS DRIVE MINNEAPOLIS, MN 55441 1-800-544-7769 (763) 553-7300 (763) 553-0708 fax turck.com		
		DRFT	RDS	DATE	03/11/15	DESCRIPTION MS 3106M-20-27SY-1000-*
		APVD	F.M.	SCALE	1=2.0	
		MATERIAL SEE SPECIFICATIONS	ALL DIMENSIONS DISPLAYED ON THIS DRAWING ARE FOR REFERENCE ONLY	UNIT OF MEASUREMENT MILLIMETER [INCH]		IDENTIFICATION NO.
FINISH SEE SPECIFICATIONS	CONTACT TURCK FOR MORE INFORMATION			DO NOT SCALE THIS DRAWING	FILE: 777034879	
P2	UPDATE DESCRIPTION	NDF	03/12/15			
REV	DESCRIPTION	BY	DATE	ECO NO.	SHEET 1 OF 1	