

FEMALE END VIEW

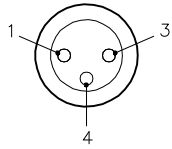

1 = BROWN
 3 = BLUE
 4 = BLACK



SPECIFICATIONS

CONTACT CARRIER MATERIAL	NYLON OR TPU
MOLDED HEAD MATERIAL/COLOR	TPU/BLACK
CONTACT MATERIAL/PLATING	BRASS/GOLD
COUPLING NUT MATERIAL/PLATING	BRASS/NICKEL
RATED CURRENT [A]	4.0 A
RATED VOLTAGE [V]	125 VAC/VDC
OUTER JACKET MATERIAL/COLOR	TPU/BLACK
CONDUCTOR INSULATION MATERIAL	PVC
NUMBER OF CONDUCTORS [AWG]	3x24 AWG
TEMPERATURE RATING	-40°C TO +90°C (-40°F TO +194°F)
PROTECTION CLASS	MEETS NEMA 1,3,4,6P AND IEC IP67

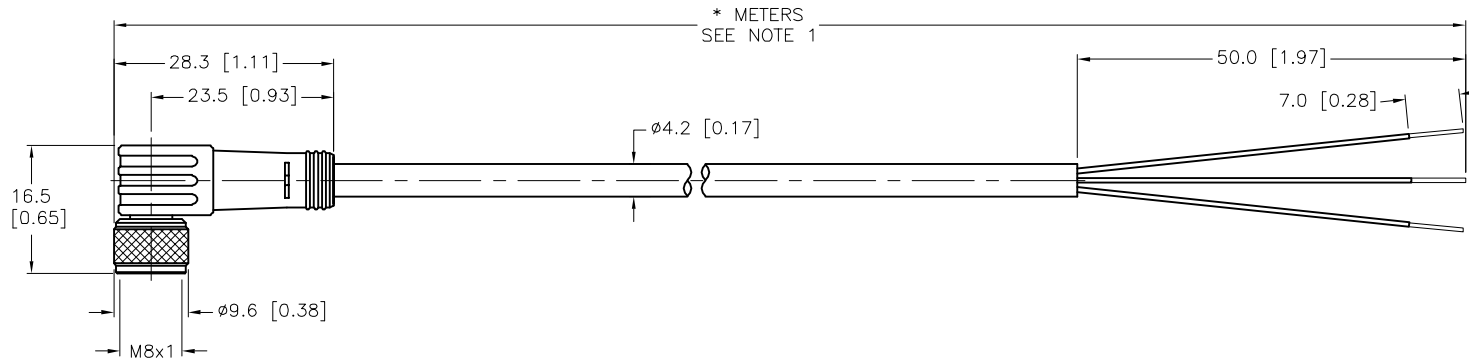

CABLE LENGTH	TOLERANCE*
ALL LENGTHS	+ 4% (OR 50mm) OF LENGTH - 0% (OR 0mm) OF LENGTH WHICHEVER IS GREATER
STRIP LENGTH	TOLERANCE*
0-7mm	±0.5mm
8-29mm	±1.0mm
30-49mm	±2.0mm
50-69mm	±3.0mm
70-100mm	±4.0mm
OVER 100mm	±5.0mm
* UNLESS OTHERWISE SPECIFIED	

SOURCE DRAWING - FOR REFERENCE ONLY

NOTES:

- "*" INDICATES CABLE LENGTH IN METERS. CONTACT TURCK TO ORDER SPECIFIC LENGTHS.
- "/S90" DESIGNATES THERMOPLASTIC POLYURETHANE (TPU) CABLE JACKET.
- "/S771" DESIGNATES BLACK MOLD BODY.

RELATED DOCUMENTS	3RD ANGLE PROJECTION	THIS DRAWING IS CONFIDENTIAL AND THE PROPERTY OF TURCK INC. USE OF THIS DOCUMENT WITHOUT WRITTEN PERMISSION IS PROHIBITED.		3000 CAMPUS DRIVE MINNEAPOLIS, MN 55441 1-800-544-7769 (763) 553-7300 (763) 553-0708 fax www.turck.us	
1.		DRFT	RWC	DATE 07/01/09	DESCRIPTION PKW 3M-*/S90/S771
2.		APVD		SCALE 1=1.0	
3.	ALL DIMENSIONS DISPLAYED ON THIS DRAWING ARE FOR REFERENCE ONLY	UNIT OF MEASUREMENT			IDENTIFICATION NO.
4.		MILLIMETER [INCH]			
MATERIAL	CONTACT TURCK FOR MORE INFORMATION	DO NOT SCALE THIS DRAWING			REV F
SEE SPECIFICATIONS		FILE: 777024876			SHEET 1 OF 1
FINISH					
SEE SPECIFICATIONS					

F	UPDATE CABLE OD	CK	08/10/11	35981
REV	DESCRIPTION	BY	DATE	ECO NO.