

FEMALE END VIEW

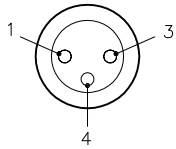

- 1 = BROWN
- 3 = BLUE
- 4 = BLACK



SPECIFICATIONS

CONTACT CARRIER MATERIAL	NYLON OR TPU
MOLDED HEAD MATERIAL/COLOR	TPU/YELLOW
CONTACT MATERIAL/PLATING	BRASS/GOLD
COUPLING NUT MATERIAL/PLATING	BRASS/NICKEL
RATED CURRENT [A]	4.0 A
RATED VOLTAGE [V]	125 VAC/VDC
OUTER JACKET MATERIAL/COLOR	TPU/BLACK
CONDUCTOR INSULATION MATERIAL	PVC
NUMBER OF CONDUCTORS [AWG]	4x26 AWG
TEMPERATURE RATING	-40°C TO +90°C (-40°F TO +194°F)
PROTECTION CLASS	MEETS NEMA 1,3,4,6P AND IEC IP67

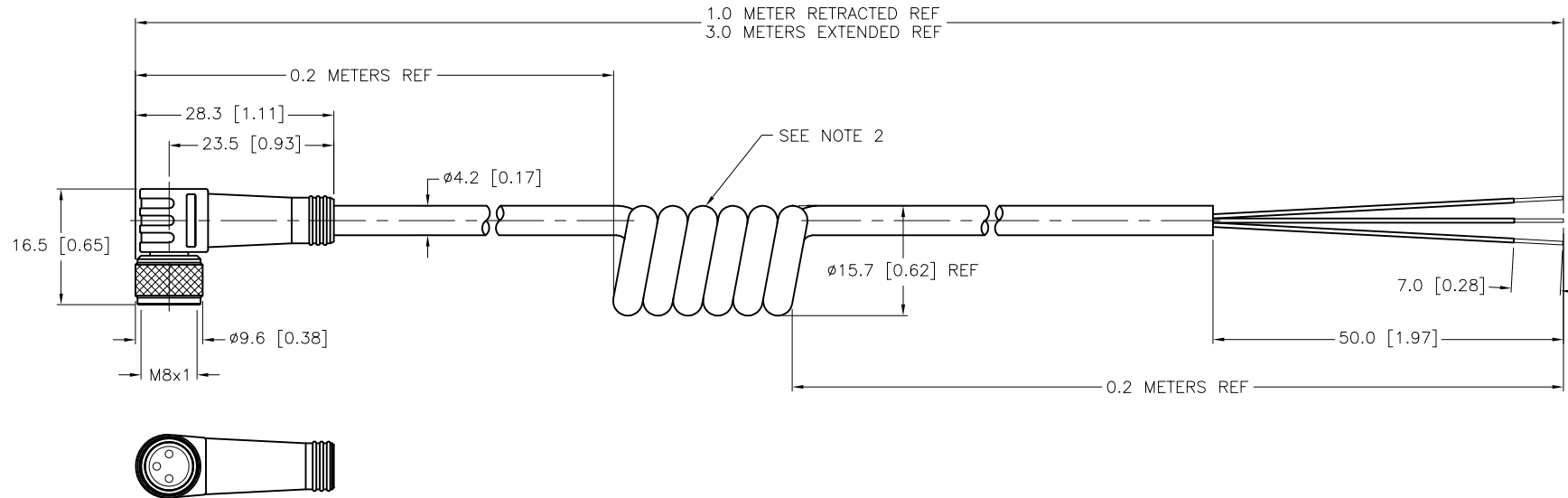

SOURCE DRAWING - FOR REFERENCE ONLY

NOTES:

1. "/S90" DESIGNATES THERMOPLASTIC POLYURETHANE (TPU) CABLE.
2. NUMBER OF COILS IS REFERENCE ONLY.
3. WHITE WIRE TRIMMED TO CABLE JACKET.

RELATED DOCUMENTS		3RD ANGLE PROJECTION		THIS DRAWING IS CONFIDENTIAL AND THE PROPERTY OF TURCK INC. USE OF THIS DOCUMENT WITHOUT WRITTEN PERMISSION IS PROHIBITED.		TURCK INC High Technology Sensors and Automation Controls 3000 CAMPUS DRIVE MINNEAPOLIS, MN 55441 1-800-544-7769 (763) 553-7300 (763) 553-0708 fax turck.com	
1. 2. 3. 4.				DRFT RWC DATE 02/07/07 APVD SCALE 1=1.0		DESCRIPTION PKW 3M-3/S90-SP	
MATERIAL SEE SPECIFICATIONS		ALL DIMENSIONS DISPLAYED ON THIS DRAWING ARE FOR REFERENCE ONLY		UNIT OF MEASUREMENT MILLIMETER [INCH]		IDENTIFICATION NO. U0071-10	
FINISH SEE SPECIFICATIONS		CONTACT TURCK FOR MORE INFORMATION		DO NOT SCALE THIS DRAWING		REV F	
F	DRAWING PROCESSED AS PART OF ECO 39300	KMY	07/09/12	39300			
REV	DESCRIPTION	BY	DATE	ECO NO.	FILE: U0071-10		SHEET 1 OF 1