

SPECIFICATIONS	
CONTACT CARRIER MATERIAL	NYLON/BLACK
MOLDED MATERIAL/COLOR	POLYAMIDE/BLACK
CONTACT MATERIAL/PLATING	BRASS/GOLD
COUPLING NUT MATERIAL/PLATING	BRASS/NICKEL
RATED CURRENT [A]	20.0 A
RATED VOLTAGE [V]	600 V
CABLE JACKET MATERIAL/COLOR	TPE/BLACK
CONDUCTOR INSULATION MATERIAL	PVC/NYLON
NUMBERS OF CONDUCTORS [AWG]	4x12 AWG
TEMPERATURE RATING	-40°C to +90°C (-40°F to +194°F)
PROTECTION CLASS	MEETS IEC IP67

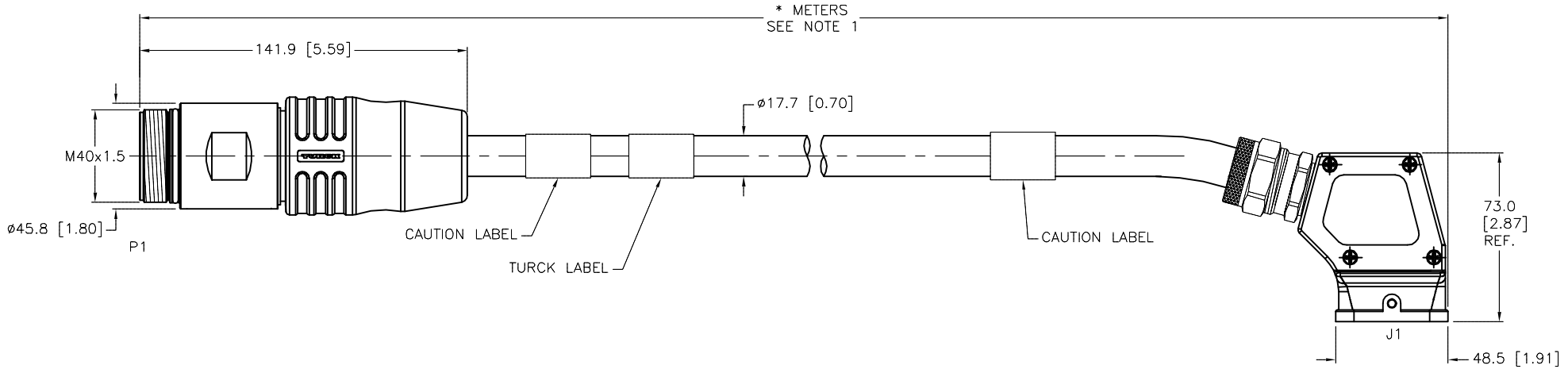

CABLE LENGTH	TOLERANCE*
ALL LENGTHS	+ 4% (OR 50mm) OF LENGTH - 0% (OR 0mm) OF LENGTH WHICHEVER IS GREATER
STRIP LENGTH	TOLERANCE*
0-7mm	±0.5mm
8-29mm	±1.0mm
30-49mm	±2.0mm
50-69mm	±3.0mm
70-100mm	±4.0mm
OVER 100mm	±5.0mm

\* UNLESS OTHERWISE SPECIFIED

**CAUTION:**  
RISK OF ELECTRICAL SHOCK  
DO NOT DISCONNECT UNDER LOAD

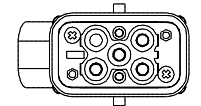

SOURCE DRAWING - FOR REFERENCE ONLY

**NOTES:**

- "\*" INDICATES CABLE LENGTH IN METERS. CONTACT TURCK TO ORDER SPECIFIC LENGTHS.
- CABLE ASSEMBLIES FOR TURCK M40 CONNECTORS ARE RATED AS STAND ALONE. OVERALL CABLE ASSEMBLY RATING IS THE RESPONSIBILITY OF THE CUSTOMER.

RELATED DOCUMENTS	3RD ANGLE PROJECTION	THIS DRAWING IS CONFIDENTIAL AND THE PROPERTY OF TURCK INC. USE OF THIS DOCUMENT WITHOUT WRITTEN PERMISSION IS PROHIBITED.		3000 CAMPUS DRIVE MINNEAPOLIS, MN 55441 1-800-544-7769 (763) 553-7300 (763) 553-0708 fax turck.com	
1.		DRFT	RDS	DATE	06/21/12
2.		APVD	E.S.	SCALE	1=2.7
3.	ALL DIMENSIONS DISPLAYED ON THIS DRAWING ARE FOR REFERENCE ONLY	UNIT OF MEASUREMENT		DESCRIPTION	
4.		MILLIMETER [ INCH ]		HSM 40 HANQW4/2-1668-*	
MATERIAL	CONTACT TURCK FOR MORE INFORMATION	IDENTIFICATION NO.		REV	
SEE SPECIFICATIONS				G	
FINISH	DO NOT SCALE THIS DRAWING	FILE: 777029134		SHEET 1 OF 1	
SEE SPECIFICATIONS					

G	UPDATE CONDUCTOR INSULATION MATERIAL	NF	07/08/16	55796
REV	DESCRIPTION	BY	DATE	ECO NO.