

FEMALE END VIEW	MALE END VIEW	WIRING DIAGRAM	SPECIFICATIONS	
			CONTACT CARRIER MATERIAL	NYLON OR TPU
			MOLDED HEAD MATERIAL/COLOR	TPU/YELLOW
			CONTACT MATERIAL/PLATING	BRASS/GOLD
			COUPLING NUT MATERIAL/PLATING	BRASS/NICKEL
			RATED CURRENT [A]	4.0 A
			RATED VOLTAGE [V]	250 V
			OUTER JACKET MATERIAL/COLOR	PVC/GREY
			CONDUCTOR INSULATION MATERIAL	PVC
			NUMBERS OF CONDUCTORS [AWG]	3x22 AWG
			TEMPERATURE RANGE	-40°C to +105°C (-40°F to +221°F)
			PROTECTION CLASS	MEETS NEMA 1,3,4,6P AND IEC IP68, IP69K

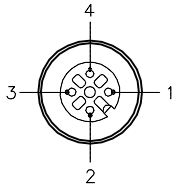
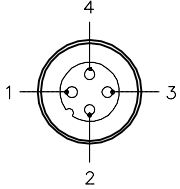
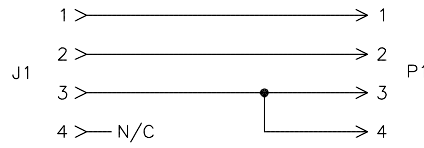
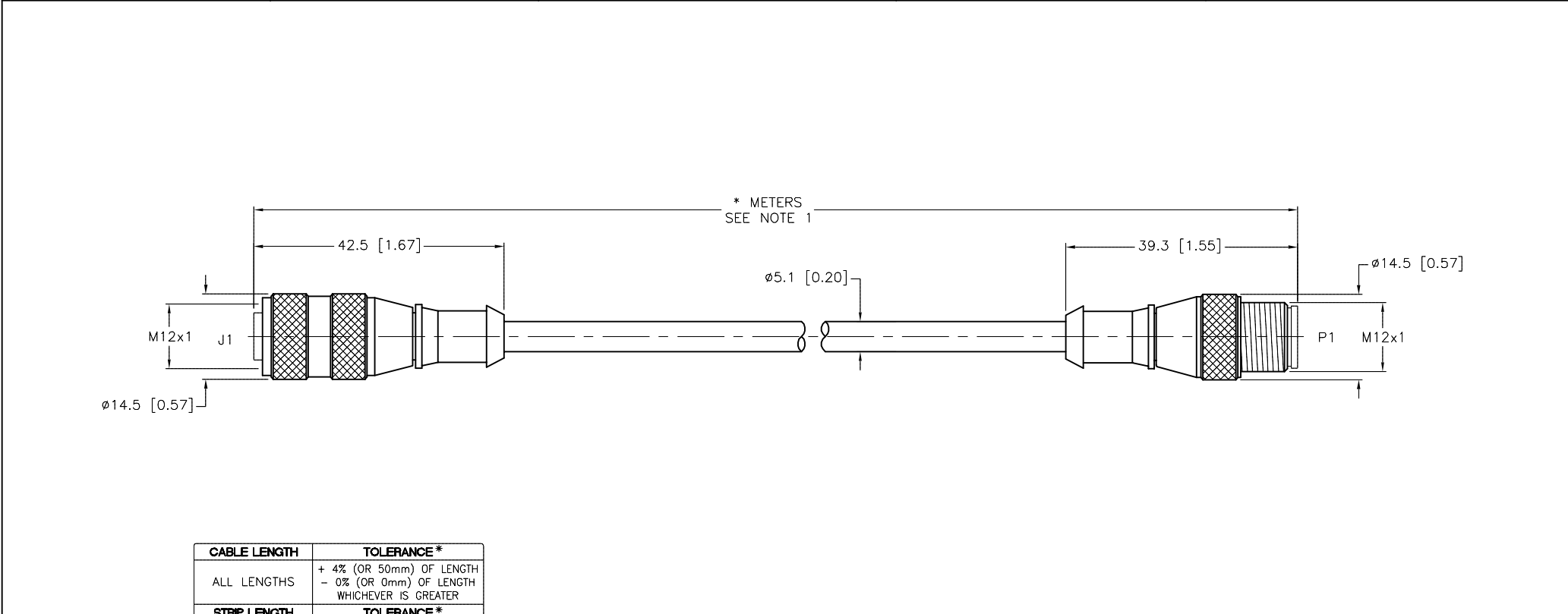

CABLE LENGTH	TOLERANCE*
ALL LENGTHS	+ 4% (OR 50mm) OF LENGTH - 0% (OR 0mm) OF LENGTH WHICHEVER IS GREATER
STRIP LENGTH	TOLERANCE*
0-7mm	±0.5mm
8-29mm	±1.0mm
30-49mm	±2.0mm
50-69mm	±3.0mm
70-100mm	±4.0mm
OVER 100mm	±5.0mm

* UNLESS OTHERWISE SPECIFIED

NOTES:

- "*" INDICATES CABLE LENGTH IN METERS. CONTACT TURCK TO ORDER SPECIFIC LENGTHS.
- "S1119" DESIGNATES WIRING TO INTERFACE BETWEEN BL67-2AI-I, BL67-4AI-I/V AND Bi(Ni)...-LIU-H1141.

SOURCE DRAWING - FOR REFERENCE ONLY

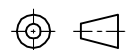
RELATED DOCUMENTS	3RD ANGLE PROJECTION	THIS DRAWING IS CONFIDENTIAL AND THE PROPERTY OF TURCK INC. USE OF THIS DOCUMENT WITHOUT WRITTEN PERMISSION IS PROHIBITED.		TURCK INC High Technology Sensors and Automation Controls 3000 CAMPUS DRIVE MINNEAPOLIS, MN 55441 1-800-544-7769 (763) 553-7300 (763) 553-0708 fax turck.com	
1.		DRFT	RWC	DATE	01/03/06
2.		APVD		SCALE	1=1.0
3.	ALL DIMENSIONS DISPLAYED ON THIS DRAWING ARE FOR REFERENCE ONLY	UNIT OF MEASUREMENT			DESCRIPTION
4.		MILLIMETER [INCH]			RK 4.4T-*--RS 4.4T/S1119
MATERIAL	SEE SPECIFICATION	CONTACT TURCK FOR MORE INFORMATION			IDENTIFICATION NO.
FINISH		SEE SPECIFICATIONS			REV
DO NOT SCALE THIS DRAWING		FILE: 777012350			G

G	UPDATE CABLE SPECIFICATIONS	KMY	05/22/14	44672
REV	DESCRIPTION	BY	DATE	ECO NO.