

FEMALE END VIEW

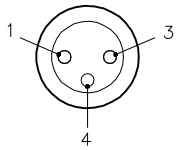

1 = BROWN
3 = BLUE
4 = BLACK



SPECIFICATIONS

CONTACT CARRIER MATERIAL	NYLON OR TPU
MOLDED HEAD MATERIAL/COLOR	TPU/YELLOW
CONTACT MATERIAL/PLATING	BRASS/GOLD
COUPLING NUT MATERIAL/PLATING	BRASS/NICKEL
RATED CURRENT [A]	4.0 A
RATED VOLTAGE [V]	125 VAC/VDC
OUTER JACKET MATERIAL/COLOR	TPU/BLACK
CONDUCTOR INSULATION MATERIAL	PVC
NUMBER OF CONDUCTORS [AWG]	3x24 AWG
TEMPERATURE RANGE	-40°C to +90°C (-40°F to +94°F)
PROTECTION CLASS	MEETS NEMA 1,3,4,6P AND IEC IP67

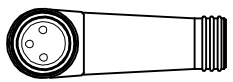
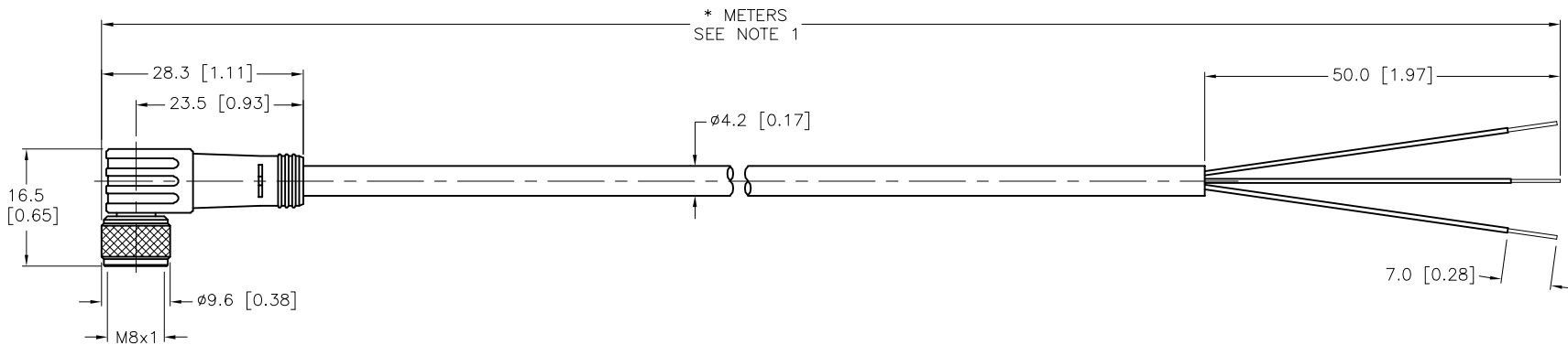

CABLE LENGTH	TOLERANCE*
ALL LENGTHS	+ 4% (OR 50mm) OF LENGTH - 0% (OR 0mm) OF LENGTH WHICHEVER IS GREATER
STRIP LENGTH	TOLERANCE*
0-7mm	±0.5mm
8-29mm	±1.0mm
30-49mm	±2.0mm
50-69mm	±3.0mm
70-100mm	±4.0mm
OVER 100mm	±5.0mm

* UNLESS OTHERWISE SPECIFIED

SOURCE DRAWING - FOR REFERENCE ONLY

NOTES:

- "*" INDICATES CABLE LENGTH IN METERS. CONTACT TURCK TO ORDER SPECIFIC LENGTHS.
- "/S90" INDICATES THERMOPLASTIC POLYURETHANE (TPU) CABLE JACKET.
- "/SV" DESIGNATES SPECIAL PACAGING FOR VENDING MACHINES.
- MAX. LENGTH FOR VENDING MACHINE: 3.0 METERS.

RELATED DOCUMENTS		3RD ANGLE PROJECTION		THIS DRAWING IS CONFIDENTIAL AND THE PROPERTY OF TURCK INC. USE OF THIS DOCUMENT WITHOUT WRITTEN PERMISSION IS PROHIBITED.		3000 CAMPUS DRIVE MINNEAPOLIS, MN 55441 1-800-544-7769 (763) 553-7300 (763) 553-0708 fax www.turck.us	
1.				DRFT *CK		DATE 07/19/10	
2.				APVD		SCALE 1=1.0	
3.		ALL DIMENSIONS DISPLAYED ON THIS DRAWING ARE FOR REFERENCE ONLY		UNIT OF MEASUREMENT		DESCRIPTION	
4.				MILLIMETER [INCH]		PKW 3M-*/S90/SV	
MATERIAL		CONTACT TURCK FOR MORE INFORMATION		IDENTIFICATION NO.		REV	
FINISH				DO NOT SCALE THIS DRAWING		E	
E UPDATE CABLE OD		CK 08/10/11 35981		FILE: 777017123		SHEET 1 OF 1	
REV DESCRIPTION		BY DATE ECO NO.					