

FEMALE END VIEW

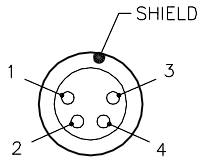

- 1 = BROWN
- 2 = WHITE
- 3 = BLUE
- 4 = BLACK



SPECIFICATIONS

CONTACT CARRIER MATERIAL/COLOR	NYLON OR TPU/BLACK
MOLDED HEAD MATERIAL/COLOR	TPU/YELLOW
CONTACT MATERIAL/PLATING	BRASS/GOLD
COUPLING NUT MATERIAL/PLATING	BRASS/NICKEL
RATED CURRENT [A]	2.0 A
RATED VOLTAGE [V]	125 VAC/VDC
OUTER JACKET MATERIAL/COLOR	TPU/BLACK
CONDUCTOR INSULATION MATERIAL	PVC
NUMBER OF CONDUCTORS [AWG]	4x26 AWG
DRAIN/SHIELD	26 AWG/ALUM.-POLYESTER FOIL, T-C BRAID
TEMPERATURE RANGE	-40°C to +90°C (-40°F to +194°F)
PROTECTION CLASS	MEETS IEC IP67

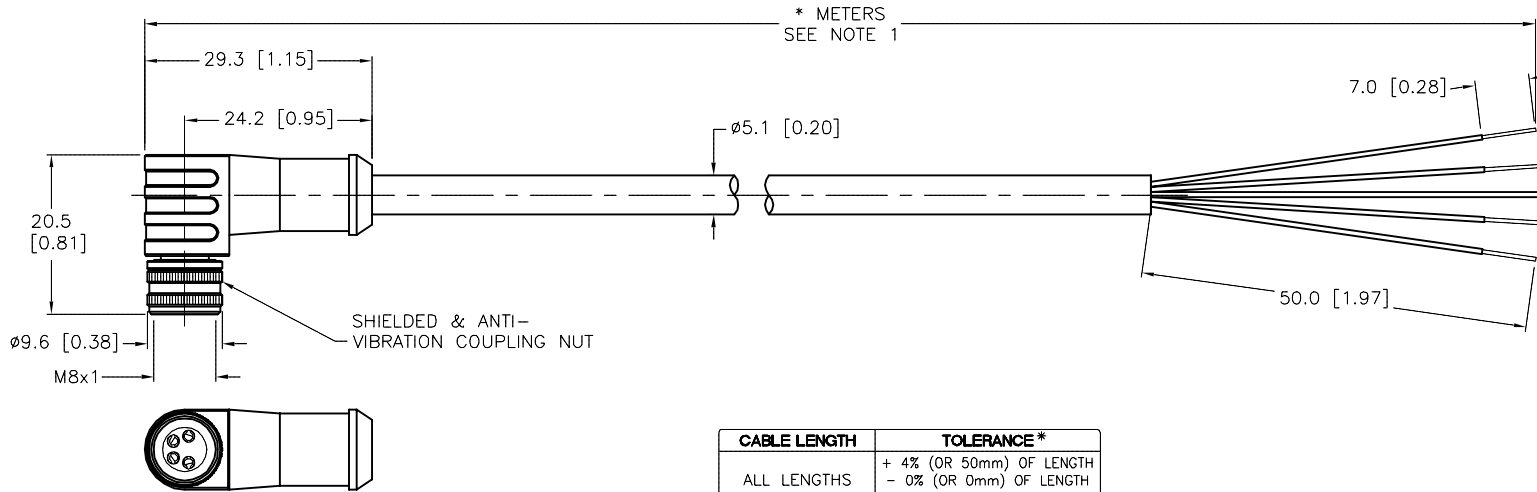

CABLE LENGTH	TOLERANCE*
ALL LENGTHS	+ 4% (OR 50mm) OF LENGTH - 0% (OR 0mm) OF LENGTH WHICHEVER IS GREATER
STRIP LENGTH	TOLERANCE*
0-7mm	±0.5mm
8-29mm	±1.0mm
30-49mm	±2.0mm
50-69mm	±3.0mm
70-100mm	±4.0mm
OVER 100mm	±5.0mm

* UNLESS OTHERWISE SPECIFIED

SOURCE DRAWING - FOR REFERENCE ONLY

NOTES:

- "*" INDICATES CABLE LENGTH IN METERS. CONTACT TURCK TO ORDER SPECIFIC LENGTHS.
- "/S90" DESIGNATES THERMOPLASTIC POLYURETHANE (TPU) CABLE JACKET.

RELATED DOCUMENTS		3RD ANGLE PROJECTION		THIS DRAWING IS CONFIDENTIAL AND THE PROPERTY OF TURCK INC. USE OF THIS DOCUMENT WITHOUT WRITTEN PERMISSION IS PROHIBITED.		TURCK INC High Technology Sensors and Automation Controls 3000 CAMPUS DRIVE MINNEAPOLIS, MN 55441 1-800-544-7769 (763) 553-7300 (763) 553-0708 fax turck.com	
1. 2. 3. 4.				DRFT RDS	DATE 04/08/08	DESCRIPTION PKWS 4M-*/S90	
MATERIAL SEE SPECIFICATIONS		ALL DIMENSIONS DISPLAYED ON THIS DRAWING ARE FOR REFERENCE ONLY		DSGN	SCALE 1=1.0	IDENTIFICATION NO.	
FINISH SEE SPECIFICATIONS		CONTACT TURCK FOR MORE INFORMATION		UNIT OF MEASUREMENT MILLIMETER [INCH]		REV E	
E	UPDATE CURRENT RATING, SEE ECO	RDS	02/16/11	34290	DO NOT SCALE THIS DRAWING		FILE: 777016236
REV	DESCRIPTION	BY	DATE	ECO NO.	SHEET 1 OF 1		