

SPECIFICATIONS	
CONTACT CARRIER MATERIAL	NYLON OR TPU
CONTACT MATERIAL/PLATING	BRASS/GOLD
HOUSING/LOCKNUT MATERIAL/FINISH	STAINLESS STEEL/PASSIVATED
O-RING MATERIAL	VITON
RATED CURRENT [A]	4.0 A
RATED VOLTAGE [V]	250 V
CONDUCTOR INSULATION MATERIAL	PVC
NUMBER OF CONDUCTORS [AWG]	4x22 AWG
TEMPERATURE RANGE	-40°C to +105°C (-40°F to +221°F)
PROTECTION CLASS	MEETS NEMA 1,3,4,6P AND IEC IP68
MAX. PANEL THICKNESS	3.0 [0.12]

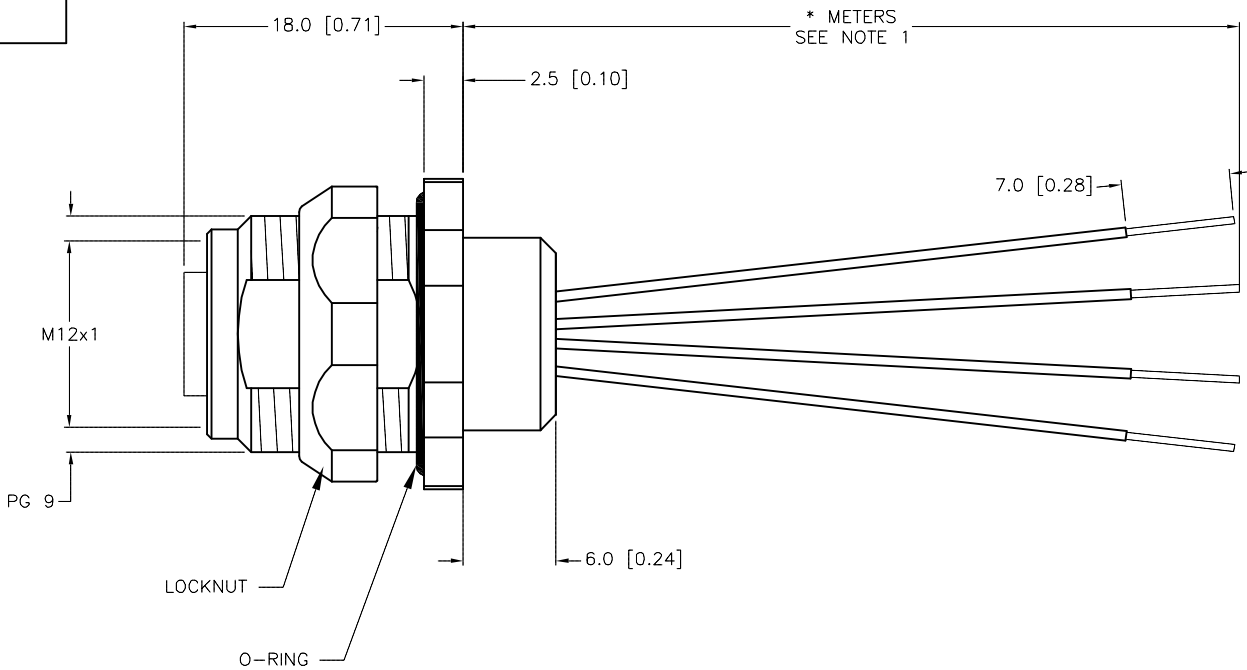
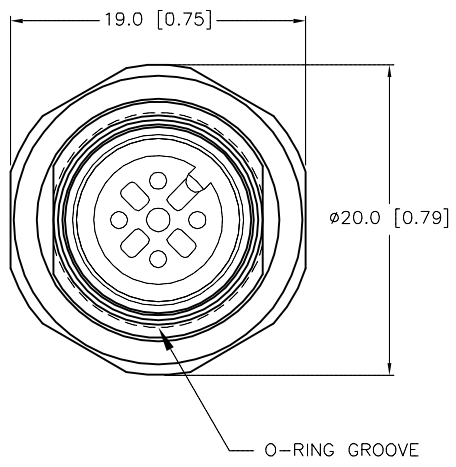

CABLE LENGTH	TOLERANCE*
ALL LENGTHS	+ 4% (OR 50mm) OF LENGTH - 0% (OR 0mm) OF LENGTH WHICHEVER IS GREATER
STRIP LENGTH	TOLERANCE*
0-7mm	±0.5mm
8-29mm	±1.0mm
30-49mm	±2.0mm
50-69mm	±3.0mm
70-100mm	±4.0mm
OVER 100mm	±5.0mm

* UNLESS OTHERWISE SPECIFIED

- NOTES:
- "*" INDICATES LEAD LENGTH IN METERS. CONTACT TURCK TO ORDER SPECIFIC LENGTHS.
 - "/S3039" DESIGNATES RECEPTACLE WITH A VITON O-RING.

SOURCE DRAWING - FOR REFERENCE ONLY

RELATED DOCUMENTS 1. 2. 3. 4.	3RD ANGLE PROJECTION 	THIS DRAWING IS CONFIDENTIAL AND THE PROPERTY OF TURCK INC. USE OF THIS DOCUMENT WITHOUT WRITTEN PERMISSION IS PROHIBITED.		TURCK INC High Technology Sensors and Automation Controls 3000 CAMPUS DRIVE MINNEAPOLIS, MN 55441 1-800-544-7769 (763) 553-7300 (763) 553-0708 fax turck.com		
		DRFT	RWC	DATE	11/29/07	DESCRIPTION FKFDV 4.4-*/S3039
MATERIAL	SEE SPECIFICATIONS	APVD		SCALE	1=.5	
FINISH	SEE SPECIFICATIONS	UNIT OF MEASUREMENT MILLIMETER [INCH]		IDENTIFICATION NO.		REV E
E UPDATE HOUSING NF 02/03/16 53382		CONTACT TURCK FOR MORE INFORMATION		DO NOT SCALE THIS DRAWING		FILE: 777020672
REV DESCRIPTION BY DATE ECO NO.						SHEET 1 OF 1