

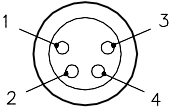



| FEMALE END VIEW | MALE END VIEW | WIRING DIAGRAM | SPECIFICATIONS | | | | | | | | | | | | | | | | | | | | | | | |
|--|---|---|---|--------------------------|--------------|----------------------------|------------|--------------------------|------------|-------------------------------|--------------|-------------------|-------|-------------------|-------------|-----------------------------|------------|-------------------------------|-----|----------------------------|----------|-------------------|-----------------------------------|------------------|----------------------------------|--|
|  <p>1 = BROWN 2 = N/C 3 = BLUE 4 = BLACK</p>  |  <p>1 = BROWN 3 = BLUE 4 = BLACK</p>  |  | <table border="1"> <tr><td>CONTACT CARRIER MATERIAL</td><td>NYLON OR TPU</td></tr> <tr><td>MOLDED HEAD MATERIAL/COLOR</td><td>TPU/YELLOW</td></tr> <tr><td>CONTACT MATERIAL/PLATING</td><td>BRASS/GOLD</td></tr> <tr><td>COUPLING NUT MATERIAL/PLATING</td><td>BRASS/NICKEL</td></tr> <tr><td>RATED CURRENT [A]</td><td>2.0 A</td></tr> <tr><td>RATED VOLTAGE [V]</td><td>125 VAC/VDC</td></tr> <tr><td>OUTER JACKET MATERIAL/COLOR</td><td>PVC/YELLOW</td></tr> <tr><td>CONDUCTOR INSULATION MATERIAL</td><td>PVC</td></tr> <tr><td>NUMBER OF CONDUCTORS [AWG]</td><td>3x24 AWG</td></tr> <tr><td>TEMPERATURE RANGE</td><td>-40°C to +105°C (-40°F to +221°F)</td></tr> <tr><td>PROTECTION CLASS</td><td>MEETS NEMA 1,3,4,6P AND IEC IP67</td></tr> </table> | CONTACT CARRIER MATERIAL | NYLON OR TPU | MOLDED HEAD MATERIAL/COLOR | TPU/YELLOW | CONTACT MATERIAL/PLATING | BRASS/GOLD | COUPLING NUT MATERIAL/PLATING | BRASS/NICKEL | RATED CURRENT [A] | 2.0 A | RATED VOLTAGE [V] | 125 VAC/VDC | OUTER JACKET MATERIAL/COLOR | PVC/YELLOW | CONDUCTOR INSULATION MATERIAL | PVC | NUMBER OF CONDUCTORS [AWG] | 3x24 AWG | TEMPERATURE RANGE | -40°C to +105°C (-40°F to +221°F) | PROTECTION CLASS | MEETS NEMA 1,3,4,6P AND IEC IP67 | |
| CONTACT CARRIER MATERIAL | NYLON OR TPU | | | | | | | | | | | | | | | | | | | | | | | | | |
| MOLDED HEAD MATERIAL/COLOR | TPU/YELLOW | | | | | | | | | | | | | | | | | | | | | | | | | |
| CONTACT MATERIAL/PLATING | BRASS/GOLD | | | | | | | | | | | | | | | | | | | | | | | | | |
| COUPLING NUT MATERIAL/PLATING | BRASS/NICKEL | | | | | | | | | | | | | | | | | | | | | | | | | |
| RATED CURRENT [A] | 2.0 A | | | | | | | | | | | | | | | | | | | | | | | | | |
| RATED VOLTAGE [V] | 125 VAC/VDC | | | | | | | | | | | | | | | | | | | | | | | | | |
| OUTER JACKET MATERIAL/COLOR | PVC/YELLOW | | | | | | | | | | | | | | | | | | | | | | | | | |
| CONDUCTOR INSULATION MATERIAL | PVC | | | | | | | | | | | | | | | | | | | | | | | | | |
| NUMBER OF CONDUCTORS [AWG] | 3x24 AWG | | | | | | | | | | | | | | | | | | | | | | | | | |
| TEMPERATURE RANGE | -40°C to +105°C (-40°F to +221°F) | | | | | | | | | | | | | | | | | | | | | | | | | |
| PROTECTION CLASS | MEETS NEMA 1,3,4,6P AND IEC IP67 | | | | | | | | | | | | | | | | | | | | | | | | | |

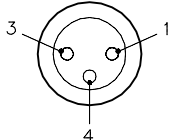

| CABLE LENGTH | TOLERANCE* |
|--------------|---|
| ALL LENGTHS | + 4% (OR 50mm) OF LENGTH - 0% (OR 0mm) OF LENGTH WHICHEVER IS GREATER |
| STRIP LENGTH | TOLERANCE* |
| 0-7mm | ±0.5mm |
| 8-29mm | ±1.0mm |
| 30-49mm | ±2.0mm |
| 50-69mm | ±3.0mm |
| 70-100mm | ±4.0mm |
| OVER 100mm | ±5.0mm |

* UNLESS OTHERWISE SPECIFIED

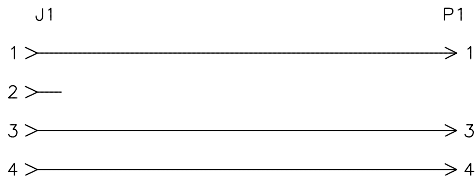
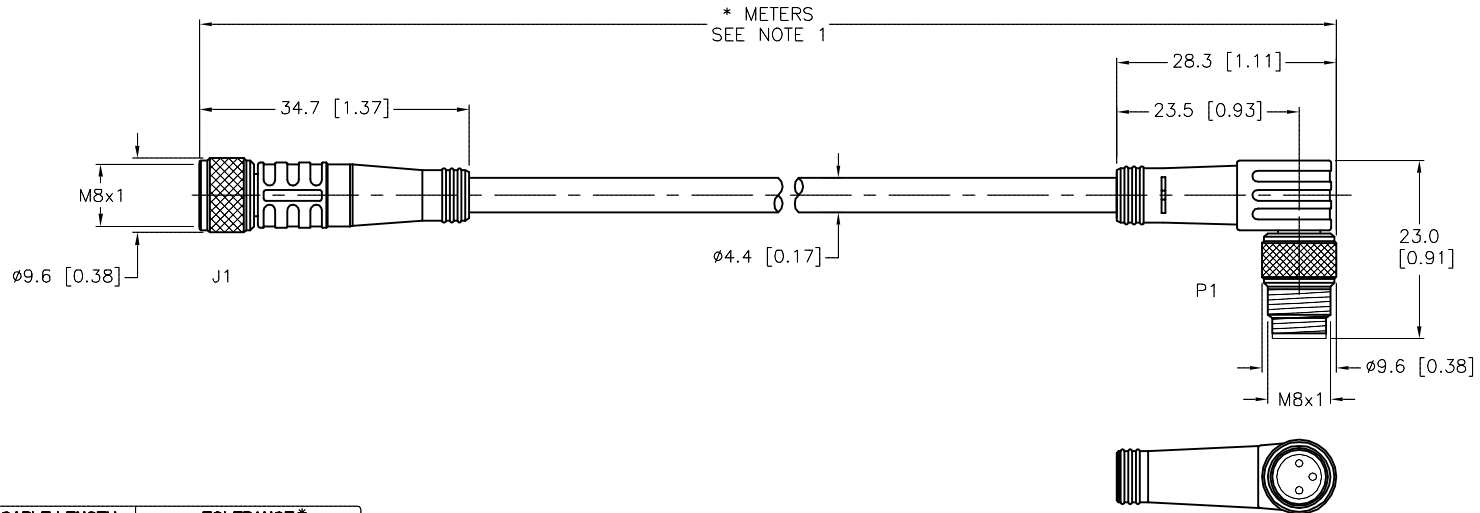
NOTES:

1. "*" INDICATES CABLE LENGTH IN METERS. CONTACT TURCK TO ORDER SPECIFIC LENGTHS.

SOURCE DRAWING - FOR REFERENCE ONLY

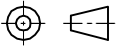
| RELATED DOCUMENTS | | 3RD ANGLE PROJECTION | | THIS DRAWING IS CONFIDENTIAL AND THE PROPERTY OF TURCK INC. USE OF THIS DOCUMENT WITHOUT WRITTEN PERMISSION IS PROHIBITED. | |  High Technology Sensors and Automation Controls 3000 CAMPUS DRIVE MINNEAPOLIS, MN 55441 1-800-544-7769 (763) 553-7300 (763) 553-0708 fax turck.com | |
|-------------------|--------------------|---|---------------------------|--|--------------------|---|-----|
| 1. | |  | DRFT | TR | DATE | 04/03/09 | |
| 2. | | | APVD | | SCALE | 1=1.0 | |
| 3. | | ALL DIMENSIONS DISPLAYED ON THIS DRAWING ARE FOR REFERENCE ONLY | UNIT OF MEASUREMENT | | DESCRIPTION | | |
| 4. | | | MILLIMETER [INCH] | | PKG 4M-*--PSW 3M | | |
| MATERIAL | SEE SPECIFICATIONS | CONTACT TURCK FOR MORE INFORMATION | DO NOT SCALE THIS DRAWING | | IDENTIFICATION NO. | | REV |
| FINISH | SEE SPECIFICATIONS | | | | | | E |
| | | | | FILE: 777008264 | | SHEET 1 OF 1 | |

| | | | | |
|-----|-------------------|-----|----------|---------|
| E | UPDATE CABLE USED | RDS | 02/12/14 | 44746 |
| REV | DESCRIPTION | BY | DATE | ECO NO. |