

FEATURES

- Designed for fixed gas detection systems
- Diffused gas sampling
- Accessories available
- Rugged construction
- LEL and % volume monitoring
- Three thread options available
- ATEX certified  II 2G Ex d IIC T5 Gb
(T_a = -20 to +60 °C)
- CSA certified - File 107498

DESCRIPTION

The VQ600 Series is designed to detect and monitor various gases in the range 0 to 100% LEL for combustible gases and 0 to 100% volume in thermal conductivity mode when using the SGX Sensortech range of pellistor gas sensors.

The VQ600 Series is designed for use as an integral part of a fixed gas detection system. The head comprises a stainless steel flameproof enclosure constructed with an integral stainless steel sinter which allows the safe entry of the atmosphere being tested.

There are three types of mounting thread available to allow easy fixing to the junction box of the fixed system and the facility to attach accessories to the sensor via an external M46 thread.

Other benefits of the VQ600 Series are:

- No moving parts.
- No serviceable parts.
- No adjustments required.
- No assembly or dismantling.

The VQ600 Series operates from 0 to 100% non-condensing relative humidity and in a temperature range of -20 to +60 °C.

Note that there are no serviceable or adjustable parts within the sensor assembly and any attempt to dismantle the assembly or access the sensor will invalidate the sensor approvals and manufacturer's guarantee.

OPERATION

The pellistor used in the head should be operated in the manner recommended in the appropriate data sheet. In general it is recommended that the detector and compensator be run in a Wheatstone Bridge circuit so that a difference signal may be obtained. A suitable circuit is shown in Fig. 1 overleaf.

In use, the bridge supply voltage should not be allowed to vary by more than the specified +0.1 V, or the output in clean air may change in sympathy.



Although SGX Sensortech generally recommends that pellistors should be run with a constant voltage supply to the bridge, it is possible to use a constant current supply provided that the voltage across the bridge in clean air remains within the recommended limits.

The head must be mounted so that the cable is protected. This is normally achieved by mounting it into a port in a suitable junction box.

It is essential that the head be efficiently earthed (grounded). This may be achieved by mounting it either into an earthed metal junction box, or into a non-metallic junction box fitted with an earth continuity plate used in accordance with the box manufacturer's instructions. There are no internal connections to the sensing head body.

CERTIFICATIONS

The VQ600 Series is certified by SIRA Certification Services, EU Notified Body No. 0518.

Certificate number BAS01ATEX2110X certifies it as flameproof equipment to EN60079-0:2006 (including amendments A1 and A2) and EN60079-1:2007 subject to the Instructions specific to hazardous area installations (see page 2).

The VQ600 Series is certified by CSA International for Class 1, Groups B, C and D hazardous locations for both Canada and the USA.

Certification for Canada is as products in Class 4818 03 to the requirements of CSA Standards C22.2 No. 30-M1986 and C22.2 No. 142-M1987 and is covered by File No. LR107498.

Instructions

Instructions specific to hazardous area installations (reference ATEX Directive 94/9/EC, Annex II, 1.0.6).

1. The head is classified as flameproof equipment and is marked:

BAS01ATEX2110X
 II 2G Ex d IIC T5 Gb
 $T_a = -20\text{ }^\circ\text{C to } +60\text{ }^\circ\text{C}$
 2 W/5 V MAX

The head should only be used within the limits imposed by this certification and by these conditions of use.

2. The head may be used in a hazardous area without further mechanical protection. However, the cable requires mechanical protection and must be terminated in a suitable enclosure.
3. The head must be efficiently earthed (grounded). This may be achieved by mounting it into an appropriate earthed metal junction box or into a non-metallic junction box fitted with an earth continuity plate used in accordance with the box manufacturer's instructions. There are no internal connections to the sensing head body.
4. In the event that the head becomes embedded in a junction box by over-tightening or corrosion, it may be released by the use of a spanner or wrench on the two flat surfaces on the sides of the body.
5. There are no user serviceable parts inside the body of the sensing head, and no attempt should be made to open the body for any purpose. The unit is non-repairable.
6. The head has not been assessed as a safety device (EHSR 1.5).
7. When installed in outdoor locations where rain or spray could interfere with the safe working of the head, or in indoor locations where water jets, sprays, or hoses are used routinely for cleaning purposes, the head should be fitted with the Weather Cap that is available as an accessory.
8. The end-user/installer should be aware that the certification of the head relies in its construction on the use of the following materials, which are suitable for most common applications:

Enclosure	Stainless Steel
Sinter	Stainless Steel
Bushing	Epoxy resin

In accordance with the Note in EN60079-0:2006 Clause 6.1(a), the end-user/installer shall inform the manufacturer of any adverse conditions that the head may encounter. This is to ensure that the head is not subject to conditions that may cause degradation of these materials.

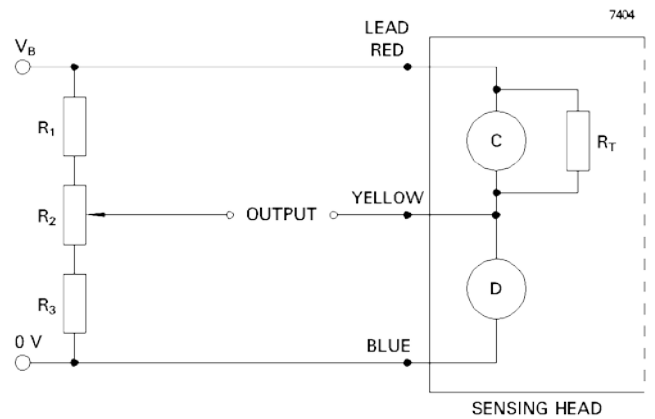

$R_1 = R_3 = 500 \text{ to } 5000\ \Omega$, $R_2 \cong R_1/5$

R_2 provides zero adjustment and may be omitted if not required.

Fig. 1: Recommended circuit diagram

HEALTH AND SAFETY HAZARDS

This device contains PTFE. If it is subjected to temperatures above $350\text{ }^\circ\text{C}$, there is a danger from the release of toxic fumes and breakdown products. Do not dispose of by incineration.

TABLE 1

Typical operating characteristics at room temperature when fitted with SGX's most widely used pellistors.

Pellistor	Bridge voltage (V)	Zero offset range (mV)	Minimum sensitivity in methane (mV/%)
VQ1	2.0	-25 to +35	14
VQ3	2.5	-25 to +25	17
VQ10 and VQ10S	2.0	+35 to +55	9
VQ21T (poison resistant)	2.0	-15 to +30	10
VQ24 and VQ24S	3.5	0 to +50	21

For more detailed performance specifications for the VQ600, please refer to the corresponding SGX Sensortech data sheet for the pellistor sensor fitted.

ACCESSORIES

(All dimensions in millimetres)

Three accessories are available to complement the VQ600 Series gas detection head. These accessories are shown on page 3, with the VQ600 in place.

Flow Cap DAS546633AA

7847

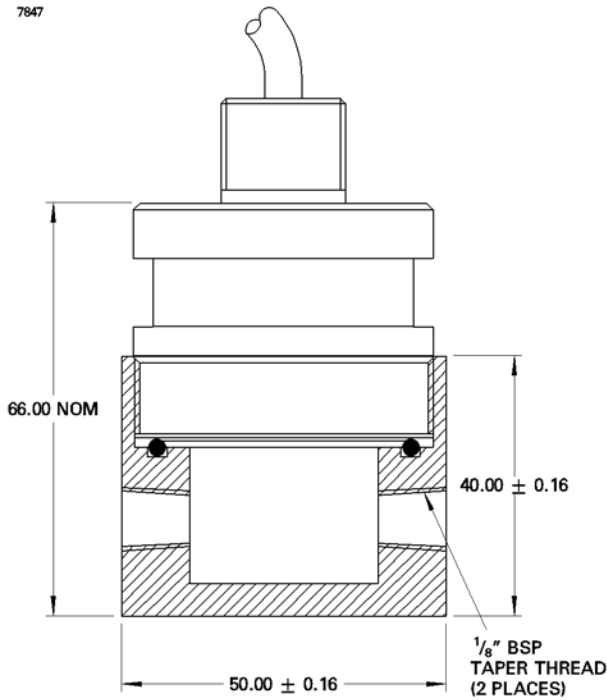

The Flow Cap allows the VQ600 to be used in applications where it is to be aspirated permanently with a pumped or pressurised sample. The cap is made of 316 stainless steel and can be used in a variety of applications involving pumped sampling analysis or detection systems.

Weather Cap DAS546632AA

7848

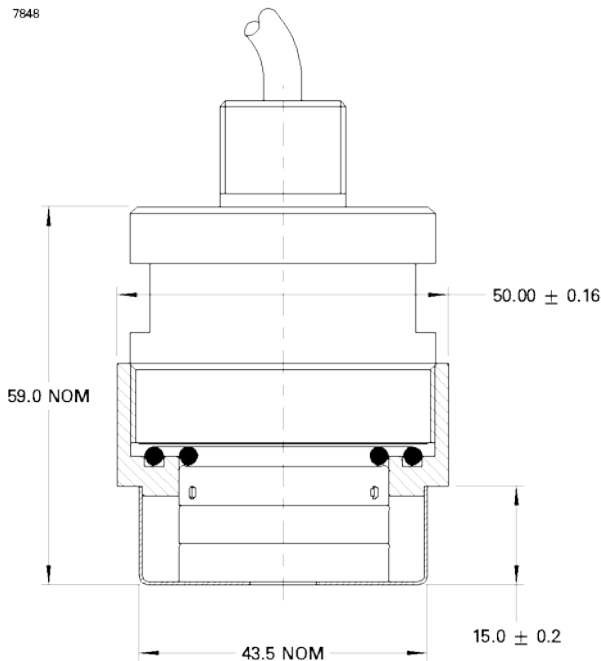

The Weather Cap protects the VQ600 from water when used in external locations, where rain or spray could interfere with the safe working of the head, or in internal locations where water jets, sprays or hoses are used routinely for cleaning purposes, etc. The cap is made of 316 stainless steel and has been tested to IP64 for effectiveness, and also to ensure that it does not significantly affect the VQ600's performance.

Quick Calibration Hood DPP546618DA

7850

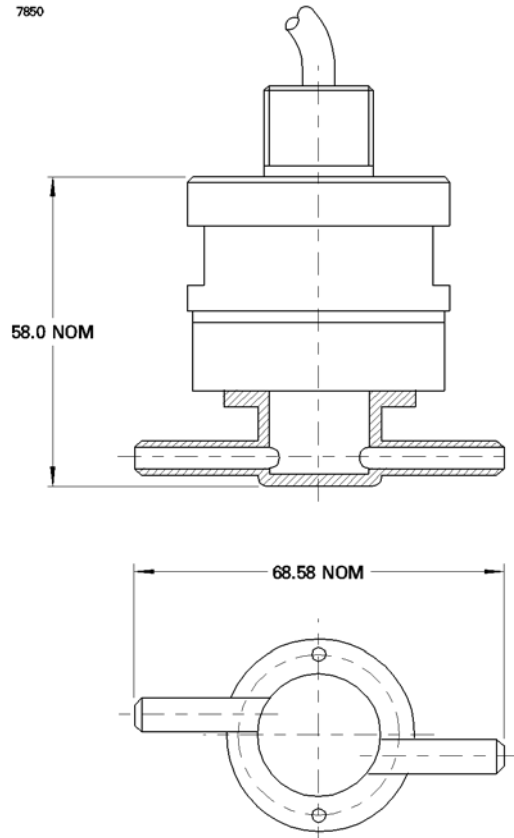

The Quick Calibration Hood is constructed from polypropylene, and provides a convenient means of supplying test gases to the VQ600 in the field, for calibration and checking purposes. The assembly push-fits into the central gas access recess of the head, and is designed to accommodate 6 mm ID or 1/4" flexible tubing.

ORDERING DETAILS

Sensing heads should be ordered by the full part number

VQ6xxyy/z

where:

- xx = the numeric part of the part number of the pellistor fitted, with leading zero where appropriate;
- yy = the alpha part of the part number of the pellistor fitted, but omitting any letter, such as B, which defines the leg type of the pellistor;
- z = a code defining the cap thread (see Mounting Options).

Examples

VQ621T/1

VQ600 series head fitted with VQ21T pellistor and supplied with 20 x 1.5 mm metric thread cap.

VQ603/2

VQ600 series head fitted with VQ3 pellistor and supplied with 1/2" - 14 NPT American National Pipe Taper thread.

OUTLINE OF VQ600 SERIES

(All dimensions in millimetres; dimensions without limits are nominal)

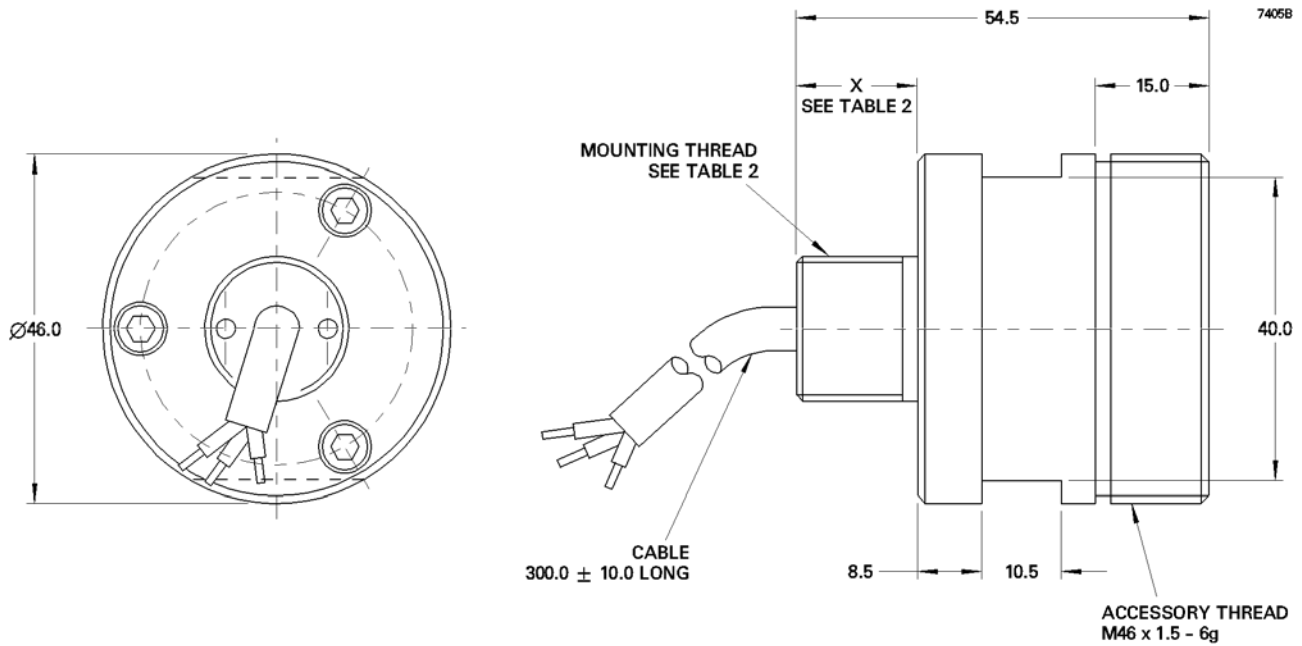

Lead Colour	Element
Blue	Detector
Red	Compensator
Yellow	Common

Table 2 - Mounting Options

The sensing head is supplied with one of three different mounting threads at the user's choice (see outline).

Thread	Thread code	Dimension X (mm)
Metric 20 x 1.5 mm	1	16.00
ANP (Taper) 1/2" - 14 NPT	2	19.85
ANP (Taper) 3/4" - 14 NPT	3	20.16

Taper threads are manufactured in accordance with ANSI/ASME B1.20.1.