

TARS-B SERIES

000862

Issue 1

Transportation Attitude Reference System Ruggedized Inertial Measurement Unit (IMU)

DESCRIPTION

The Transportation Attitude Reference System (TARS-IMU) is a packaged sensor array designed to report vehicle angular rate, acceleration, and attitude data for demanding applications in industries such as heavy-duty, off-highway transportation.

The TARS-IMU enables autonomous vehicle characteristics and enhances efficiency and productivity by reporting key data required to automate and monitor movements of vehicle systems and components. The sensor fusion algorithm may be customized for specific vehicle applications via on-board firmware, allowing movement data to be filtered for extraneous environment and vehicle movements.

With a wide operating voltage, the TARS-IMU can accommodate 9 V to 36 V vehicle power systems. Communication is transmitted using industry standard CAN J1939 connectivity. As a standard, TARS-IMU is calibrated on aerospace-grade rate tables at the factory to provide enhanced calibration consistency between units.

Customization

The TARS-IMU may be customized to best meet application needs using the TARS Configurator Tool (TCT) software to change selected parameters such as independently variable message broadcast rates, orientation, filter settings, etc. This tool creates a unique configuration file which is then uploaded to the TARS-IMU for implementation.

DIFFERENTIATION

- **Flexible.** On-board firmware customizes the TARS-IMU to the specific vehicle for its designed application.
- **Durable.** With top-of-the-line sealing (IP67, IP69K), the TARS-IMU is ruggedized to withstand harsh or heavy-duty applications.
- **Convenient.** The TARS-IMU is delivered with customizable firmware that allows manufacturers to use a single part number across vehicles and applications. If preferred, the TARS-IMU may be pre-configured at the Honeywell factory for immediate installation out of the box.

VALUE TO CUSTOMERS

- Designed to allow vehicle manufacturers and end users to increase efficiency with the automation of repetitive movements and complex tasks
- Enables precise movement, actuation, and guidance over severe terrain and vehicle grades
- Enhances safety through monitoring and guidance capabilities to promote the productivity of operators

POTENTIAL APPLICATIONS

- Equipment control
- Linkage tracking
- Bucket control
- Work monitoring
- Vehicle stability control
- Operator assisted control
- Performance and output control
- Linear position



FEATURES

- High performance IMU reports vehicle angular rate, acceleration and inclination data (6 degrees of freedom, see Figure 1)
- Ruggedized PBT thermoplastic housing design for many demanding applications and environments (IP67 and IP69K certified)
- Advanced filtering of raw sensor data to minimize unwanted noise and vibration promotes positioning accuracy
- Supports 9 V to 36 V vehicle power systems
- Operating temperature of -40°C to 85°C [-40°F to 185°F]
- Customizable via TCT software available on the web
- Reduced power consumption
- Small form-factor
- Optional metal guard for added protection (TARS-SHIELD)

PORTFOLIO



The TARS-B Series joins Honeywell's venerated sensor portfolio, adding to the ever-increasing connected and intelligence-driven capabilities that Honeywell offers. TARS-IMU is built to withstand the demanding applications in industries like off-highway transportation and beyond.

Honeywell

TRANSPORTATION ATTITUDE REFERENCE SYSTEM TARS-B SERIES

FIGURE 1. SIX DEGREES OF FREEDOM

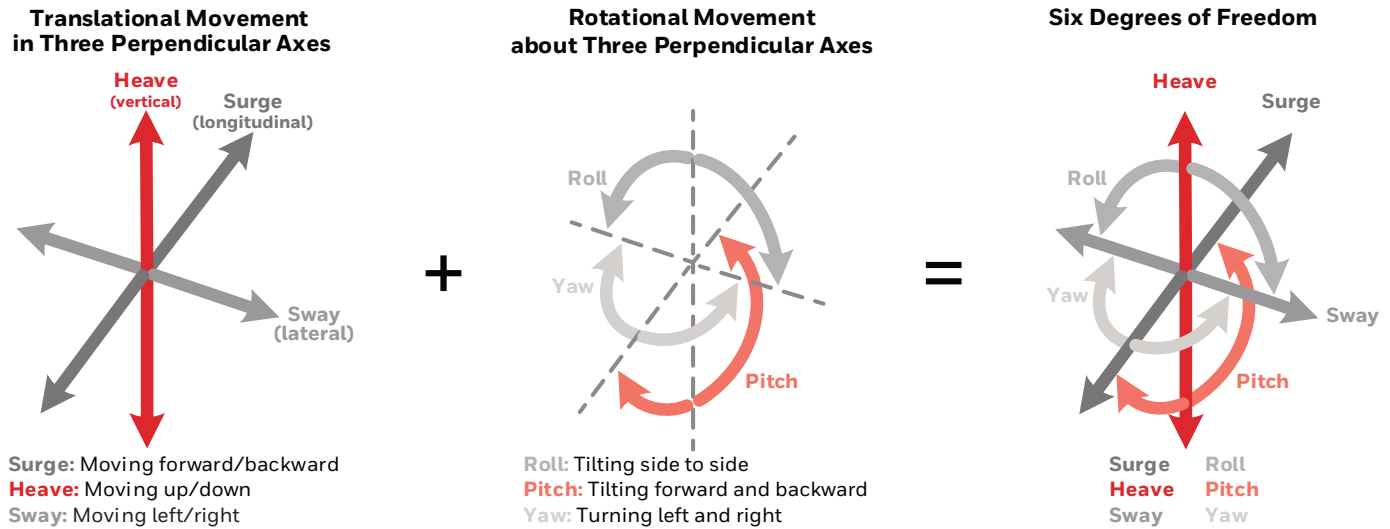

TABLE 1. SENSOR SPECIFICATIONS

Characteristic	Parameter
Gyroscope 3 axis performance	
Range	±500 deg/s
Resolution	7.81 mdps
In-run bias stability	3.8 deg/hr
Noise density	14 mdps/√Hz
Offset (0°C to 50°C)	±0.5 deg/s
Offset (-40°C to 85°C)	±1.1 deg/s
Accelerometer 3 axis performance	
Range	±58.84 m/s ²
Resolution	0.01 m/s ²
In-run bias stability	30 μg
Noise density	92 μg/√Hz
Offset (0°C to 50°C)	±0.04 m/s ²
Offset (-40°C to 85°C)	±0.06 m/s ²
Inclination (pitch and roll)	
Range (roll/pitch)	±180/±90 deg
Resolution	0.01 deg
Static error (0°C to 50°C)	±0.3 deg
Static error (-40°C to 85°C)	±0.5 deg
Translational acceleration error	±0.3 deg
Centripetal acceleration error	±0.3 deg

TRANSPORTATION ATTITUDE REFERENCE SYSTEM

TARS-B SERIES

TABLE 2. ELECTRICAL SPECIFICATIONS

Characteristic	Min.	Typ.	Max.	Unit
Supply voltage	9	12/24	36	V
Supply current	–	–	100	mA
Reverse voltage	–	–	-36	V
Overvoltage	–	–	36	V
Start-up time	500	–	2000	ms
Short circuit protection	ISO 16750-2: 2012 – CAN output shorted to supply voltage or ground without damage			
Open circuit protection	ISO 16750-2: 2012 – Single-line and multiple-line interruption			
Power interruption	ISO 11783-5: 2009 – 10 ms interruption, 100 ms apart; no resets or loss of data in volatile memory			
Reset response	ISO 16750-2: 2012 – Automatic recovery after voltage dropout			
Power line test pulse 1	ISO 7637-2: 2004 AMD1: 2008 / 12 V and 24 V system			
Power line test pulse 2a	ISO 7637-2: 2004 AMD1: 2008 / 12 V and 24 V system			
Power line test pulse 2b	ISO 7637-2: 2004 AMD1: 2008 / 12 V and 24 V system			
Power line test pulses 3a and 3b	ISO 7637-2: 2004 AMD1: 2008 / 12 V and 24 V system			
Load dump	ISO 16750-2: 2012 / 12 V and 24 V system			

CAN output characteristics per SAE J1939

Characteristic	Min.	Typ.	Max.	Unit
Baud rate	125	250 ¹	500	kbps
Broadcast rate	–	–	200 ²	Hz

¹ Factory default setting is 250 kbps.

² Factory default setting is 100 Hz.

TABLE 3. ENVIRONMENTAL SPECIFICATIONS¹

Characteristic	Parameter
Operating temperature	-40°C to 85°C [40°F to 185°F]
Storage temperature ²	-40°C to 105°C [40°F to 221°F]
Housing	PBT thermoplastic
Random vibration	9 hours per axis at 16.91 Grms per MIL-STD-202, Method 214, Test Condition I, Letter E, 50 Hz to 2000 Hz
Mechanical shock	50 g 11 ms half-sine, 3 each direction, 18 total, pulse per MIL-STD-202, Method 213
Chemical compatibility	diesel fuel, hydraulic oil, ethylene glycol, motor oil, brake fluid, urea nitrogen, liquid lime, NPK fertilizer, ammonium hydroxide, alkaline degreaser, transmission oil, power steering fluid, and axle oil
Moisture resistance	per MIL-STD-202, Method 106 (10 cycles, 24 hours/cycle)
Thermal shock	250 cycles, -40°C to 85°C, 73 min dwell
Salt spray	5 % salt solution, 96 hours
Ingress protection	IP67, IP69K (DIN40050-1993) with mating connector installed
RoHS	compliant
REACH	compliant
UV rating	housing material meets outdoor suitability requirements per UL746C F1 rating

¹ For environmental conditions not covered by product specifications, consult with Honeywell Engineering.

² In installed condition; otherwise, maximum storage temperature is 85°C [185°F].

TRANSPORTATION ATTITUDE REFERENCE SYSTEM

TARS-B SERIES

TABLE 4. EMC SPECIFICATIONS¹

Characteristic	Standard	Test Level, Frequency
Radiated immunity	ISO 11452-2: 2019	125 V/m, 400 MHz to 2.5 GHz
Bulk current injection	ISO 11452-4: 2011	125 mA, 1 MHz to 400 MHz
Radiated emission	ISO 13766-1: 2018	30 MHz to 1 GHz
I/O line coupled transients	ISO 7637-3: 2016	test pulse a and test pulse b (-80 V, +80 V)
ESD handling	ISO 10605: 2008 AMD1: 2014	direct ±8 kV, air ±15 kV
ESD operational	ISO 10605: 2008 AMD1: 2014	direct ±8 kV, air ±15 kV

¹This product is CE marked according to ISO 14982:1998, ISO 13766-1:2018, and ISO 13766-2:2018.

TABLE 5. INSTALLATION SPECIFICATIONS

Characteristic	Parameter
Mating connector	AMPSEAL 16™ Series: 776487-1 for 18-16 AWG conductors or 776524-1 for 20-18 AWG conductors
CAN termination	120 Ohm termination resistor, not included in TARS-IMU unit
Weight	170 g approx.
Mounting bolt	M8, installation torque 20 Nm ±2 Nm

TABLE 6. ORDER GUIDE

Catalog Listing	Description
TARS-BAASS	TARS-B Series Inertial Measurement Unit, 9 V to 36 V supply voltage, CAN J1939 protocol, AMPSEAL 16™ Series connector

FIGURE 2. PRODUCT NOMENCLATURE

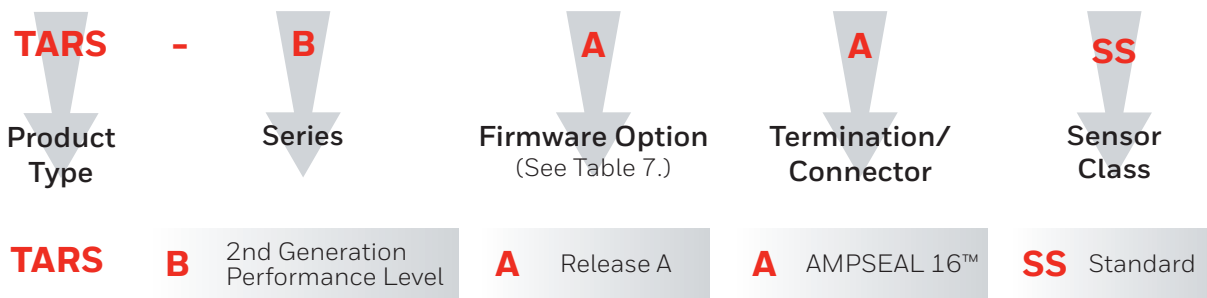

TABLE 7. AVAILABLE BROADCAST MESSAGES AND FUNCTIONS¹

Firmware Option	Accelerations 3 Axes	Angular Rates 3 Axes	Pitch and Roll Angles	Zeroing	Corrected Acceleration
Release A	yes	yes	yes	yes	yes

¹For details regarding the various broadcast messages and functions, refer to the “Installation Instructions for the Transportation Attitude Reference System, TARS-B Series”, document number 3011-2912-001.

TRANSPORTATION ATTITUDE REFERENCE SYSTEM

TARS-B SERIES

FIGURE 3. BODY DIMENSIONS (FOR REFERENCE ONLY: mm [in])

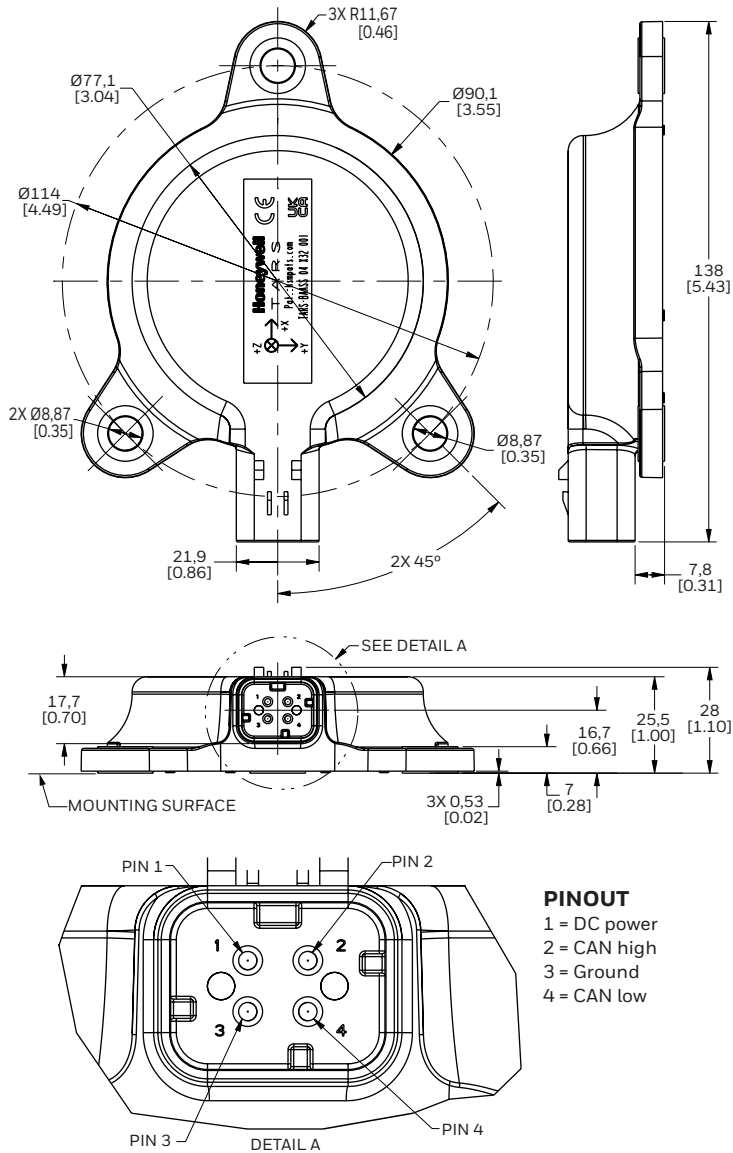
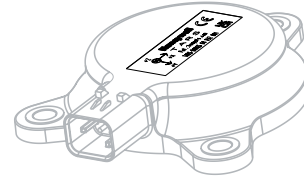

FIGURE 4. MARKING INFORMATION

TOP



04 = Product configuration code (9 - 36V))

X32 = Date code, where:

X = Year code for 2016, **Y** for 2017, **Z** for 2018, **A** for 2019, etc.

32 = Week of final test

001 = Consecutive number, different for each product

BOTTOM

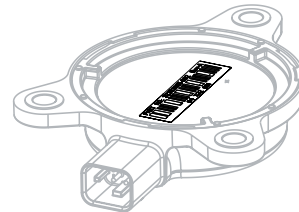

The adhesive label on the the bottom of the sensor indicates the hardware part number and revision. The barcode information is the unique number of the sensor, comprised of the configuration code, the date code and the consecutive number.

For example: **04 X32 001**.

TRANSPORTATION ATTITUDE REFERENCE SYSTEM TARS-B SERIES

FIGURE 5. MOUNTING HOLE DIMENSIONS (FOR REFERENCE ONLY: mm [in])

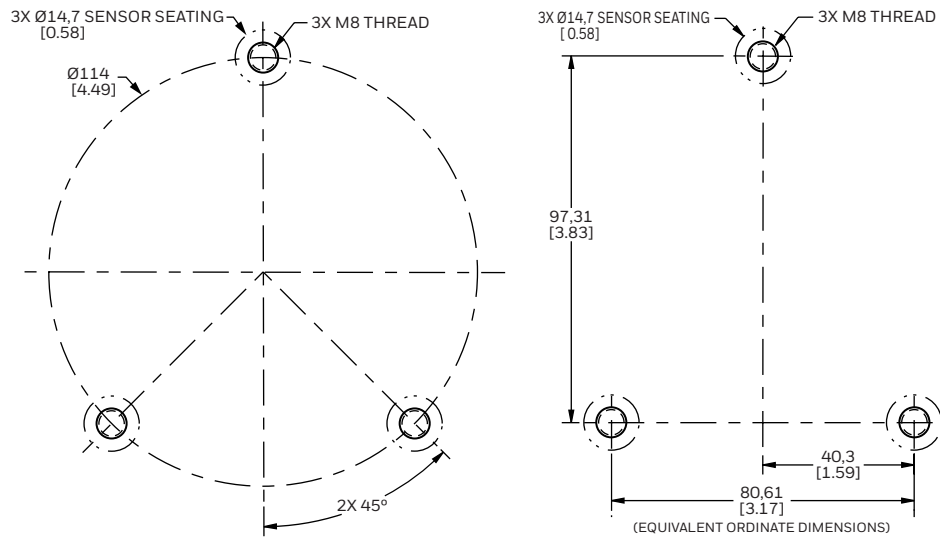

OPTIONAL PROTECTIVE SHIELD

NOTICE

If the the sensor is to be used in direct gravel bombardment, or in any other environment where physical strikes are likely, install a protective shield from Honeywell (see Figure 6 and Table 8) or equivalent over the sensor.

TABLE 8. ORDER GUIDE

Catalog Listing	Description
TARS-SHIELD	Zinc, die-cast protective shield for use with the TARS-B Series.

FIGURE 6. TARS SHIELD DIMENSIONS (FOR REFERENCE ONLY: mm [in])

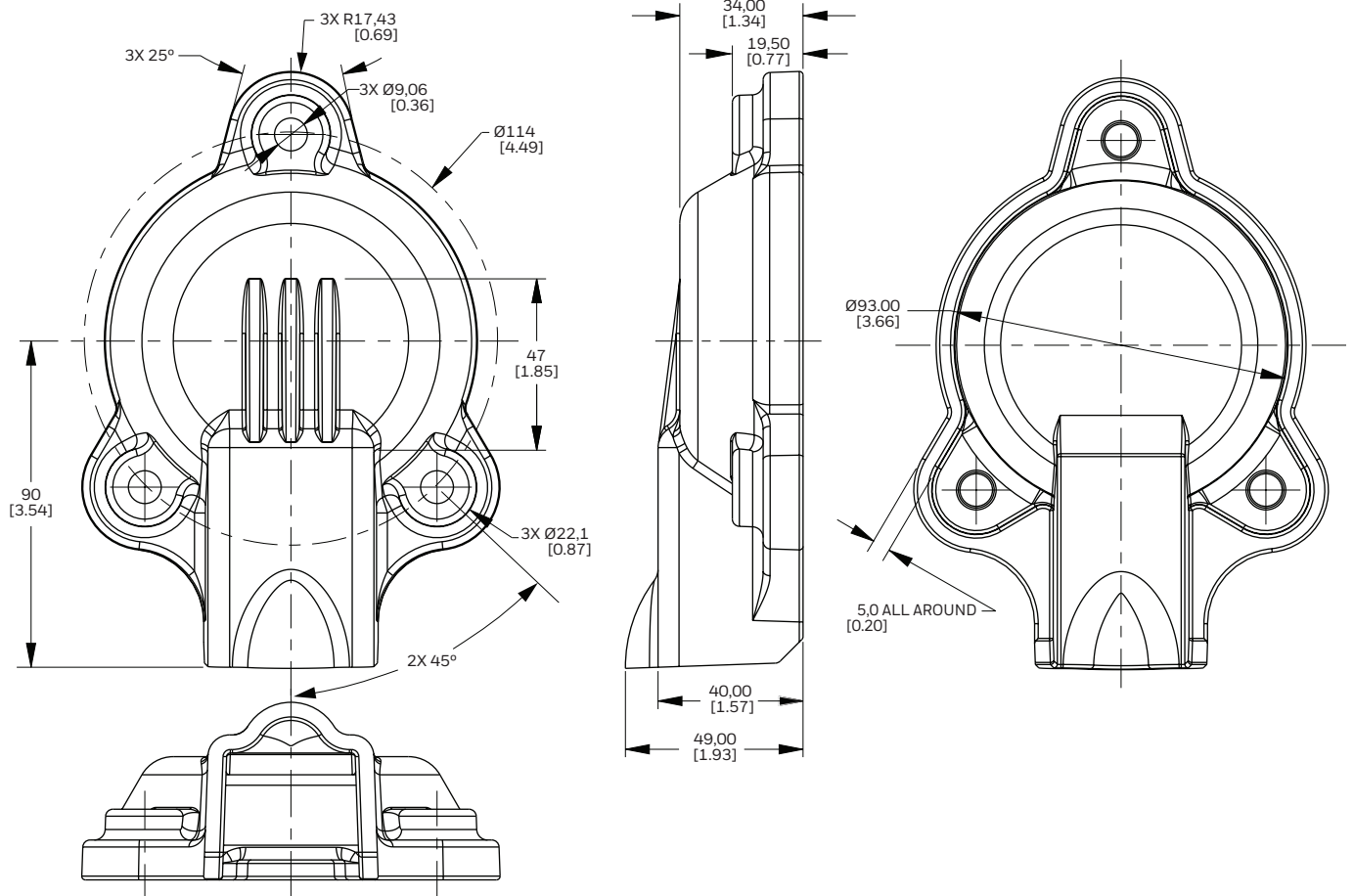

WARRANTY/REMEDY

Honeywell warrants goods of its manufacture as being free of defective materials and faulty workmanship during the applicable warranty period. Honeywell's standard product warranty applies unless agreed to otherwise by Honeywell in writing; please refer to your order acknowledgment or consult your local sales office for specific warranty details. If warranted goods are returned to Honeywell during the period of coverage, Honeywell will repair or replace, at its option, without charge those items that Honeywell, in its sole discretion, finds defective. **The foregoing is buyer's sole remedy and is in lieu of all other warranties, expressed or implied, including those of merchantability and fitness for a particular purpose. In no event shall Honeywell be liable for consequential, special, or indirect damages.**

While Honeywell may provide application assistance personally, through our literature and the Honeywell web site, it is buyer's sole responsibility to determine the suitability of the product in the application.

Specifications may change without notice. The information we supply is believed to be accurate and reliable as of this writing. However, Honeywell assumes no responsibility for its use.

FOR MORE INFORMATION

Honeywell Sensing and Safety Technologies services its customers through a worldwide network of sales offices and distributors. For application assistance, current specifications, pricing or the nearest Authorized Distributor, visit [our website](#) or call:

USA/Canada	+1 302 613 4491
Latin America	+1 305 805 8188
Europe	+44 1344 238258
Japan	+81 (0) 3-6730-7152
Singapore	+65 6355 2828
Greater China	+86 4006396841

Honeywell Sensing and Safety Technologies

830 East Arapaho Road
Richardson, TX 75081
sps.honeywell.com/ast

000862-1-EN | 1 | 09/22
©2022 Honeywell International Inc. All rights reserved.

WARNING PERSONAL INJURY

DO NOT USE these products as safety or emergency stop devices or in any other application where failure of the product could result in personal injury.

Failure to comply with these instructions could result in death or serious injury.

WARNING MISUSE OF DOCUMENTATION

- The information presented in this product sheet is for reference only. Do not use this document as a product installation guide.
- Complete installation, operation, and maintenance information is provided in the instructions supplied with each product.

Failure to comply with these instructions could result in death or serious injury.

Honeywell