

P2BT 108-TF

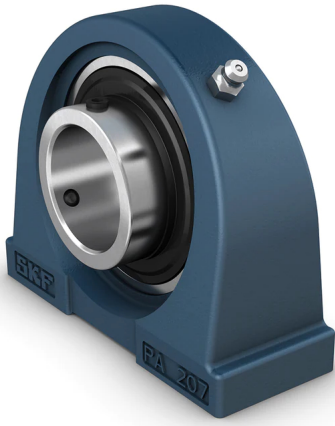

Short base pillow block ball bearing unit with extended inner ring and set screw locking, cast iron, North American standards

Short base pillow (plummer) block ball bearing units consist of an insert bearing mounted in a cast iron housing. This variant has threads for attachment bolts and is suitable for applications with both constant and alternating directions of rotation. It has an inner ring extended on both sides and is locked onto the shaft by tightening a set screw on the inner ring, making it easy to mount.

- Strong
- Ready to mount
- Lubricated and sealed bearing
- Quick locking onto the shaft
- Cost-effective

Overview

Dimensions

Bearing width, total	1.937 in
Centre distance between bolt holes	3.5 in
Centre height (pillow block)	1.937 in
Housing overall width	1.874 in
Shaft diameter	1.5 in

Performance

Basic dynamic load rating	6 902 lbf
Basic static load rating	4 271 lbf
Limiting speed	4 800 r/min
Note	Limiting speed with shaft tolerance h6

Properties

Bore type	Cylindrical
Coating	Without
Fastening bolt hole type	Threaded
Grease fitting	With
Housing type	Pillow block
Lubricant	Grease
Material, bearing	Bearing steel
Material, housing	Cast iron
Number of bolt holes for fasteners	2
Relubrication hole	With

Retaining feature, inner ring	Set screws
Rubber seating ring	Without
Sealing type	Contact, standard
Sealing, bearing	Seal and flinger on both sides
Sealing, unit	Optional end cover

Technical Specification

Compliance with standard	North American standard
Purpose specific	For material handling applications
Material, housing	Cast iron
Sealing, bearing	Seal and flinger on both sides
Sealing type, bearing	Contact, standard
Sealing, unit	Optional end cover
Coating	Without

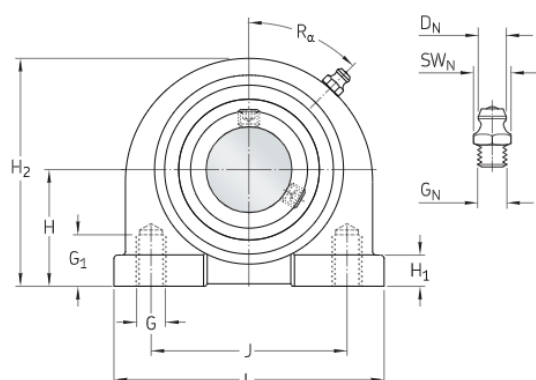
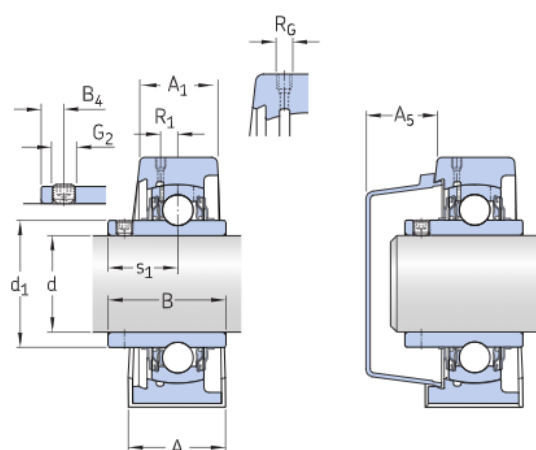

Dimensions

d	1.5 in	Bore diameter
d_1	≈ 2.039 in	Shoulder diameter of inner ring
A	1.874 in	Base width
A_1	1.047 in	Top width
A_5	0.925 in	Standout of end cover
B	1.937 in	Width of inner ring
B_4	0.315 in	Distance from locking device side face to thread centre
H	1.937 in	Height of spherical seat centre
H_1	0.5 in	Foot height
H_2	3.937 in	Overall height
J	3.5 in	Distance between attachment bolts
L	4.626 in	Overall length
s_1	1.189 in	Distance from locking device side face to raceway centre

Threaded hole

R_G 1/8-27 NPT	Housing thread for the grease fitting
R_1 0.106 in	Axial position of the housing thread
R_0 45 °	Angular position of the housing thread

Grease fitting

D_f 0.259 in	Diameter of head sphere of grease fitting
S_f 0.438 in	Hexagonal key size for the grease fitting
G_f 1/8-27 NPT	Thread of grease fitting

Calculation data

Basic dynamic load rating	C	6 902 lbf
Basic static load rating	C_0	4 271 lbf
Fatigue load limit	P_u	180 lbf
Limiting speed		4 800 r/min
		Limiting speed with shaft tolerance h6

Mass

Mass bearing unit	4.189 lb
-------------------	----------

Mounting information

Thread for attachment bolts	G	1/2-13 UNC
Thread length	G_1	0.752 in
Set screw	G_2	5/16-24 UNF
Hexagonal key size for set screw		0.156 in
Recommended tightening torque for set screw		57.53 lbf-in

Included products

Housing	P2BT 508
Bearing	YAR 208-108-2F

Associated products

End cover	ECY 208
-----------	---------

Terms and conditions

By accessing and using this website / app owned and published by AB SKF (publ.) (556007-3495 · Gothenburg) ("SKF"), you agree to the following terms and conditions:

Warranty Disclaimer and Limitation of Liability

Although every care has been taken to assure the accuracy of the information on this website / app, SKF provides this information "AS IS" and DISCLAIMS ALL WARRANTIES, EXPRESS OR IMPLIED, INCLUDING, BUT NOT LIMITED TO, IMPLIED WARRANTIES OF MERCHANTABILITY AND FITNESS FOR A PARTICULAR PURPOSE. You acknowledge that your use of this website / app is at your sole risk, that you assume full responsibility for all costs associated with use of this website / app, and that SKF shall not be liable for any direct, incidental, consequential, or indirect damages of any kind arising out of your access to, or use of the information or software made available on this website / app. Any warranties and representations in this website / app for SKF products or services that you purchase or use will be subject to the agreed upon terms and conditions in the contract for such product or service. Further, for non-SKF websites / apps that are referenced in our website / app or where a hyperlink appears, SKF makes no warranties concerning the accuracy or reliability of the information in these websites / apps and assumes no responsibility for material created or published by third parties contained therein. In addition, SKF does not warrant that this website / app or these other linked websites / apps are free from viruses or other harmful elements.

Copyright

Copyright in this website / app copyright of the information and software made available on this website / app rest with SKF or its licensors. All rights are reserved. All licensed material will reference the licensor that has granted SKF the right to use the material. The information and software made available on this website / app may not be reproduced, duplicated, copied, transferred, distributed, stored, modified, downloaded or otherwise exploited for any commercial use without the prior written approval of SKF. However, it may be reproduced, stored and downloaded for use by individuals without prior written approval of SKF. Under no circumstances may this information or software be supplied to third parties.

This website /app includes certain images used under license from Shutterstock, Inc.

Trademarks and Patents

All trademarks, brand names, and corporate logos displayed on the website / app are the property of SKF or its licensors, and may not be used in any way without prior written approval by SKF. All licensed trademarks published on this website / app reference the licensor that has granted SKF the right to use the trademark. Access to this website / app does not grant to the user any license under any patents owned by or licensed to SKF.

Changes

SKF reserves the right to make changes or additions to this website / app at any time.