

P2BL 207-TF

Pillow block ball bearing unit with extended inner ring and set screw locking, North American standards

Pillow (plummer) block ball bearing units consist of an insert bearing mounted in a cast iron housing that can be bolted to a support surface. This variant is suitable for applications where the direction of rotation is constant or alternating. It has an inner ring extended on both sides and is locked onto the shaft by tightening two set screws on the inner ring, making it easy to mount. The units are compliant with North American standards.

- Low centre height
- Ready to mount
- Lubricated and sealed bearing
- Quick locking onto the shaft
- Extended inner ring for minimized shaft misalignment

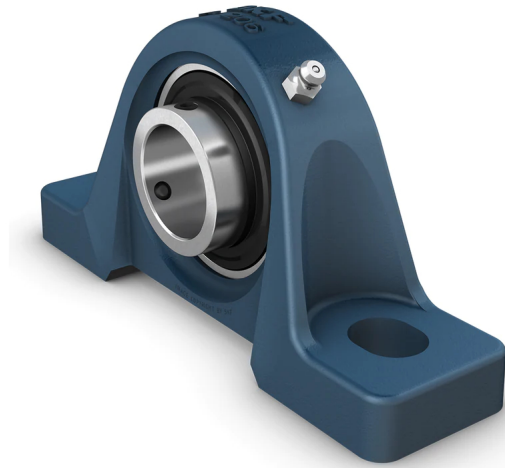

Overview

Dimensions

Bearing width, total	2.563 in
Centre distance between bolt holes	7.407 in
Centre height (pillow block)	2.687 in
Housing overall width	2.425 in
Shaft diameter	2.438 in

Performance

Basic dynamic load rating	11 847 lbf
Basic static load rating	8 093 lbf
Limiting speed	3 400 r/min
Note	Limiting speed with shaft tolerance h6

Properties

Bore type	Cylindrical
Coating	Without
Fastening bolt hole type	Plain
Grease fitting	With
Housing type	Pillow block
Lubricant	Grease
Material, bearing	Bearing steel
Material, housing	Cast iron
Number of bolt holes for fasteners	2
Relubrication hole	With

Retaining feature, inner ring	Set screws
Rubber seating ring	Without
Sealing type	Contact, standard
Sealing, bearing	Seal and flinger on both sides
Sealing, unit	Optional end cover

Technical Specification

Compliance with standard	North American standard
Purpose specific	For material handling applications
Material, housing	Cast iron
Sealing, bearing	Seal and flinger on both sides
Sealing type, bearing	Contact, standard
Sealing, unit	Optional end cover
Coating	Without

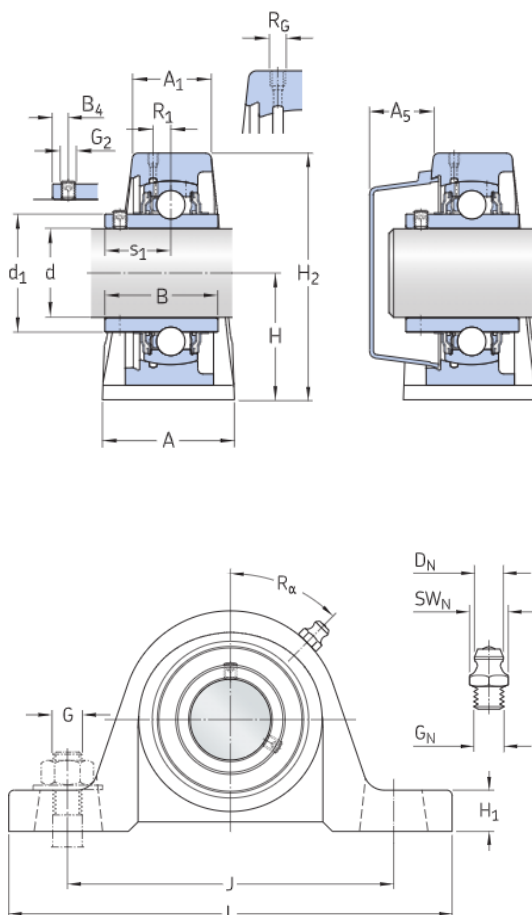

Dimensions

d	2.438 in	Bore diameter
d ₁	≈ 2.978 in	Shoulder diameter of inner ring
A	2.425 in	Base width
A ₁	1.35 in	Top width
A ₅	1.398 in	Standout of end cover
B	2.563 in	Width of inner ring
B ₄	0.394 in	Distance from locking device side face to thread centre
H	2.687 in	Height of spherical seat centre
H ₁	0.813 in	Foot height
H ₂	5.5 in	Overall height
J	7.407 in	Distance between attachment bolts
J	max. 7.939 in	Distance between attachment bolts
J	min. 6.876 in	Distance between attachment bolts
L	9.5 in	Overall length
N	0.781 in	Diameter of attachment bolt hole
N ₁	1.157 in	Length of attachment bolt hole
s ₁	1.563 in	Distance from locking device side face to raceway centre

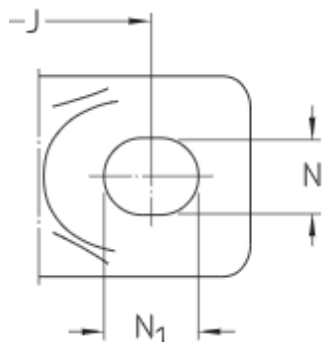

Threaded hole

R_G 1/8-27 NPT	Housing thread for the grease fitting
R_1 0.157 in	Axial position of the housing thread
R_0 45 °	Angular position of the housing thread

Grease fitting

D_f 0.259 in	Diameter of head sphere of grease fitting
S_f 0.438 in	Hexagonal key size for the grease fitting
G_f 1/8-27 NPT	Thread of grease fitting

Calculation data

Basic dynamic load rating	C	11 847 lbf
Basic static load rating	C_0	8 093 lbf
Fatigue load limit	P_u	344 lbf
Limiting speed		3 400 r/min
		Limiting speed with shaft tolerance h6

Mass

Mass bearing unit	9.7 lb
-------------------	--------

Mounting information

Set screw	G_2	3/8-24 UNF
Hexagonal key size for set screw		0.188 in
Recommended tightening torque for set screw		146.037 lbf-in
Recommended diameter for attachment bolts, mm	G	16.002 mm
Recommended diameter for attachment bolts, inch	G	0.625 in

Included products

Housing

P2BL 512

Bearing

YAR 212-207-2F

Associated products

End cover

ECY 212

Terms and conditions

By accessing and using this website / app owned and published by AB SKF (publ.) (556007-3495 · Gothenburg) ("SKF"), you agree to the following terms and conditions:

Warranty Disclaimer and Limitation of Liability

Although every care has been taken to assure the accuracy of the information on this website / app, SKF provides this information "AS IS" and DISCLAIMS ALL WARRANTIES, EXPRESS OR IMPLIED, INCLUDING, BUT NOT LIMITED TO, IMPLIED WARRANTIES OF MERCHANTABILITY AND FITNESS FOR A PARTICULAR PURPOSE. You acknowledge that your use of this website / app is at your sole risk, that you assume full responsibility for all costs associated with use of this website / app, and that SKF shall not be liable for any direct, incidental, consequential, or indirect damages of any kind arising out of your access to, or use of the information or software made available on this website / app. Any warranties and representations in this website / app for SKF products or services that you purchase or use will be subject to the agreed upon terms and conditions in the contract for such product or service. Further, for non-SKF websites / apps that are referenced in our website / app or where a hyperlink appears, SKF makes no warranties concerning the accuracy or reliability of the information in these websites / apps and assumes no responsibility for material created or published by third parties contained therein. In addition, SKF does not warrant that this website / app or these other linked websites / apps are free from viruses or other harmful elements.

Copyright

Copyright in this website / app copyright of the information and software made available on this website / app rest with SKF or its licensors. All rights are reserved. All licensed material will reference the licensor that has granted SKF the right to use the material. The information and software made available on this website / app may not be reproduced, duplicated, copied, transferred, distributed, stored, modified, downloaded or otherwise exploited for any commercial use without the prior written approval of SKF. However, it may be reproduced, stored and downloaded for use by individuals without prior written approval of SKF. Under no circumstances may this information or software be supplied to third parties.

This website /app includes certain images used under license from Shutterstock, Inc.

Trademarks and Patents

All trademarks, brand names, and corporate logos displayed on the website / app are the property of SKF or its licensors, and may not be used in any way without prior written approval by SKF. All licensed trademarks published on this website / app reference the licensor that has granted SKF the right to use the trademark. Access to this website / app does not grant to the user any license under any patents owned by or licensed to SKF.

Changes

SKF reserves the right to make changes or additions to this website / app at any time.