

FY 25 TF

Square flanged ball bearing unit with set screw locking, cast iron housing, ISO

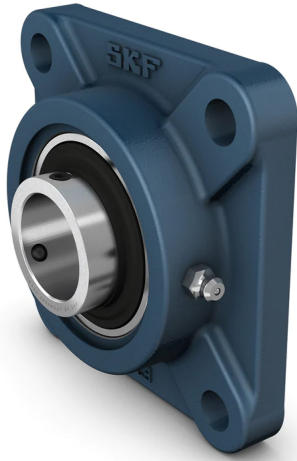

These square flanged ball bearing units are compliant with ISO standards. They consist of an insert bearing, with an extended inner ring and set screw locking, and are suitable for applications where the direction of rotation is constant or alternating. The bearing is mounted in a cast iron housing, which can be bolted to a machine wall or frame. Ball bearing units can accommodate moderate initial misalignment, but normally do not permit axial displacement.

- Resist high levels of contamination
- Designed for high temperatures and speeds
- Accommodate relatively heavy loads
- Cost-effective

Overview

Dimensions

Bearing width, total	1.343 in
Centre distance between bolt holes	2.756 in
Housing overall width	1.181 in
Shaft diameter	0.984 in

Performance

Basic dynamic load rating	3 147 lbf
Basic static load rating	1 754 lbf
Limiting speed	7 000 r/min
Note	Limiting speed with shaft tolerance h6

Properties

Bore type	Cylindrical
Coating	Without
Fastening bolt hole type	Plain
Flanged housing type	Square
Grease fitting	With
Housing type	Flanged
Lubricant	Grease
Material, bearing	Bearing steel
Material, housing	Cast iron
Number of bolt holes for fasteners	4
Relubrication hole	With
Retaining feature, inner ring	Set screws

Rubber seating ring	Without
Sealing type	Contact, standard
Sealing, bearing	Seal and flinger on both sides
Sealing, unit	Optional end cover

Technical Specification

Compliance with standard	ISO
Purpose specific	For material handling applications
Material, housing	Cast iron
Sealing, bearing	Seal and flinger on both sides
Sealing type, bearing	Contact, standard
Sealing, unit	Optional end cover
Coating	Without

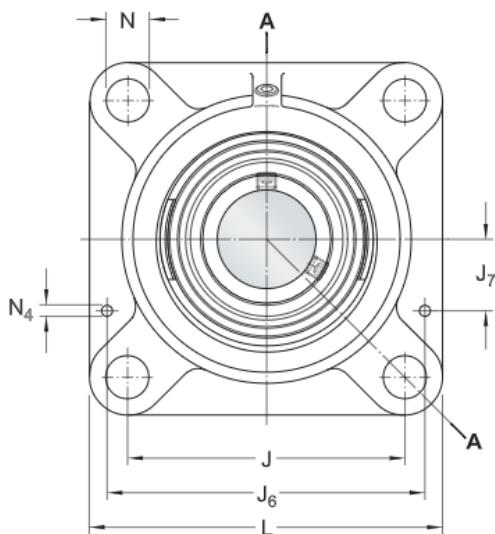
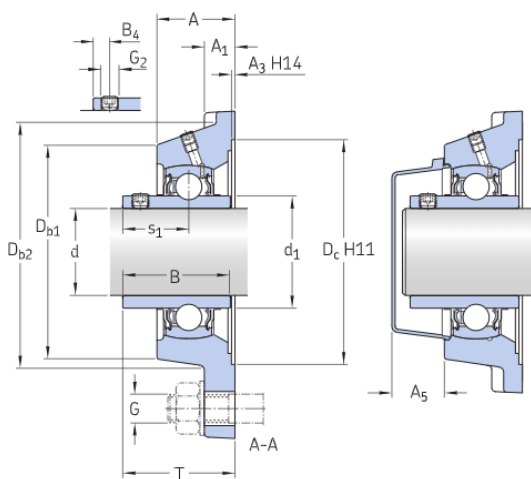

Dimensions

d	0.984 in	Bore diameter
d ₁	≈ 1.328 in	Outer diameter of inner ring
A	1.181 in	Overall width
A ₁	0.472 in	Flange width
A ₃	0.126 in	Depth of centring recess
A ₅	0.807 in	Standout of end cover
B	1.343 in	Width of inner ring
B ₄	0.197 in	Distance from locking device side face to thread centre
D _{b1}	2.559 in	Top external diameter
D _{b2}	2.795 in	Base external diameter
D _c	2.937 in	Diameter of housing centering recess
J	2.756 in	Distance between attachment bolts
L	3.74 in	Overall length

N	0.453 in	Diameter of attachment bolt hole
s_1	0.78 in	Distance from locking device side face to raceway centre
T	1.528 in	Overall unit width
Dowel pins		
J_6	3.268 in	Distance of dowel pins
J_7	0.748 in	Axial offset of dowel pins
N_4	0.157 in	Recommended diameter for dowel pins

Calculation data

Basic dynamic load rating	C	3 147 lbf
Basic static load rating	C_0	1 754 lbf
Fatigue load limit	P_u	75 lbf
Limiting speed		7 000 r/min
		Limiting speed with shaft tolerance h6

Mass

Mass bearing unit	1.521 lb
-------------------	----------

Mounting information

Set screw	G_2	M6x0.75
Hexagonal key size for set screw		0.118 in
Recommended tightening torque for set screw		35.403 lbf-in
Recommended diameter for attachment bolts, mm	G	10.008 mm
Recommended diameter for attachment bolts, inch	G	0.375 in

Included products

Housing

FY 505 M

Bearing

YAR 205-2F

Associated products

End cover

ECY 205

Terms and conditions

By accessing and using this website / app owned and published by AB SKF (publ.) (556007-3495 · Gothenburg) ("SKF"), you agree to the following terms and conditions:

Warranty Disclaimer and Limitation of Liability

Although every care has been taken to assure the accuracy of the information on this website / app, SKF provides this information "AS IS" and DISCLAIMS ALL WARRANTIES, EXPRESS OR IMPLIED, INCLUDING, BUT NOT LIMITED TO, IMPLIED WARRANTIES OF MERCHANTABILITY AND FITNESS FOR A PARTICULAR PURPOSE. You acknowledge that your use of this website / app is at your sole risk, that you assume full responsibility for all costs associated with use of this website / app, and that SKF shall not be liable for any direct, incidental, consequential, or indirect damages of any kind arising out of your access to, or use of the information or software made available on this website / app. Any warranties and representations in this website / app for SKF products or services that you purchase or use will be subject to the agreed upon terms and conditions in the contract for such product or service. Further, for non-SKF websites / apps that are referenced in our website / app or where a hyperlink appears, SKF makes no warranties concerning the accuracy or reliability of the information in these websites / apps and assumes no responsibility for material created or published by third parties contained therein. In addition, SKF does not warrant that this website / app or these other linked websites / apps are free from viruses or other harmful elements.

Copyright

Copyright in this website / app copyright of the information and software made available on this website / app rest with SKF or its licensors. All rights are reserved. All licensed material will reference the licensor that has granted SKF the right to use the material. The information and software made available on this website / app may not be reproduced, duplicated, copied, transferred, distributed, stored, modified, downloaded or otherwise exploited for any commercial use without the prior written approval of SKF. However, it may be reproduced, stored and downloaded for use by individuals without prior written approval of SKF. Under no circumstances may this information or software be supplied to third parties.

This website /app includes certain images used under license from Shutterstock, Inc.

Trademarks and Patents

All trademarks, brand names, and corporate logos displayed on the website / app are the property of SKF or its licensors, and may not be used in any way without prior written approval by SKF. All licensed trademarks published on this website / app reference the licensor that has granted SKF the right to use the trademark. Access to this website / app does not grant to the user any license under any patents owned by or licensed to SKF.

Changes

SKF reserves the right to make changes or additions to this website / app at any time.