

# Tie-rod Type Hydraulic Cylinder

## **CHA Series**

**CHQ**

**CHK**□

**CHN**

**CHM**

**CHS**□

**CH2**□

**CHA**

Related  
Products

**D-**□

### **CHA Series**

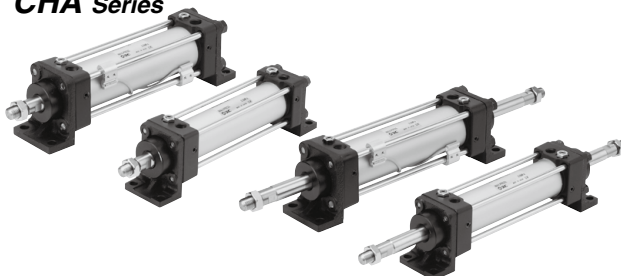

Nominal pressure: **3.5 MPa**

Bore size (mm): 40, 50, 63, 80, 100, 125, 160

# Tie-rod Type Hydraulic Cylinder Double Acting/Single Rod

## CHA Series

3.5 MPa

∅40, ∅50, ∅63, ∅80, ∅100, ∅125, ∅160

### How to Order

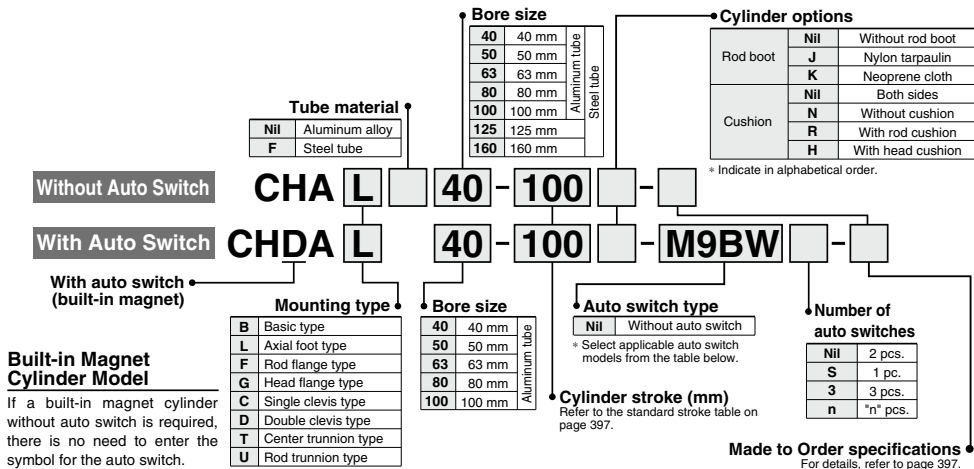

### Built-in Magnet Cylinder Model

If a built-in magnet cylinder without auto switch is required, there is no need to enter the symbol for the auto switch. (Example) CHDAB50-100

### Applicable Auto Switches

Refer to pages 431 to 490 for further details on each auto switch.

Type	Special function	Electrical entry	Indicator light	Wiring (output)	Load voltage		Auto switch model		Lead wire length (m)					Pre-wired connector	Applicable load
					DC	AC	Tie-rod mount	Band mount	0.5 (Nil)	1 (M)	3 (L)	5 (Z)	None		
Solid state auto switch		Grommet	No	3-wire (NPN)	5 V, 12 V	—	M9N	—	●	●	●	○	—	○	IC circuit
				3-wire (PNP)			M9P	—	●	●	●	○	—	○	
		2-wire		M9B			—	●	●	●	○	—	○		
		2-wire		M9A			—	●	●	●	○	—	○		
	Terminal conduit	Yes	3-wire (NPN)	5 V, 12 V	—	G39	—	—	—	—	●	—	—	○	IC circuit
			2-wire	12 V	—	K39	—	—	—	—	—	●	—	—	○
	Grommet	Diagnostic indication (2-color indicator)	Yes	3-wire (NPN)	5 V, 12 V	—	M9NW	—	●	●	●	○	—	○	IC circuit
				3-wire (PNP)	M9PW		—	●	●	●	○	—	○		
		Water resistant (2-color indicator)	Yes	2-wire	24 V	—	M9BW	—	●	●	●	○	—	○	—
				2-wire	12 V		M9AW	—	●	●	●	○	—	○	
Diagnostic output (2-color indicator)		Yes	3-wire (NPN)	5 V, 12 V	—	M9NA <sup>*1</sup>	—	○	○	○	○	○	—	○	IC circuit
			3-wire (PNP)	M9PA <sup>*1</sup>		—	○	○	○	○	○	○	—	○	
Reed auto switch		Grommet	No	2-wire	24 V	12 V	F59F	—	●	—	—	—	—	○	IC circuit
				2-wire (NPN equiv.)			A96	—	●	—	—	—	—	○	
		—		A93			—	●	●	●	○	—	○		
		—		A90			—	●	●	●	○	—	○		
	Terminal conduit	Yes	No	2-wire	24 V	12 V	—	A54	—	●	—	—	—	○	IC circuit
							—	A64	—	●	—	—	—	○	
	DIN terminal	Yes	No	2-wire	24 V	12 V	—	A33	—	—	—	—	●	—	—
							—	A34	—	—	—	—	●	—	
	Grommet	Yes	No	2-wire	24 V	12 V	—	A44	—	—	—	—	●	—	—
							—	A59W	—	●	—	—	—	○	

\*1 Water resistant type auto switches can be mounted on the above models, but in such case SMC cannot guarantee water resistance. Consult with SMC regarding water resistant types with the above model numbers.

\* Lead wire length symbols: 0.5 m ..... Nil (Example) M9NW  
1 m ..... M (Example) M9NWM  
3 m ..... L (Example) M9NWL  
5 m ..... Z (Example) M9NWZ

\* Solid state auto switches marked "○" are produced upon receipt of order.

\*\* Types D-G□, K59, G5□W, K59W, G5BA, G5F, G5NT, B5□, B64, and B59W cannot be mounted on ø63 bore size cylinders.

\* Since there are applicable auto switches other than listed, refer to page 413 for details.

\* For details about auto switches with pre-wired connector, refer to pages 474 and 475.

\* D-A9□, M9□, M9□W, M9□A auto switches are shipped together (not assembled). (Only auto switch mounting brackets are packed assembled.)

# Tie-rod Type Hydraulic Cylinder Double Acting/Single Rod **CHA Series**



## Made to Order specifications

For details, refer to page 415.

Symbol	Specifications
-XC22	Fluororubber seals

## Accessories (Options)

Bracket pin, Knuckle bracket, Knuckle pin, Knuckle, Y-type knuckle, Rod end nut

\* Refer to pages 408 and 409 for part numbers and dimensions.

## Models

Model	Tube material	Bore size (mm)
CHA	Aluminum alloy	40, 50, 63, 80, 100
CHAF	Steel	40, 50, 63, 80, 100, 125, 160

## Specifications

Action	Double acting/Single rod
Fluid	Hydraulic fluid
Nominal pressure	3.5 MPa
Proof pressure	5.0 MPa
Maximum allowable pressure	3.5 MPa
Minimum operating pressure	0.25 MPa
Ambient and fluid temperature	Without auto switch: -10° to 80°C With auto switch: -10° to 60°C
Piston speed	8 to 300 mm/s
Cushion	Cushion seal
Stroke length tolerance	to 100st $^{+0.8}_0$ , 100 to 250st $^{+1.0}_0$ , 250 to 630st $^{+1.25}_0$ 630 to 1000st $^{+1.4}_0$ , 1000 to 1500st $^{+1.8}_0$
Mounting	Basic type (B), Axial foot type (L), Rod flange type (F) Head flange type (G), Single clevis type (C), Double clevis type (D), Center trunnion type (T), Rod trunnion type (U)

Note) Refer to page 214 for definitions of terms related to pressure.

## Standard Strokes

Bore size (mm)	Standard strokes (mm)
40	25 to 1000
50	25 to 1000
63	25 to 1000
80	25 to 1300
100	25 to 1500
125	50 to 1300
160	50 to 1500

Note) Refer to pages 232 and 233 to determine stroke limitation depending on the type of mounting brackets that will be used. Then make your selection.

## Cushion Strokes (For Rod Side and Head Side)

Bore size (mm)	Effective cushion stroke (mm)
40	15
50	15
63	17
80	20
100	20
125	20
160	22

## Hydraulic Fluid Compatibility

Hydraulic fluid	Compatibility
Standard mineral hydraulic fluid	Compatible
W/O hydraulic fluid	Compatible
O/W hydraulic fluid	Compatible
Water/Glycol hydraulic fluid	Not compatible
Phosphate hydraulic fluid	Not compatible

## Rod Boot Material

Symbol	Material	Maximum ambient temperature
J	Nylon tarpaulin	70
K	Heat resistant tarpaulin	110 *

\* Maximum ambient temperature for the rod boot itself.

CHK

CHN

CHM

CHS

CH2

CHA

Related Products

D-

## Theoretical Output

Unit: N

Bore size (mm)	Rod size (mm)	Operating direction	Piston area (mm <sup>2</sup> )	Operating pressure (MPa)					
				1	1.5	2	2.5	3	3.5
40	18	OUT	1257	1257	1886	2514	3143	3771	4400
		IN	1002	1002	1503	2004	2505	3006	3507
50	20	OUT	1963	1963	2945	3926	4908	5889	6871
		IN	1649	1649	2474	3298	4123	4947	5772
63	22.4	OUT	3117	3117	4676	6234	7793	9351	10910
		IN	2723	2723	4085	5446	6808	8169	9531
80	28	OUT	5027	5027	7541	10054	12568	15081	17595
		IN	4411	4411	6617	8822	11028	13233	15439
100	35.5	OUT	7854	7854	11781	15708	19635	23562	27489
		IN	6864	6864	10296	13728	17160	20592	24024
125	35.5	OUT	12272	12272	18408	24544	30680	36816	42952
		IN	11282	11282	16923	22564	28205	33846	39487
160	45	OUT	20106	20106	30159	40212	50265	60318	70371
		IN	18516	18516	27774	37032	46290	55548	64806

## Weight

### CH□A Series (Built-in magnet)

Unit: kg

Bore size (mm)		40	50	63	80	100	
(0 mm stroke)	Basic weight	Basic type (B)	1.3	2.0	2.6	4.3	6.5
		Axial foot type (L)	1.8	2.9	3.8	6.4	10.0
		Flange type (F, G)	1.6	2.4	3.2	5.2	8.2
		Single clevis type (C)	1.7	2.6	3.6	5.8	9.0
		Double clevis type (D)	1.8	2.9	3.8	6.5	9.9
		Rod trunnion type (U)	1.6	2.4	3.1	6.0	9.4
		Center trunnion type (T)	1.7	2.8	3.4	5.8	9.2
		Additional weight per 10 mm stroke	0.05	0.07	0.09	0.12	0.16

Calculation (Example) CHAL50-100

- Basic weight ..... 2.9 (foot type, ø50)
  - Additional weight ..... 0.07/10 mm stroke
  - Cylinder stroke ..... 100 mm
- $$2.9 + 0.07 \times 100 / 10 = 3.6 \text{ kg}$$

### CH□F Series (Steel tube)

Unit: kg

Bore size (mm)		40	50	63	80	100	125	160	
(0 mm stroke)	Basic weight	Basic type (B)	1.5	2.1	2.7	4.7	7.1	9.2	15.8
		Axial foot type (L)	2.0	3.1	3.9	6.8	10.6	15.8	26.5
		Flange type (F, G)	1.7	2.6	3.2	5.7	8.8	12.1	26.7
		Single clevis type (C)	1.9	2.8	3.6	6.3	9.6	13.0	22.9
		Double clevis type (D)	2.0	3.1	3.9	7.0	10.5	14.7	25.6
		Rod trunnion type (U)	1.7	2.6	3.2	6.5	10.0	13.7	23.6
		Center trunnion type (T)	1.9	2.9	3.4	6.2	9.8	12.9	22.7
		Additional weight per 10 mm stroke	0.09	0.08	0.10	0.19	0.24	0.31	0.47

**Construction**

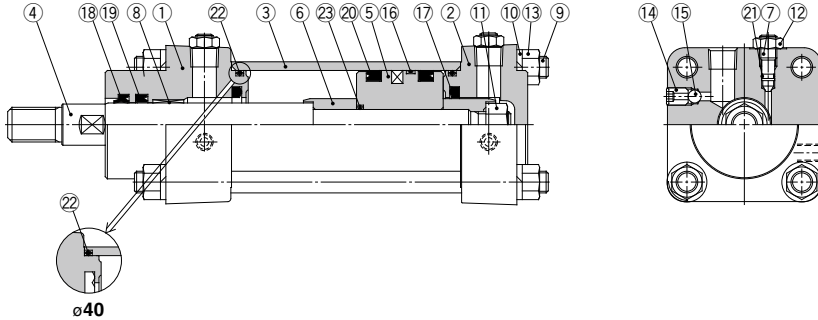

**CHQ**

**CHK**

**CHN**

**CHM**

**CHS**

**CH2**

**CHA**

Related Products

**D-**

**Parts List**

No.	Description	Material	Note
1	Rod cover	Aluminum alloy	70% flat black
2	Head cover	Aluminum alloy	70% flat black
3	Cylinder tube	Aluminum alloy	Hard anodized
		Carbon steel	
4	Piston rod	Carbon steel	Hard chromium electroplated
5	Piston	Aluminum alloy	
6	Cushion ring	Rolled steel	
7	Needle valve	Rolled steel	
8	Bushing	Lead bronze	
9	Tie-rod	Carbon steel	
10	Tie-rod washer	Steel wire	
11	Piston nut	Rolled steel	
12	Needle valve nut	Carbon steel	
13	Tie-rod nut	Carbon steel	
14	Air release valve	Alloy steel	
15	Check ball	Bearing steel	
16	Wear ring	Resin	
17	Cushion seal	—	
18	Wiper ring	NBR	
19	Rod seal	NBR	
20	Piston seal	NBR	
21	Needle valve seal	NBR	
22	Cylinder tube gasket	NBR	
23	Piston gasket	NBR	

**Replacement Parts: Seal Kit**

Bore size (mm)	Seal kit no.	Content
40	CHA40-PS	Nos. 17 to 22 from the chart at left
50	CHA50-PS	
63	CHA63-PS	
80	CHA80-PS	
100	CHA100-PS	
125	CHA125-PS	
160	CHA160-PS	

\* Seal kit consists of items 17 through 22 and can be ordered using the seal kit number for each bore size.

# CHA Series

## Dimensions

### Basic type: CHAB

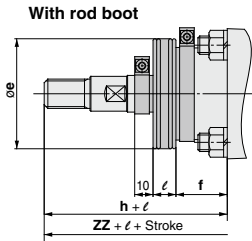
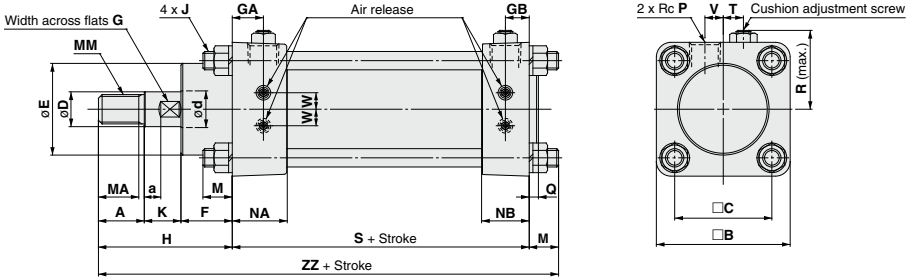

Bore size (mm)	A	a	$\square B$	$\square C$	D	d	E	F	G	GA	GB	J	K	M	MA	MM	NA	NB	P	Q	R	S	T	V	W
40	23	10	60	44	$17_{-0.018}^0$	18	$45_{-0.062}^0$	25	14	17.5	9.5	M8 x 1.25	18	13	20	M14 x 1.5	30	22	1/4	5	37	106	11	7.5	8
50	25	9	73	53	$19_{-0.021}^0$	20	$50_{-0.082}^0$	28	17	17	13	M10 x 1.5	20	16	22	M16 x 1.5	30	26	3/8	5	43	112	11	10	9
63	28	8	80	60	$21_{-0.021}^0$	22.4	$55_{-0.074}^0$	30	17	17	13	M10 x 1.5	22	16	25	M18 x 1.5	30	26	3/8	5	47	116	11	12	10
80	32	8	100	75	$26_{-0.021}^0$	28	$65_{-0.074}^0$	32	22	20	15	M12 x 1.75	26	19	29	M22 x 1.5	35	30	1/2	5	57	127	11	16	13
100	38	6.5	118	90	$34_{-0.025}^0$	35.5	$80_{-0.074}^0$	35	27	19	16	M12 x 1.75	27	21	34	M27 x 2	35	32	1/2	8	66	137	12	20	16
125	38	6.5	140	112	$34_{-0.025}^0$	35.5	$80_{-0.074}^0$	35	27	19	16	M14 x 2	27	24	34	M27 x 2	35	32	1/2	8	77	137	12	20	16
160	42	9	174	140	$43_{-0.025}^0$	45	$100_{-0.087}^0$	38	36	22	18	M16 x 2	28	27	38	M33 x 2	40	36	3/4	8	94	155	12	24	20

(mm)

Bore size (mm)	Without rod boot		With rod boot					
	H	ZZ	e	f	h	$\ell$	ZZ	
40	66	185	55	25	92		211	
50	73	201	60	28	99	1/4 stroke	227	
63	80	212	65	30	106		238	
80	90	236	80	32	116		262	
100	100	258	100	35	123		281	
125	100	261	100	35	123	1/5 stroke	284	
160	108	290	120	38	131		313	

Foot type: CHAL

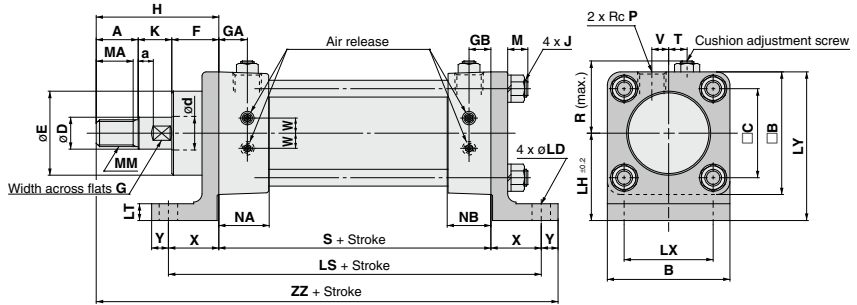

With rod boot

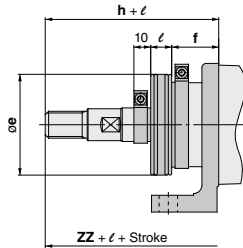

(mm)

Bore size (mm)	A	a	B	□B	□C	D	d	E	F	G	GA	GB	J	K	LD	LH	LS	LT	LX	LY	M	MA	MM	NA	NB
40	23	10	60	60	44	17 <sup>0</sup> <sub>-0.018</sub>	18	45 <sup>0</sup> <sub>-0.062</sub>	25	14	17.5	9.5	M8 x 1.25	18	9	47	160	8	44	77	10	20	M14 x 1.5	30	22
50	25	9	73	73	53	19 <sup>0</sup> <sub>-0.021</sub>	20	50 <sup>0</sup> <sub>-0.062</sub>	28	17	17	13	M10 x 1.5	20	11	52	172	10	53	88.5	12	22	M16 x 1.5	30	26
63	28	8	80	80	60	21 <sup>0</sup> <sub>-0.021</sub>	22.4	55 <sup>0</sup> <sub>-0.074</sub>	30	17	17	13	M10 x 1.5	22	11	55	190	10	60	95	12	25	M18 x 1.5	30	26
80	32	8	100	100	75	26 <sup>0</sup> <sub>-0.021</sub>	28	65 <sup>0</sup> <sub>-0.074</sub>	32	22	20	15	M12 x 1.75	26	13	65	207	12	75	115	14	29	M22 x 1.5	35	30
100	38	6.5	118	118	90	34 <sup>0</sup> <sub>-0.025</sub>	35.5	80 <sup>0</sup> <sub>-0.074</sub>	35	27	19	16	M12 x 1.75	27	13	80	231	14	90	139	14	34	M27 x 2	35	32
125	38	6.5	140	140	112	34 <sup>0</sup> <sub>-0.025</sub>	35.5	80 <sup>0</sup> <sub>-0.074</sub>	35	27	19	16	M14 x 2	27	15	100	247	16	112	170	16	34	M27 x 2	35	32
160	42	9	174	174	140	43 <sup>0</sup> <sub>-0.025</sub>	45	100 <sup>0</sup> <sub>-0.087</sub>	38	36	22	18	M16 x 2	28	17	110	275	18	140	197	18	38	M33 x 2	40	36

(mm)

Bore size (mm)	P	R	S	T	V	W	X	Y	Without rod boot				With rod boot			
									H	ZZ	e	f	h	l	ZZ	
40	1/4	37	106	11	7.5	8	27	8	66	207	55	25	92	233		
50	3/8	43	112	11	10	9	30	10	73	225	60	28	99	1/4 stroke 251		
63	3/8	47	116	11	12	10	37	10	80	243	65	30	106	269		
80	1/2	57	127	11	16	13	40	13	90	270	80	32	116	296		
100	1/2	66	137	12	20	16	47	13	100	297	100	35	123	1/5 stroke 322		
125	1/2	77	137	12	20	16	55	15	100	307	100	35	123	328		
160	3/4	94	155	12	24	20	60	20	108	343	120	38	131	366		

- CHQ**
- CHK
- CHN
- CHM
- CHS
- CH2
- CHA**
- Related Products
- D-

# CHA Series

## Dimensions

### Rod flange type: CHAF

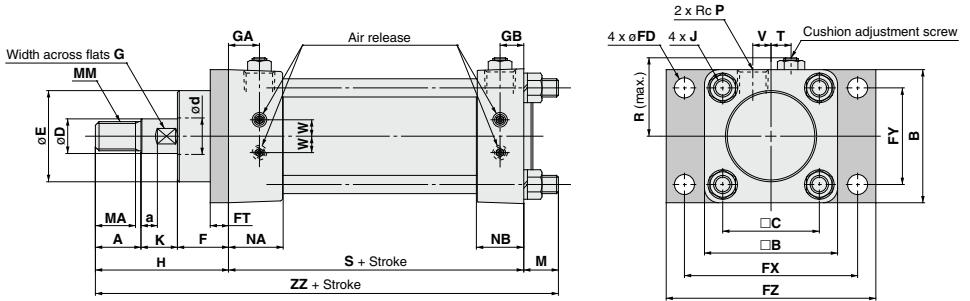

### With rod boot

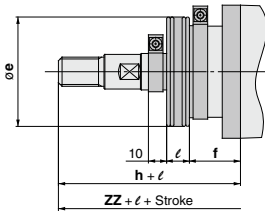

Bore size (mm)	A	a	B	□B	□C	D	d	E	F	FD	FT	FX	FY	FZ	G	GA	GB	J	K	M	MA	MM	NA	NB	P
40	23	10	60	60	44	17 <sub>-0.018</sub>	18	45 <sub>-0.062</sub>	25	9	10	77	44	95	14	17.5	9.5	M8 x 1.25	18	16	20	M14 x 1.5	30	22	1/4
50	25	9	73	73	53	19 <sub>-0.021</sub>	20	50 <sub>-0.082</sub>	28	11	10	95	53	115	17	17	13	M10 x 1.5	20	22	22	M16 x 1.5	30	26	3/8
63	28	8	80	80	60	21 <sub>-0.021</sub>	22.4	55 <sub>-0.074</sub>	30	11	12	102	60	122	17	17	13	M10 x 1.5	22	20	25	M18 x 1.5	30	26	3/8
80	32	8	100	100	75	26 <sub>-0.021</sub>	28	65 <sub>-0.074</sub>	32	13	12	130	75	155	22	20	15	M12 x 1.75	26	26	29	M22 x 1.5	35	30	1/2
100	38	6.5	118	118	90	34 <sub>-0.025</sub>	35.5	80 <sub>-0.074</sub>	35	13	16	145	90	172	27	19	16	M12 x 1.75	27	26	34	M27 x 2	35	32	1/2
125	38	6.5	140	140	112	34 <sub>-0.025</sub>	35.5	80 <sub>-0.074</sub>	35	15	18	170	112	200	27	19	16	M14 x 2	27	30	34	M27 x 2	35	32	1/2
160	42	9	174	174	140	43 <sub>-0.025</sub>	45	100 <sub>-0.087</sub>	38	17	20	205	140	240	36	22	18	M16 x 2	28	34	38	M33 x 2	40	36	3/4

(mm)

Bore size (mm)	R	S	T	V	W	Without rod boot		With rod boot				
						H	ZZ	e	f	h	$\ell$	ZZ
40	37	106	11	7.5	8	66	188	55	25	92		214
50	43	112	11	10	9	73	207	60	28	99	1/4 stroke	233
63	47	116	11	12	10	80	216	65	30	106		242
80	57	127	11	16	13	90	243	80	32	116		269
100	66	137	12	20	16	100	263	100	35	123	1/5 stroke	286
125	77	137	12	20	16	100	267	100	35	123		290
160	94	155	12	24	20	108	297	120	38	131		320



Head flange type: CHAG

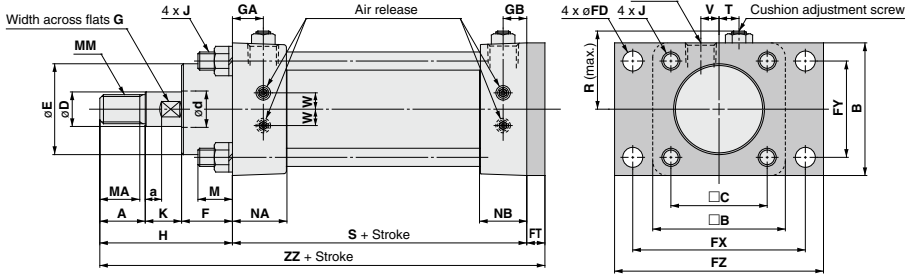

With rod boot

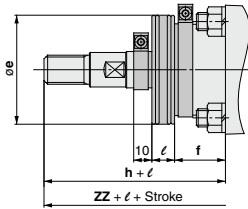

(mm)

Bore size (mm)	A	a	□B	□C	D	d	E	F	FD	FT	FX	FY	FZ	G	GA	GB	J	K	M	MA	MM	NA	NB	P	R
40	23	10	60	44	17 <sub>-0.018</sub> <sup>0</sup>	18	45 <sub>-0.062</sub> <sup>0</sup>	25	9	10	77	44	95	14	17.5	9.5	M8 x 1.25	18	16	20	M14 x 1.5	30	22	1/4	37
50	25	9	73	53	19 <sub>-0.021</sub> <sup>0</sup>	20	50 <sub>-0.082</sub> <sup>0</sup>	28	11	10	95	53	115	17	17	13	M10 x 1.5	20	22	22	M16 x 1.5	30	26	3/8	43
63	28	8	80	60	21 <sub>-0.021</sub> <sup>0</sup>	22.4	55 <sub>-0.074</sub> <sup>0</sup>	30	11	12	102	60	122	17	17	13	M10 x 1.5	22	20	25	M18 x 1.5	30	26	3/8	47
80	32	8	100	75	26 <sub>-0.021</sub> <sup>0</sup>	28	65 <sub>-0.074</sub> <sup>0</sup>	32	13	12	130	75	155	22	20	15	M12 x 1.75	26	26	29	M22 x 1.5	35	30	1/2	57
100	38	6.5	118	90	34 <sub>-0.025</sub> <sup>0</sup>	35.5	80 <sub>-0.074</sub> <sup>0</sup>	35	13	16	145	90	172	27	19	16	M12 x 1.75	27	26	34	M27 x 2	35	32	1/2	66
125	38	6.5	140	112	34 <sub>-0.025</sub> <sup>0</sup>	35.5	80 <sub>-0.074</sub> <sup>0</sup>	35	15	18	170	112	200	27	19	16	M14 x 2	27	30	34	M27 x 2	35	32	1/2	77
160	42	9	174	140	43 <sub>-0.025</sub> <sup>0</sup>	45	100 <sub>-0.087</sub> <sup>0</sup>	38	17	20	205	140	240	36	22	18	M16 x 2	28	34	38	M33 x 2	40	36	3/4	94

(mm)

Bore size (mm)	S	T	V	W	Without rod boot					With rod boot					
					H	ZZ	e	f	h	ℓ	ZZ				
40	106	11	7.5	8	66	182	55	25	92						208
50	112	11	10	9	73	195	60	28	99					1/4 stroke	221
63	116	11	12	10	80	208	65	30	106					1/4 stroke	234
80	127	11	16	13	90	229	80	32	116					1/4 stroke	255
100	137	12	20	16	100	253	100	35	123					1/5 stroke	276
125	137	12	20	16	100	255	100	35	123					1/5 stroke	278
160	155	12	24	20	108	283	120	38	131					1/5 stroke	306

- CHQ**
- CHK
- CHN
- CHM
- CHS
- CH2
- CHA**
- Related Products
- D-

# CHA Series

## Dimensions

### Single clevis type: CHAC

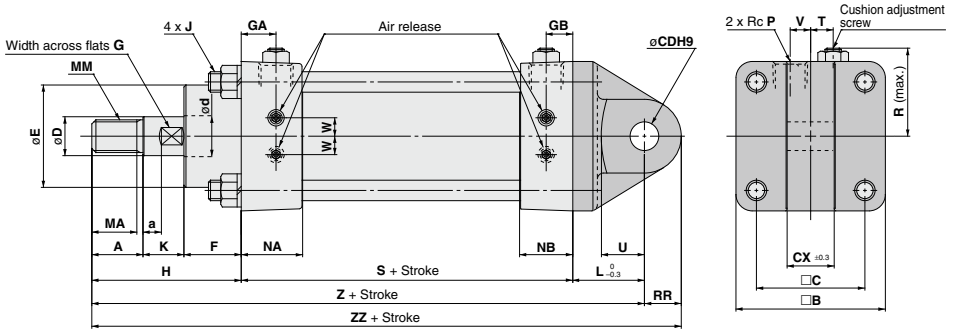

#### With rod boot

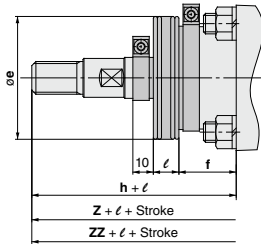

Bore size (mm)	A	a	□B	□C	CDH9	CX	D	d	E	F	G	GA	GB	J	K	L	MA	MM	NA	NB	P	R	RR	S
40	23	10	60	44	12 <sup>+0.043</sup> <sub>0</sub>	21	17 <sup>0</sup> <sub>-0.018</sub>	18	45 <sup>0</sup> <sub>-0.062</sub>	25	14	17.5	9.5	M8 x 1.25	18	32	20	M14 x 1.5	30	22	1/4	37	15	106
50	25	9	73	53	14 <sup>+0.043</sup> <sub>0</sub>	23	19 <sup>0</sup> <sub>-0.021</sub>	20	50 <sup>0</sup> <sub>-0.062</sub>	28	17	17	13	M10 x 1.5	20	35	22	M16 x 1.5	30	26	3/8	43	18	112
63	28	8	80	60	16 <sup>+0.043</sup> <sub>0</sub>	27	21 <sup>0</sup> <sub>-0.021</sub>	22.4	55 <sup>0</sup> <sub>-0.074</sub>	30	17	17	13	M10 x 1.5	22	40	25	M18 x 1.5	30	26	3/8	47	20	116
80	32	8	100	75	18 <sup>+0.043</sup> <sub>0</sub>	31	26 <sup>0</sup> <sub>-0.021</sub>	28	65 <sup>0</sup> <sub>-0.074</sub>	32	22	20	15	M12 x 1.75	26	45	29	M22 x 1.5	35	30	1/2	57	22	127
100	38	6.5	118	90	20 <sup>+0.052</sup> <sub>0</sub>	35	34 <sup>0</sup> <sub>-0.025</sub>	35.5	80 <sup>0</sup> <sub>-0.074</sub>	35	27	19	16	M12 x 1.75	27	50	34	M27 x 2	35	32	1/2	66	24	137
125	38	6.5	140	112	22 <sup>+0.052</sup> <sub>0</sub>	41	34 <sup>0</sup> <sub>-0.025</sub>	35.5	80 <sup>0</sup> <sub>-0.074</sub>	35	27	19	16	M14 x 2	27	55	34	M27 x 2	35	32	1/2	77	26	137
160	42	9	174	140	25 <sup>+0.052</sup> <sub>0</sub>	54	43 <sup>0</sup> <sub>-0.025</sub>	45	100 <sup>0</sup> <sub>-0.087</sub>	38	36	22	18	M16 x 2	28	65	38	M33 x 2	40	36	3/4	94	30	155

(mm)

Bore size (mm)	T	U	V	W	Without rod boot		With rod boot																	
					H	Z	ZZ	e	f	h	ℓ	Z	ZZ											
40	11	18	7.5	8	66	204	219	55	25	92													230	245
50	11	21	10	9	73	220	238	60	28	99													246	264
63	11	23	12	10	80	236	258	65	30	106													262	284
80	11	26	16	13	90	262	284	80	32	116													288	310
100	12	30	20	16	100	287	311	100	35	123													310	334
125	12	30	20	16	100	292	318	100	35	123													315	341
160	12	40	24	20	108	328	358	120	38	131													351	381

**Double clevis type: CHAD**

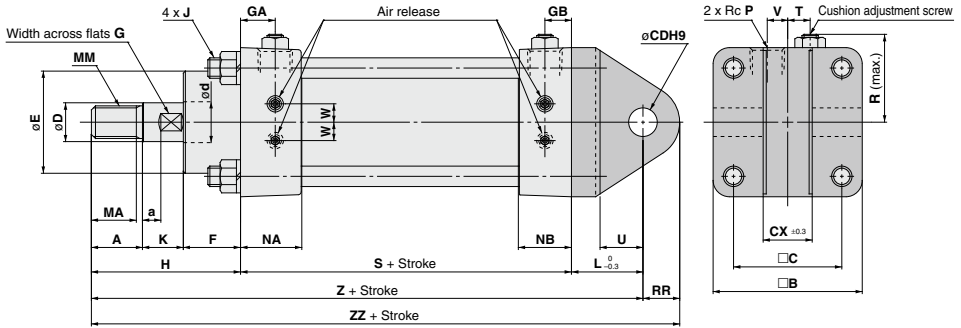

**With rod boot**

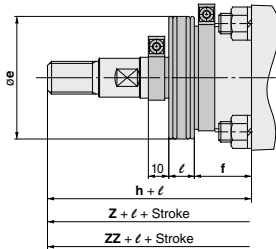

(mm)

Bore size (mm)	A	a	□B	□C	CDH9	CX	D	d	E	F	G	GA	GB	J	K	L	MA	MM	NA	NB	P	R	RR	S
40	23	10	60	44	ø12H9 <sup>+0.043</sup> / <sub>0</sub>	22	17 <sup>0</sup> / <sub>-0.018</sub>	18	45 <sup>0</sup> / <sub>-0.062</sub>	25	14	17.5	9.5	M8 x 1.25	18	32	20	M14 x 1.5	30	22	1/4	37	15	106
50	25	9	73	53	ø14H9 <sup>+0.043</sup> / <sub>0</sub>	24	19 <sup>0</sup> / <sub>-0.021</sub>	20	50 <sup>0</sup> / <sub>-0.062</sub>	28	17	17	13	M10 x 1.5	20	35	22	M16 x 1.5	30	26	3/8	43	18	112
63	28	8	80	60	ø16H9 <sup>+0.043</sup> / <sub>0</sub>	28	21 <sup>0</sup> / <sub>-0.021</sub>	22.4	55 <sup>0</sup> / <sub>-0.074</sub>	30	17	17	13	M10 x 1.5	22	40	25	M18 x 1.5	30	26	3/8	47	20	116
80	32	8	100	75	ø18H9 <sup>+0.043</sup> / <sub>0</sub>	32	26 <sup>0</sup> / <sub>-0.021</sub>	28	65 <sup>0</sup> / <sub>-0.074</sub>	32	22	20	15	M12 x 1.75	26	45	29	M22 x 1.5	35	30	1/2	57	22	127
100	38	6.5	118	90	ø20H9 <sup>+0.052</sup> / <sub>0</sub>	36	34 <sup>0</sup> / <sub>-0.025</sub>	35.5	80 <sup>0</sup> / <sub>-0.074</sub>	35	27	19	16	M12 x 1.75	27	50	34	M27 x 2	35	32	1/2	66	24	137
125	38	6.5	140	112	ø22H9 <sup>+0.052</sup> / <sub>0</sub>	42	34 <sup>0</sup> / <sub>-0.025</sub>	35.5	80 <sup>0</sup> / <sub>-0.074</sub>	35	27	19	16	M14 x 2	27	55	34	M27 x 2	35	32	1/2	77	26	137
160	42	9	174	140	ø25H9 <sup>+0.052</sup> / <sub>0</sub>	55	43 <sup>0</sup> / <sub>-0.025</sub>	45	100 <sup>0</sup> / <sub>-0.087</sub>	38	36	22	18	M16 x 2	28	65	38	M33 x 2	40	36	3/4	94	30	155

(mm)

Bore size (mm)	T	U	V	W	Without rod boot					With rod boot						
					H	Z	ZZ	e	f	h	ℓ	Z	ZZ			
40	11	18	7.5	8	66	204	219	55	25	92					230	245
50	11	21	10	9	73	220	238	60	28	99				1/4 stroke	246	264
63	11	23	12	10	80	236	258	65	30	106					262	284
80	11	26	16	13	90	262	284	80	32	116					288	310
100	12	30	20	16	100	287	311	100	35	123					310	334
125	12	30	20	16	100	292	318	100	35	123				1/5 stroke	315	341
160	12	40	24	20	108	328	358	120	38	131					351	381

# CHA Series

## Dimensions

### Center trunnion type: CHAT

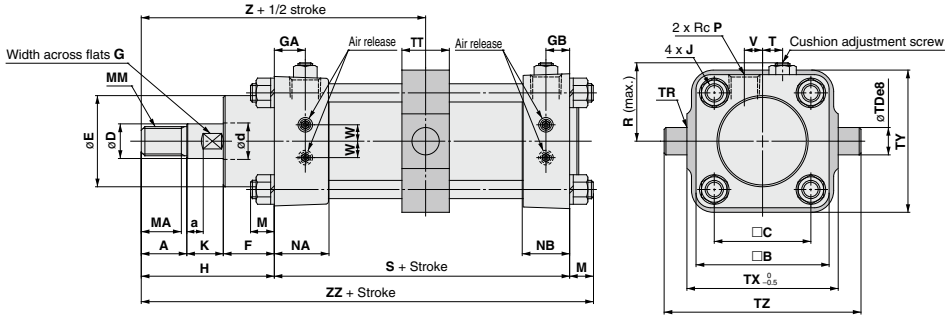

### With rod boot

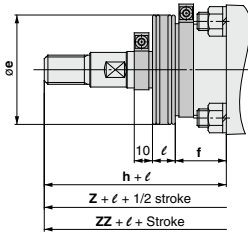

(mm)

Bore size (mm)	A	a	B	C	D	d	E	F	G	GA	GB	J	K	M	MA	MM	NA	NB	P	R	S	T	Tde8	
40	23	10	60	44	17 <sup>0</sup> <sub>-0.018</sub>	18	45 <sup>0</sup> <sub>-0.062</sub>	25	14	17.5	9.5	M8 x 1.25	18	10	20	M14 x 1.5	30	22	1/4	37	106	11	15	15 <sup>-0.032</sup> <sub>-0.059</sub>
50	25	9	73	53	19 <sup>0</sup> <sub>-0.021</sub>	20	50 <sup>0</sup> <sub>-0.062</sub>	28	17	17	13	M10 x 1.5	20	10	22	M16 x 1.5	30	26	3/8	43	112	11	15	15 <sup>-0.032</sup> <sub>-0.059</sub>
63	28	8	80	60	21 <sup>0</sup> <sub>-0.021</sub>	22.4	55 <sup>0</sup> <sub>-0.074</sub>	30	17	17	13	M10 x 1.5	22	10	25	M18 x 1.5	30	26	3/8	47	116	11	15	15 <sup>-0.032</sup> <sub>-0.059</sub>
80	32	8	100	75	26 <sup>0</sup> <sub>-0.021</sub>	28	65 <sup>0</sup> <sub>-0.074</sub>	32	22	20	15	M12 x 1.75	26	13	29	M22 x 1.5	35	30	1/2	57	127	11	25	25 <sup>-0.040</sup> <sub>-0.073</sub>
100	38	6.5	118	90	34 <sup>0</sup> <sub>-0.025</sub>	35.5	80 <sup>0</sup> <sub>-0.074</sub>	35	27	19	16	M12 x 1.75	27	13	34	M27 x 2	35	32	1/2	66	137	12	32	32 <sup>-0.050</sup> <sub>-0.089</sub>
125	38	6.5	140	112	34 <sup>0</sup> <sub>-0.025</sub>	35.5	80 <sup>0</sup> <sub>-0.074</sub>	35	27	19	16	M14 x 2	27	15	34	M27 x 2	35	32	1/2	77	137	12	32	32 <sup>-0.050</sup> <sub>-0.089</sub>
160	42	9	174	140	43 <sup>0</sup> <sub>-0.025</sub>	45	100 <sup>0</sup> <sub>-0.087</sub>	38	36	22	18	M16 x 2	28	17	38	M33 x 2	40	36	3/4	94	155	12	36	36 <sup>-0.050</sup> <sub>-0.089</sub>

(mm)

Bore size (mm)	TR	TT	TX	TY	TZ	V	W	Without rod boot				With rod boot								
								H	Z	ZZ	e	f	h	ℓ	Z	ZZ				
40	R0.5	24	70	65	95	7.5	8	66	123	182	55	25	92					149	208	
50	R0.5	26	83	78	108	10	9	73	131	195	60	28	99	1/4 stroke				157	221	
63	R0.5	26	90	86	115	12	10	80	140	206	65	30	106						166	232
80	R2.5	36	112	106	162	16	13	90	156	230	80	32	116						182	256
100	R2.5	42	140	130	204	20	16	100	170	250	100	35	123	1/5 stroke				193	273	
125	R2.5	42	170	162	234	20	16	100	170	252	100	35	123						193	275
160	R2.5	52	212	200	284	24	20	108	187.5	280	120	38	131						210.5	303

Rod trunnion type: CHAU

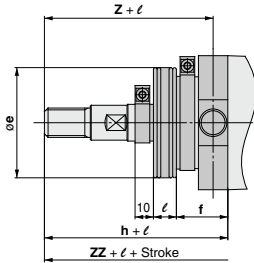
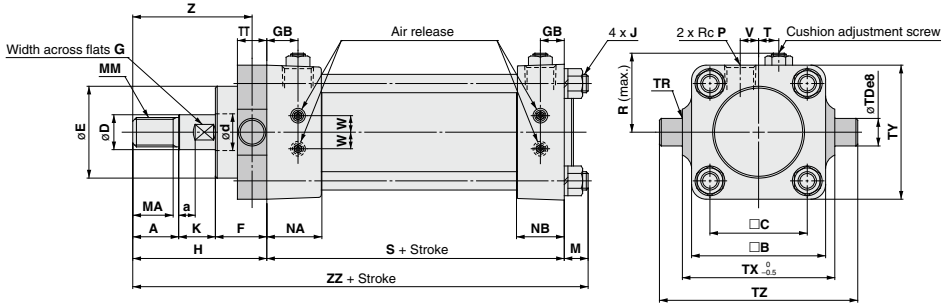

- CHQ
- CHK
- CHN
- CHM
- CHS
- CH2
- CHA
- Related Products
- D-

(mm)

Bore size (mm)	A	a	□B	□C	D	d	E	F	G	GA	GB	J	K	M	MA	MM	NA	NB	P	R	S	T	Tde8
40	23	10	60	44	17 <sup>0</sup> <sub>-0.018</sub>	18	45 <sup>0</sup> <sub>-0.062</sub>	25	14	17.5	9.5	M8 x 1.25	18	10	20	M14 x 1.5	30	22	1/4	37	106	11	15 <sup>-0.032</sup> <sub>-0.059</sub>
50	25	9	73	53	19 <sup>0</sup> <sub>-0.021</sub>	20	50 <sup>0</sup> <sub>-0.062</sub>	28	17	17	13	M10 x 1.5	20	16	22	M16 x 1.5	30	26	3/8	43	112	11	15 <sup>-0.032</sup> <sub>-0.059</sub>
63	28	8	80	60	21 <sup>0</sup> <sub>-0.021</sub>	22.4	55 <sup>0</sup> <sub>-0.074</sub>	30	17	17	13	M10 x 1.5	22	16	25	M18 x 1.5	30	26	3/8	47	116	11	15 <sup>-0.032</sup> <sub>-0.059</sub>
80	32	8	100	75	26 <sup>0</sup> <sub>-0.021</sub>	28	65 <sup>0</sup> <sub>-0.074</sub>	32	22	20	15	M12 x 1.75	26	13	29	M22 x 1.5	35	30	1/2	57	127	11	25 <sup>-0.040</sup> <sub>-0.073</sub>
100	38	6.5	118	90	34 <sup>0</sup> <sub>-0.025</sub>	35.5	80 <sup>0</sup> <sub>-0.074</sub>	35	27	19	16	M12 x 1.75	27	13	34	M27 x 2	35	32	1/2	66	137	12	32 <sup>-0.050</sup> <sub>-0.089</sub>
125	38	6.5	140	112	34 <sup>0</sup> <sub>-0.025</sub>	35.5	80 <sup>0</sup> <sub>-0.074</sub>	35	27	19	16	M14 x 2	27	15	34	M27 x 2	35	32	1/2	77	137	12	32 <sup>-0.050</sup> <sub>-0.089</sub>
160	42	9	174	140	43 <sup>0</sup> <sub>-0.025</sub>	45	100 <sup>0</sup> <sub>-0.087</sub>	38	36	22	18	M16 x 2	28	17	38	M33 x 2	40	36	3/4	94	155	12	36 <sup>-0.050</sup> <sub>-0.089</sub>

(mm)

Bore size (mm)	TR	TT	TX	TY	TZ	V	W	Without rod boot				With rod boot													
								H	Z	ZZ	e	f	h	ℓ	Z	ZZ									
40	R0.5	16	70	60	95	7.5	8	66	58	182	55	25	92										84	208	
50	R0.5	16	83	73	108	10	9	73	65	201	60	28	99											91	227
63	R0.5	16	90	80	115	12	10	80	72	212	65	30	106											98	238
80	R2.5	30	112	100	162	16	13	90	75	230	80	32	116											101	256
100	R2.5	34	140	118	204	20	16	100	83	250	100	35	123											106	273
125	R2.5	34	170	140	234	20	16	100	83	252	100	35	123											106	275
160	R2.5	38	212	174	284	24	20	108	89	280	120	38	131											112	303

## Accessories (Options)

### Bracket pin

Material: Carbon steel

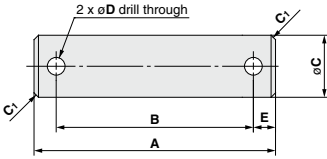

Bore size (mm)	A	B	C (f8)		D	E	Flat washer	Cotter pin	Applicable cylinder type	Order no.
			Size	Tolerance						
40	80	70	12	+0.016 -0.043	3	5	Polished round 12SPCC	ø3 x 18 $\times$ SWRM	ø40 clevis type	AC-C1- bore size
50	94	84	14	+0.016 -0.043	4	5	Polished round 14SPCC	ø4 x 22 $\times$ SWRM	ø50 clevis type	
63	102	92	16	+0.016 -0.043	4	5	Polished round 16SPCC	ø4 x 22 $\times$ SWRM	ø63 clevis type	
80	123	113	18	+0.016 -0.043	5	5	Polished round 18SPCC	ø5 x 28 $\times$ SWRM	ø80 clevis type	
100	147	132	20	+0.020 -0.053	5	7.5	Polished round 20SPCC	ø5 x 30 $\times$ SWRM	ø100 clevis type	
125	169	154	22	+0.020 -0.053	5	7.5	Polished round 22SPCC	ø5 x 35 $\times$ SWRM	ø125 clevis type	
160	205	190	25	+0.020 -0.053	5	7.5	Polished round 24SPCC	ø5 x 35 $\times$ SWRM	ø160 clevis type	

Note) Does not come with other accessories.

### Knuckle bracket

Material: Cast iron

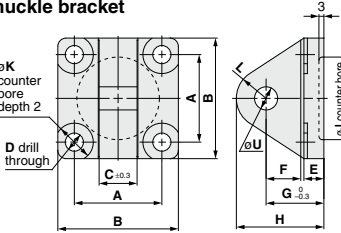

Bore size (mm)	A	B	C	D	E	F	G	H	J	K	L	U(H8)		Hexagon mounting bolt	Applicable cylinder type	Order no.
												Size	Tolerance			
40	44	60	21	9	12	18	32	47	15	19	R15	12	+0.027 0	M6 x 20	ø40 double clevis type	AC-A1- bore size
50	53	73	23	11	12	21	35	53	50	23	R18	14	+0.027 0	M10 x 25	ø50 double clevis type	
63	60	80	27	11	15	23	40	60	55	23	R20	16	+0.027 0	M10 x 25	ø63 double clevis type	
80	75	100	31	13	16	26	45	67	65	28	R22	18	+0.027 0	M12 x 28	ø80 double clevis type	
100	90	118	35	13	17	30	50	74	80	28	R24	20	+0.033 0	M12 x 32	ø100 double clevis type	
125	112	140	41	15	20	30	55	81	90	31	R26	22	+0.033 0	M14 x 36	ø125 double clevis type	
160	140	174	54	17	22	40	65	95	100	34	R30	25	+0.033 0	M16 x 40	ø160 double clevis type	

Note) Does not come with other accessories.

### Knuckle pin

Material: Carbon steel

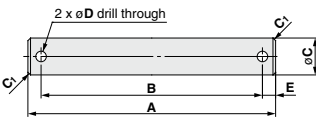

Bore size (mm)	A	B	C (f8)		D	E	Flat washer	Cotter pin	Applicable cylinder type	Order no.
			Size	Tolerance						
40	51.5	41.5	13	+0.016 -0.043	3	5	Polished round 12SPCC	ø3 x 18 $\times$ SWRM	ø40 all types	AC-D1- bore size
50	54.5	44.5	13	+0.016 -0.043	3	5	Polished round 14SPCC	ø3 x 18 $\times$ SWRM	ø50 all types	
63	64.5	54.5	16	+0.016 -0.043	4	5	Polished round 16SPCC	ø4 x 22 $\times$ SWRM	ø63 all types	
80	71.5	61.5	16	+0.016 -0.043	4	5	Polished round 18SPCC	ø4 x 22 $\times$ SWRM	ø80 all types	
100	82	72	20	+0.020 -0.053	5	5	Polished round 20SPCC	ø5 x 30 $\times$ SWRM	ø100, ø125 all types	
125	90	80	20	+0.020 -0.053	5	5	Polished round 22SPCC	ø5 x 30 $\times$ SWRM	ø125, ø160 all types	
160	94	79	20	+0.020 -0.053	5	7.5	Polished round 22SPCC	ø5 x 30 $\times$ SWRM	ø160 all types	

Note) Does not come with other accessories.

### Knuckle

Material: Carbon steel

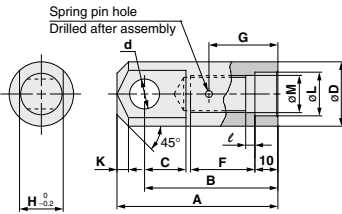

Bore size (mm)	A	B	C	D	d (H8)		E	F	Pitch G	H	K	L (F8)		M	N	P	Spring pin	Applicable cylinder type	Order no.
					Size	Tolerance						Size	Tolerance						
40	67	55	15	25	13	+0.027 0	M14 x 1.5	26	28	17	4	17	+0.043 -0.016	142	4	3 x 25AW	ø40 all types	AC-B1- bore size	
50	70	58	18	28	13	+0.027 0	M16 x 1.5	28	30	19	5	19	+0.053 -0.020	162	4	3 x 28AW	ø50 all types		
63	80	65	20	30	16	+0.027 0	M18 x 1.5	32	32	22	6	21	+0.053 -0.020	183	4	4 x 28AW	ø63 all types		
80	95	78	22	35	16	+0.027 0	M22 x 1.5	40	36	27	7	26	+0.053 -0.020	223	4	4 x 36AW	ø80 all types		
100	110	90	26	42	20	+0.033 0	M27 x 2	45	40	32	8	34	+0.064 -0.025	275	5	5 x 40AW	ø100, ø125 all types		
125	120	100	30	50	22	+0.033 0	M33 x 2	50	44	36	10	43	+0.064 -0.025	34	5	5 x 50AW	ø160 all types		
160	120	100	30	50	22	+0.033 0	M33 x 2	50	44	36	10	43	+0.064 -0.025	34	5	5 x 50AW	ø160 all types		

### Y-type knuckle

Material: Carbon steel

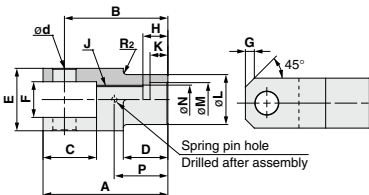

Bore size (mm)	A	B	C	D	d (H8)		E	F	G	H	J	K	L		M	N	P	Spring pin	Applicable cylinder type	Order no.
					Size	Tolerance							Size	Tolerance						
40	67	55	27	19	13	+0.027 0	32	18	+0.2 0	4	14	M14 x 1.5	10	25	+0.053 +0.020	142	28	3 x 25 AW	ø40 all types	AC-Y1- bore size
50	70	58	30	25	13	+0.027 0	35	20	+0.2 0	5	14	M16 x 1.5	10	28	+0.053 +0.020	162	30	3 x 28 AW	ø50 all types	
63	80	65	35	30	16	+0.027 0	43	23	+0.2 0	6	14	M18 x 1.5	10	31	+0.053 +0.020	183	32	4 x 28 AW	ø63 all types	
80	95	78	39	35	16	+0.027 0	50	28	+0.2 0	7	14	M22 x 1.5	10	35	+0.053 +0.020	223	36	4 x 36 AW	ø80 all types	
100	110	90	45	43	20	+0.033 0	59	33	+0.2 0	8	15	M27 x 2	10	42	+0.064 +0.025	275	40	5 x 40 AW	ø100, ø125 all types	
125	120	100	50	45	22	+0.033 0	66	37	+0.2 0	10	15	M33 x 2	10	50	+0.064 +0.025	34	44	5 x 50 AW	ø160 all types	
160	120	100	50	45	22	+0.033 0	66	37	+0.2 0	10	15	M33 x 2	10	50	+0.064 +0.025	34	44	5 x 50 AW	ø160 all types	

# Tie-rod Type Hydraulic Cylinder Double Acting/Single Rod **CHA Series**

## Rod end nut

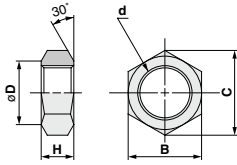

							(mm)
Bore size (mm)	B	C	D	d	H	Applicable cylinder type	Order no.
40	22	25.4	21	M14×1.5	8	ø40all types	AC-N1- bore size
50	24	27.7	23	M16×1.5	10	ø50all types	
63	27	31.2	26	M18×1.5	11	ø63all types	
80	32	37	31	M22×1.5	13	ø80all types	
100	41	47.3	39	M27×2	16	ø100, ø125all types	
160	50	57.7	48	M33×2	20	ø160all types	

**CHQ**

**CHK**

**CHN**

**CHM**

**CHS**

**CH2**

**CHA**

Related Products

**D-**

# CHA Series Auto Switch Mounting

Refer to pages 431 to 490 for detailed specifications.

## Auto Switches: Proper Mounting Positions and Mounting Heights for Stroke End Detection

### <Tie-rod mount type>

D-M9□/M9□V  
D-M9□W/M9□WV  
D-M9□A/M9□AV  
D-A9□/A9□V

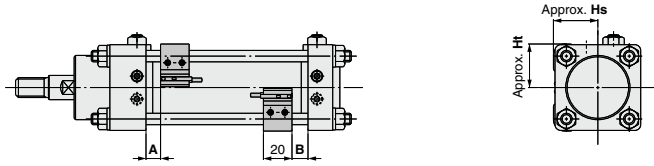

D-F5□/J59  
D-F5NT  
D-F5□W/J59W  
D-F5BA/F59F  
D-A5□/A6□  
D-A59W

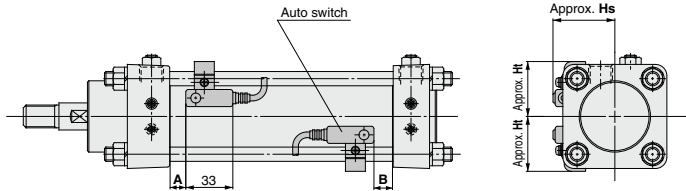

### <Band mount type>

D-G39/K39  
D-A3□

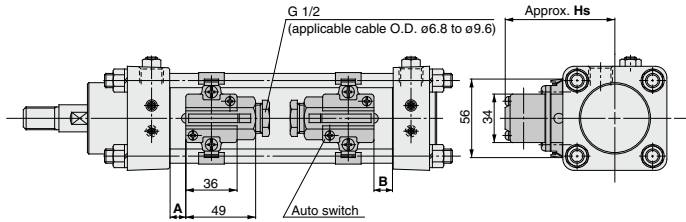

D-A44

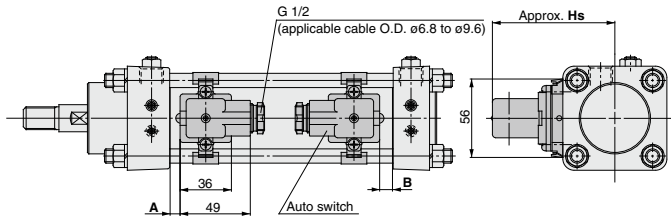

D-B5□/B6□

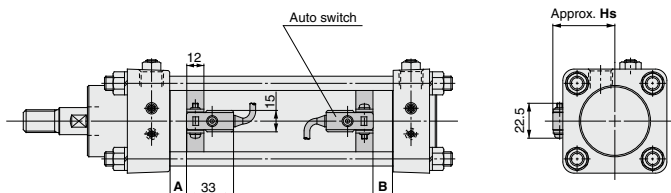



**Auto Switch Proper Mounting Positions**

(mm)

Bore size (mm)	D-M9□/M9□V D-M9□WM9□WV D-M9□AM9□AV		D-F5□/J59 D-F5□W/J59W D-F59F/F5BA		D-F5NT		D-G5□/K59 D-G5□W/K59W D-G59F/G5BA D-G5NT		D-G39□/K39□		D-A9□/A9□V		D-A5□/A6□		D-A59W		D-B5□/B64		D-B59W		D-A3□/A44	
	A	B	A	B	A	B	A	B	A	B	A	B	A	B	A	B	A	B	A	B	A	B
<b>40</b>	20.5	21.5	17	18	22	23	12.5	13.5	10.5	11.5	16.5	17.5	10.5	11.5	14.5	15.5	11	12	13.5	15	10.5	11.5
<b>50</b>	21	23	17.5	19.5	22.5	24.5	13	15	11	13	17	19	11	13	15	17	11.5	13.5	14	16.5	11	13
<b>63</b>	23.5	24.5	20	21	25	26	—	—	13.5	14.5	19.5	20.5	13.5	14.5	17.5	18.5	—	—	—	—	13.5	14.5
<b>80</b>	23.5	26.5	20	23	25	28	15.5	18.5	13.5	16.5	19.5	22.5	13.5	16.5	17.5	20.5	14	17	16.5	20	13.5	16.5
<b>100</b>	27	31	23.5	27.5	28.5	32.5	19	23	17	21	23	27	17	21	21	25	17.5	21.5	20	24.5	17	21

Note 1) The auto switches listed below cannot be mounted on ø63.  
 D-G5□, K59, G5□W, K59W, G5BA, G59F, G5NT, B5□, B64, and B59W  
 Note 2) Adjust the auto switch after confirming the operating conditions in the actual setting.

**Auto Switch Mounting Heights**

(mm)

Bore size (mm)	D-M9□/M9□W D-A9□A D-A9□		D-M9□V/M9□WV D-M9□AV D-A9□V		D-F5□/J59 D-F5□W/J59W D-F59F/F5BA D-F5NT		D-A5□/A6□ D-A59W		D-G5□/K59 D-G5□W/K59W D-G59F/G5BA D-G5NT D-B5□/B64 D-B59W		D-G39□/K39□ D-A3□		D-A44	
	Hs	Ht	Hs	Ht	Hs	Ht	Hs	Ht	Hs	Ht	Hs	Ht	Hs	Ht
<b>40</b>	31	31	36	31	38	33.5	39.5	33.5	38	72.5	82.5			
<b>50</b>	36.5	36.5	40	36.5	43	39	44	39	43.5	78	88			
<b>63</b>	40	40	45	40	48.5	43	50	43	—	85	95			
<b>80</b>	50	50	55.5	50	56	51	57	51	59	93.5	104			
<b>100</b>	59	59	63	59	63.5	58.5	65	58.5	70	104	114			

\* The auto switches listed below cannot be mounted on ø63.  
 D-G5□, K59, G5□W, K59W, G5BA, G59F, G5NT, B5□, B64, and B59W

**Operating Range**

(mm)

Auto switch model	Bore size				
	40	50	63	80	100
D-M9□/M9□V D-M9□W/M9□WV D-M9□A/M9□AV	3.5	3.5	5	4.5	5.5
D-F5□/J59/F59F D-F5□W/J59W D-F5BA/F5NT	4.5	4	4.5	4.5	4.5
D-G5□/K59/G59F D-G5□W/K59W D-G5BA/G5NT	5	5	—	6.5	6.5
D-G39/K39	9.5	9.5	10	10	10
D-A9□/A9□V	7.5	8	8.5	9	9
D-A5□/A6□	9	9	9.5	9.5	9.5
D-A59W	13.5	13.5	14	14	14
D-B5□/B64	11.5	12	—	13.5	14.5
D-B59W	12	12.5	—	14.5	15
D-A3□/A44	10	10	11.5	11.5	12

\* The auto switches listed below cannot be mounted on ø63.  
 D-G5□, K59, G5□W, K59W, G5BA, G59F, G5NT, B5□, B64, and B59W  
 \* Since this is a guideline including hysteresis, not meant to be guaranteed. (Assuming approximately ±30% dispersion.)  
 There may be the case it will vary substantially depending on an ambient environment.

CHK

CHK□

CHN

CHM

CHS□

CH2□

CHA

Related Products

D-□

## Minimum Strokes for Auto Switch Mounting

n: Number of auto switches

Auto switch types	Number of auto switches	Mounting brackets other than center trunnion	Center trunnion type				
			ø40	ø50	ø63	ø80	ø100
D-M9□/M9□W	1 or 2 pcs. (different surfaces/same surface)	15	80	80	85	90	95
	"n" pcs. (same surface)	$15 + 40 \frac{(n-2)}{2}$ (n = 2, 4, 6, 8 ...) <sup>Note 1)</sup>	$80 + 40 \frac{(n-4)}{2}$ (n = 4, 8, 12, 16 ...) <sup>Note 2)</sup>	$80 + 40 \frac{(n-4)}{2}$ (n = 4, 8, 12, 16 ...) <sup>Note 2)</sup>	$85 + 40 \frac{(n-4)}{2}$ (n = 4, 8, 12, 16 ...) <sup>Note 2)</sup>	$90 + 40 \frac{(n-4)}{2}$ (n = 4, 8, 12, 16 ...) <sup>Note 2)</sup>	$95 + 40 \frac{(n-4)}{2}$ (n = 4, 8, 12, 16 ...) <sup>Note 2)</sup>
D-M9□V/M9□WV	1 or 2 pcs. (different surfaces/same surface)	10	55	55	60	65	70
	"n" pcs. (same surface)	$10 + 30 \frac{(n-2)}{2}$ (n = 2, 4, 6, 8 ...) <sup>Note 1)</sup>	$55 + 30 \frac{(n-4)}{2}$ (n = 4, 8, 12, 16 ...) <sup>Note 2)</sup>	$55 + 30 \frac{(n-4)}{2}$ (n = 4, 8, 12, 16 ...) <sup>Note 2)</sup>	$60 + 30 \frac{(n-4)}{2}$ (n = 4, 8, 12, 16 ...) <sup>Note 2)</sup>	$65 + 30 \frac{(n-4)}{2}$ (n = 4, 8, 12, 16 ...) <sup>Note 2)</sup>	$70 + 30 \frac{(n-4)}{2}$ (n = 4, 8, 12, 16 ...) <sup>Note 2)</sup>
D-M9□A	1 or 2 pcs. (different surfaces/same surface)	15	85	85	90	95	100
	"n" pcs. (same surface)	$15 + 40 \frac{(n-2)}{2}$ (n = 2, 4, 6, 8 ...) <sup>Note 1)</sup>	$85 + 40 \frac{(n-4)}{2}$ (n = 4, 8, 12, 16 ...) <sup>Note 2)</sup>	$85 + 40 \frac{(n-4)}{2}$ (n = 4, 8, 12, 16 ...) <sup>Note 2)</sup>	$90 + 40 \frac{(n-4)}{2}$ (n = 4, 8, 12, 16 ...) <sup>Note 2)</sup>	$95 + 40 \frac{(n-4)}{2}$ (n = 4, 8, 12, 16 ...) <sup>Note 2)</sup>	$100 + 40 \frac{(n-4)}{2}$ (n = 4, 8, 12, 16 ...) <sup>Note 2)</sup>
D-M9□AV	1 or 2 pcs. (different surfaces/same surface)	15	60	65	65	75	75
	"n" pcs. (same surface)	$15 + 30 \frac{(n-2)}{2}$ (n = 2, 4, 6, 8 ...) <sup>Note 1)</sup>	$60 + 30 \frac{(n-4)}{2}$ (n = 4, 8, 12, 16 ...) <sup>Note 2)</sup>	$65 + 30 \frac{(n-4)}{2}$ (n = 4, 8, 12, 16 ...) <sup>Note 2)</sup>	$65 + 30 \frac{(n-4)}{2}$ (n = 4, 8, 12, 16 ...) <sup>Note 2)</sup>	$75 + 30 \frac{(n-4)}{2}$ (n = 4, 8, 12, 16 ...) <sup>Note 2)</sup>	$75 + 30 \frac{(n-4)}{2}$ (n = 4, 8, 12, 16 ...) <sup>Note 2)</sup>
D-A9□	1 or 2 pcs. (different surfaces/same surface)	15	75	75	80	85	90
	"n" pcs. (same surface)	$15 + 40 \frac{(n-2)}{2}$ (n = 2, 4, 6, 8 ...) <sup>Note 1)</sup>	$75 + 40 \frac{(n-4)}{2}$ (n = 4, 8, 12, 16 ...) <sup>Note 2)</sup>	$75 + 40 \frac{(n-4)}{2}$ (n = 4, 8, 12, 16 ...) <sup>Note 2)</sup>	$80 + 40 \frac{(n-4)}{2}$ (n = 4, 8, 12, 16 ...) <sup>Note 2)</sup>	$85 + 40 \frac{(n-4)}{2}$ (n = 4, 8, 12, 16 ...) <sup>Note 2)</sup>	$90 + 40 \frac{(n-4)}{2}$ (n = 4, 8, 12, 16 ...) <sup>Note 2)</sup>
D-A9□V	1 or 2 pcs. (different surfaces/same surface)	10	50	50	55	60	65
	"n" pcs. (same surface)	$10 + 30 \frac{(n-2)}{2}$ (n = 2, 4, 6, 8 ...) <sup>Note 1)</sup>	$50 + 30 \frac{(n-4)}{2}$ (n = 4, 8, 12, 16 ...) <sup>Note 2)</sup>	$50 + 30 \frac{(n-4)}{2}$ (n = 4, 8, 12, 16 ...) <sup>Note 2)</sup>	$55 + 30 \frac{(n-4)}{2}$ (n = 4, 8, 12, 16 ...) <sup>Note 2)</sup>	$60 + 30 \frac{(n-4)}{2}$ (n = 4, 8, 12, 16 ...) <sup>Note 2)</sup>	$65 + 30 \frac{(n-4)}{2}$ (n = 4, 8, 12, 16 ...) <sup>Note 2)</sup>
D-A5□, A6□ D-F5□, J59	1 or 2 pcs. (different surfaces/same surface)	10	100	100	100	110	120
	"n" pcs. (same surface)	$10 + 55 \frac{(n-2)}{2}$ (n = 2, 4, 6, 8 ...) <sup>Note 1)</sup>	$100 + 55 \frac{(n-4)}{2}$ (n = 4, 8, 12, 16 ...) <sup>Note 2)</sup>	$100 + 55 \frac{(n-4)}{2}$ (n = 4, 8, 12, 16 ...) <sup>Note 2)</sup>	$100 + 55 \frac{(n-4)}{2}$ (n = 4, 8, 12, 16 ...) <sup>Note 2)</sup>	$110 + 55 \frac{(n-4)}{2}$ (n = 4, 8, 12, 16 ...) <sup>Note 2)</sup>	$120 + 55 \frac{(n-4)}{2}$ (n = 4, 8, 12, 16 ...) <sup>Note 2)</sup>
D-A59W	2 pcs. (different surfaces/same surface)	20	100	100	100	110	120
	"n" pcs. (same surface)	$20 + 55 \frac{(n-2)}{2}$ (n = 2, 4, 6, 8 ...) <sup>Note 1)</sup>	$100 + 55 \frac{(n-4)}{2}$ (n = 4, 8, 12, 16 ...) <sup>Note 2)</sup>	$100 + 55 \frac{(n-4)}{2}$ (n = 4, 8, 12, 16 ...) <sup>Note 2)</sup>	$100 + 55 \frac{(n-4)}{2}$ (n = 4, 8, 12, 16 ...) <sup>Note 2)</sup>	$110 + 55 \frac{(n-4)}{2}$ (n = 4, 8, 12, 16 ...) <sup>Note 2)</sup>	$120 + 55 \frac{(n-4)}{2}$ (n = 4, 8, 12, 16 ...) <sup>Note 2)</sup>
	1 pc.	15	100	100	100	110	120
D-F5□W, J59W D-F5BA D-F59F D-F5NT	1 or 2 pcs. (different surfaces/same surface)	15	120	120	120	130	140
	"n" pcs. (same surface)	$15 + 55 \frac{(n-2)}{2}$ (n = 2, 4, 6, 8 ...) <sup>Note 1)</sup>	$120 + 55 \frac{(n-4)}{2}$ (n = 4, 8, 12, 16 ...) <sup>Note 2)</sup>	$120 + 55 \frac{(n-4)}{2}$ (n = 4, 8, 12, 16 ...) <sup>Note 2)</sup>	$120 + 55 \frac{(n-4)}{2}$ (n = 4, 8, 12, 16 ...) <sup>Note 2)</sup>	$130 + 55 \frac{(n-4)}{2}$ (n = 4, 8, 12, 16 ...) <sup>Note 2)</sup>	$140 + 55 \frac{(n-4)}{2}$ (n = 4, 8, 12, 16 ...) <sup>Note 2)</sup>
D-B5□, B64	2 pcs.	Different surfaces	15	90	—	—	120
		Same surface	75	90	—	—	120
	"n" pcs.	Different surfaces	$15 + 50 \frac{(n-2)}{2}$ (n = 2, 4, 6, 8 ...) <sup>Note 1)</sup>	$90 + 50 \frac{(n-4)}{2}$ (n = 4, 8, 12, 16 ...) <sup>Note 2)</sup>	—	—	$120 + 50 \frac{(n-4)}{2}$ (n = 4, 8, 12, 16 ...) <sup>Note 2)</sup>
		Same surface	$75 + 50 (n-2)$ (n = 2, 3, 4 ...)	$90 + 50 (n-2)$ (n = 2, 4, 6, 8 ...) <sup>Note 1)</sup>	—	—	$120 + 50 (n-2)$ (n = 2, 4, 6, 8 ...) <sup>Note 1)</sup>
	1 pc.	10	90	—	—	120	
D-B59W	2 pcs.	Different surfaces	20	90	—	—	120
		Same surface	75	90	—	—	120
	"n" pcs.	Different surfaces	$20 + 50 \frac{(n-2)}{2}$ (n = 2, 4, 6, 8 ...) <sup>Note 1)</sup>	$90 + 50 \frac{(n-4)}{2}$ (n = 4, 8, 12, 16 ...) <sup>Note 2)</sup>	—	—	$120 + 50 \frac{(n-4)}{2}$ (n = 4, 8, 12, 16 ...) <sup>Note 2)</sup>
		Same surface	$75 + 50 (n-2)$ (n = 2, 3, 4 ...)	$90 + 50 (n-2)$ (n = 2, 4, 6 ...) <sup>Note 1)</sup>	—	—	$120 + 50 (n-2)$ (n = 2, 4, 6, 8 ...) <sup>Note 1)</sup>
	1 pc.	15	90	—	—	120	
D-A3□ D-G39 D-K39	2 pcs.	Different surfaces	35	75	80	90	90
		Same surface	55	75	80	90	90
	"n" pcs.	Different surfaces	$35 + 30 (n-2)$ (n = 2, 3, 4 ...)	$75 + 30 (n-2)$ (n = 2, 4, 6, 8 ...)	$80 + 30 (n-2)$ (n = 2, 4, 6, 8 ...)	$90 + 30 (n-2)$ (n = 2, 4, 6, 8 ...)	$90 + 30 (n-2)$ (n = 2, 4, 6, 8 ...)
		Same surface	$100 + 100 (n-2)$ (n = 2, 3, 4 ...)	—	$100 + 100 (n-2)$ (n = 2, 4, 6, 8 ...)	—	—
	1 pc.	10	75	80	90	90	
D-A44	2 pcs.	Different surfaces	35	75	80	90	90
		Same surface	55	75	80	90	90
	"n" pcs.	Different surfaces	$35 + 30 (n-2)$ (n = 2, 3, 4 ...)	$75 + 30 (n-2)$ (n = 2, 4, 6, 8 ...)	$80 + 30 (n-2)$ (n = 2, 4, 6, 8 ...)	$90 + 30 (n-2)$ (n = 2, 4, 6, 8 ...)	$90 + 30 (n-2)$ (n = 2, 4, 6, 8 ...)
		Same surface	$55 + 50 (n-2)$ (n = 2, 3, 4 ...)	$75 + 50 (n-2)$ (n = 2, 4, 6, 8 ...)	$80 + 50 (n-2)$ (n = 2, 4, 6, 8 ...)	$90 + 50 (n-2)$ (n = 2, 4, 6, 8 ...)	$90 + 50 (n-2)$ (n = 2, 4, 6, 8 ...)
	1 pc.	10	75	80	90	90	

Note 1) When "n" is an odd number, an even number that is one larger than this odd number is used for the calculation.  
 Note 2) When "n" is an odd number, a multiple of 4 that is larger than this odd number is used for the calculation.

**Auto Switch Mounting Brackets: Part Nos.**

**<Tie-rod mounting>**

Auto switch models	Bore size (mm)				
	ø40	ø50	ø63	ø80	ø100
D-M9□/M9□V/M9□W/M9□WV D-M9□A/M9□AV/A9□/A9□V	BA7-040	BA7-063	BA7-063	BA7-080	BA7-080
D-F5□/J59/F5□W/J59W D-F5BA/F59F/F5NT D-A5□/A6□/A59W	BT-04	BT-06	BT-06	BT-08	BT-08

**<Band mounting>**

Auto switch models	Bore size (mm)				
	ø40	ø50	ø63	ø80	ø100
D-G39/K39/A3□/A44	BD1-04M	BD1-05M	BD1-06M	BD1-08M	BD1-10M
D-G5□/K59 D-G5□W/K59W/G5BA/G59F D-G5NT/B5□/B64/B59W	BA-04	BA-05	—	BA-08	BA-10

Note 1) The auto switches listed below cannot be mounted on ø63.  
D-G5□, K59, G5□W, K59W, G5BA, G59F, G5NT, B5□, B64, and B59W

**[Stainless steel mounting screw kits]**

The following stainless steel mounting screw kits are available for use depending on the operating environment. (Switch mounting bands are not included and should be ordered separately.)

- BBA1 : D-F5, J5, A5, A6
- BBA3 : D-G5, K5, B5, B6

Note 2) Refer to the table below for details on BBA1, BBA3.

**Stainless mounting screw kit details**

Part no.	Contents				Applicable auto switch mounting bracket part nos.	Applicable auto switches
	No.	Description	Size	Pcs.		
BBA1	1	Auto switch mounting screws	M4 x 0.7 x 8L	1	BT-□□ BT-03, BT-04, BT-05 BT-06, BT-08, BT-12	D-A5, A6 D-F5, J5
	2	Set screw	M4 x 0.7 x 6L	2	BA4-040, BA4-063, BA4-080 BMB4-032, BMB4-050 BMB5-032 BA7-040, BA7-063, BA7-080	D-Z7, Z8 D-Y5, Y6, Y7 D-A9 D-M9
	3	Set screw	M4 x 0.7 x 8L	2	BT-16, BT-18A, BT-20 BS4-125, BS4-160 BS4-180, BS4-200 BS5-125, BS5-160 BS5-180, BS5-200	D-A5, A6 D-F5, J5 D-Z7, Z8 D-Y5, Y6, Y7 D-A9 D-M9
BBA3	4	Auto switch mounting screws	M4 x 0.7 x 22L	1	BA-01, BA-02, BA-32, BA-04 BA-05, BA-06, BA-08, BA-10 BA2-020, BA2-025 BA2-032, BA2-040 BA5-050, BHN2-025, BSG1-032 BH2-040, BH2-050 BH2-080, BH2-100 BAF-32, BAF-04, BAF-05 BAF-06, BAF-08, BAF-10	D-B5, B6 D-G5, K5

When D-F5BA and G5BA auto switches are shipped mounted on a cylinder, the above stainless steel screws are used. Also when switches are shipped separately, BBA1, BBA3 are included.

Note 3) When using D-M9□A(V), order stainless mounting screw kit BBA1 instead of the iron auto switch mounting brackets (BA7-□□□, BS5-□□□) in the table above, and use the M4 x 6L stainless set screws included.

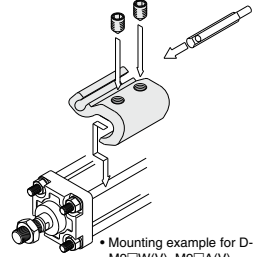

• Mounting example for D-M9□(V), M9□W(V), M9□A(V).

- CHA
- CHK□
- CHN
- CHM
- CHS□
- CH2□
- CHA
- Related Products
- D-□

Besides the models listed in "How to Order," the following auto switches are applicable. Refer to pages 431 to 490 for detailed auto switch specifications.

Auto switch type	Part no.	Electrical entry	Features
Solid state	D-M9NV, M9PV, M9BV	Grommet (perpendicular)	—
	D-M9NVW, M9PWV, M9BWW		Diagnostic indication (2-color indicator)
	D-M9NAV, M9PAV, M9BAV		Water resistant (2-color indicator)
	D-F59, F5P, J59	Grommet (in-line)	—
	D-F59W, F5PW, J59W		Diagnostic indication (2-color indicator)
	D-F5BA		Water resistant (2-color indicator)
Reed	D-F5NT, G5NT	Grommet (perpendicular)	With timer
	D-A93V, A96V		—
	D-A90V		Without indicator light
	D-A53, A56, B53		—
	D-A67		Without indicator light

\* Solid state auto switches are also available with pre-wired connector. Refer to pages 474 and 475 for details.  
\* Normally closed (N.C. = b contact), solid state auto switches (D-F9G, F9H) are also available. For details, refer to page 443.

## How to Mount and Move the Auto Switch

### <Applicable auto switch>

Solid state ..... D-M9N(V), D-M9P(V), D-M9B(V)  
 D-M9NW(V), D-M9PW(V), D-M9BW(V)  
 D-M9NA(V), D-M9PA(V), D-M9BA(V)

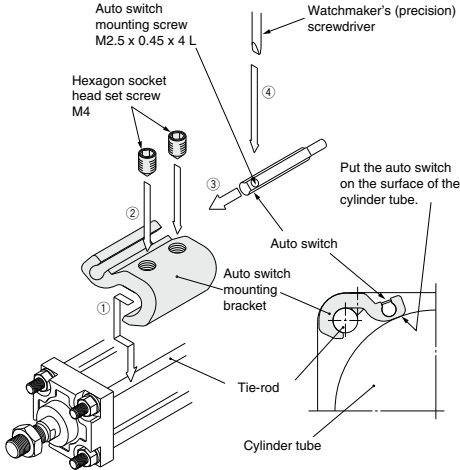

1. Fix it to the detecting position with a set screw by installing an auto switch mounting bracket in cylinder tie-rod and letting the bottom surface of an auto switch mounting bracket contact the cylinder tube firmly.
2. Fix it to the detecting position with a hexagon socket head set screw (M4).  
(Use a hexagon wrench.)
3. Fit an auto switch into the auto switch mounting groove to set it roughly to the mounting position for an auto switch.
4. After confirming the detecting position, tighten up the mounting screw (M2.5) attached to an auto switch, and secure the auto switch.
5. When changing the detecting position, carry out in the state of 3.

Note 1) To protect auto switches, ensure that main body of an auto switch should be embedded into auto switch mounting groove with a depth of 15 mm or more.

Note 2) Set the tightening torque of a hexagon socket head set screw (M4) to be 1 to 1.2 N·m.

Note 3) When tightening an auto switch mounting screw (M2.5), use a watchmaker's screwdriver with a grip diameter of 5 to 6 mm.  
 Also, set the tightening torque to be 0.05 to 0.15 N·m. As a guide, turn 90° from the position where it comes to feel tight.

### <Applicable auto switch>

Solid state ..... D-F59, D-F5P  
 D-J59, D-F5BA  
 D-F59W, D-F5PW, D-J59W  
 D-F59F, D-F5NT  
 Reed ..... D-A53, D-A54, D-A56, D-A64, D-A67  
 D-A59W

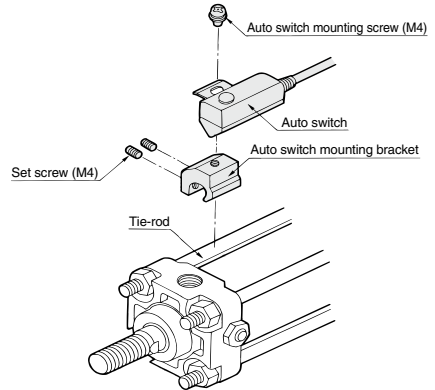

1. Fix the auto switch on the auto switch mounting bracket with the auto switch mounting screw (M4) and install the set screw.
2. Fit the auto switch mounting bracket into the cylinder tie-rod and then fix the auto switch at the detecting position with the hexagonal wrench. (Be sure to put the auto switch on the surface of cylinder tube.)
3. When changing the detecting position, loosen the set screw to move the auto switch and then re-fix the auto switch on the cylinder tube. (Tightening torque of M4 screw should be 1 to 1.2 N·m.)



## 1 Fluororubber Seals

Symbol

**-XC22**

### How to Order

Standard model no. **-XC22**

Fluororubber seals

### Specifications

Seal material	Fluororubber
Ambient temperature range	Note 1) With auto switch : -10 to 60 Without auto switch : -10 to 80
Specifications other than above and external dimensions	Same as standard type

Note 1) Please confirm with SMC, as the type of chemical and the operating temperature may not allow the use of this product.

Note 2) Cylinders with auto switches can also be produced; however, auto switch related parts (auto switch units, mounting brackets, built-in magnets) are the same as standard products. Before using these, please contact SMC regarding their suitability for the operating environment.

CHQ

CHK

CHN

CHM

CHS

CHZ

**CHA**

Related Products

D-

# Tie-rod Type Hydraulic Cylinder Double Acting/Double Rod

# CHAW Series

3.5 MPa

∅40, ∅50, ∅63, ∅80, ∅100, ∅125, ∅160

## How to Order

**Without Auto Switch** CHAW L [ ] 40 - 100 [ ] [ ]

**With Auto Switch** CHDAW L [ ] 40 - 100 [ ] - M9BW [ ] [ ]

**Tube material**

Nil	Aluminum alloy
F	Steel tube

**Bore size**

40	40 mm	Aluminum tube Steel tube
50	50 mm	
63	63 mm	
80	80 mm	
100	100 mm	
125	125 mm	
160	160 mm	

**Auto switch type**

Nil	Without auto switch
-----	---------------------

\* Select applicable auto switch models from the table below.

**Built-in magnet**

**Mounting type**

B	Basic type
L	Axial foot type
F	Rod flange type
T	Center trunnion type
U	Rod trunnion type

**Bore size**

40	40 mm	Aluminum tube Steel tube
50	50 mm	
63	63 mm	
80	80 mm	
100	100 mm	

**Number of auto switches**

Nil	2 pcs.
S	1 pc.
3	3 pcs.
n	"n" pcs.

**Cylinder stroke (mm)**

Refer to the standard stroke table on page 417.

**Cylinder option**

Cushion	Nil	Both sides
	N	Without cushion
	R	With rod cushion
	H	With head cushion

**Built-in Magnet Cylinder Model**

If a built-in magnet cylinder without auto switch is required, there is no need to enter the symbol for the auto switch.  
(Example) CHDAWB50-100□

## Applicable Auto Switches

Refer to pages 431 to 490 for further details on each auto switch.

Type	Special function	Electrical entry	Indicator light	Wiring (output)	Load voltage		Auto switch model		Lead wire length (m)					Pre-wired connector	Applicable load						
					DC	AC	Tie-rod mount	Band mount	0.5 (Nil)	1 (M)	3 (L)	5 (Z)	None								
																3-wire (NPN)	3-wire (PNP)	2-wire	3-wire (NPN)	3-wire (PNP)	2-wire
Solid state auto switch	—	Grommet	Yes	3-wire (NPN)	24 V	5 V, 12 V	—	M9N	G59**	●	●	○	○	○	○	IC circuit	Relay PLC				
				3-wire (PNP)				M9P	G5P**	●	●	○	○	○	○						
				2-wire				M9B	K59**	●	●	○	○	○	○						
		3-wire (NPN)		—				K39	●	●	○	○	○	○	IC circuit						
		2-wire		—				K39	●	●	○	○	○	○							
		3-wire (PNP)		—				—	●	●	○	○	○	○	○						
	Diagnostic indication (2-color indicator)	Terminal conduit	Yes	3-wire (NPN)	24 V	5 V, 12 V	—	M9NW	G59W**	●	●	○	○	○	○	IC circuit					
				3-wire (PNP)				M9PW	G5PW**	●	●	○	○	○	○						
				2-wire				M9BW	K59W**	●	●	○	○	○	○						
				3-wire (NPN)				—	—	●	●	○	○	○	○						
Water resistant (2-color indicator)	Grommet	Yes	3-wire (PNP)	24 V	5 V, 12 V	—	M9NA*1	—	○	○	○	○	○	○	IC circuit						
			3-wire (NPN)				M9PA*1	—	○	○	○	○	○	○							
			2-wire				M9BA*1	—	○	○	○	○	○	○							
			3-wire (PNP)				—	—	○	○	○	○	○	○							
			2-wire				—	—	○	○	○	○	○	○							
			3-wire (NPN)				—	—	○	○	○	○	○	○							
Diagnostic output (2-color indicator)	Terminal conduit	Yes	4-wire (NPN)	24 V	5 V, 12 V	—	F59F	G59F**	●	●	○	○	○	○	IC circuit						
			3-wire (NPN) equiv.				—	—	○	○	○	○	○	○							
Reed auto switch	—	Grommet	Yes	2-wire	24 V	12 V	—	A96	—	●	●	○	○	○	IC circuit	Relay PLC					
								A93	—	●	●	○	○	○							
								A90	—	●	●	○	○	○							
								A54	B54**	●	●	○	○	○							
								A64	B64**	●	●	○	○	○							
		Terminal conduit		Yes				2-wire	24 V	12 V	—	—	A33	—	○		○	○	○	○	—
													A34	—	○		○	○	○	○	
													A44	—	○		○	○	○	○	
													—	—	○		○	○	○	○	
													—	—	○		○	○	○	○	
Diagnostic indication (2-color indicator)	Grommet	Yes	2-wire	24 V	—	—	A59W	B59W**	●	●	○	○	○	IC circuit							

\*1 Water resistant type auto switches can be mounted on the above models, but in such case SMC cannot guarantee water resistance. Consult with SMC regarding water resistant types with the above model numbers.

\* Lead wire length symbols: 0.5 m ..... Nil (Example) M9NW  
1 m ..... M (Example) M9NWM  
3 m ..... L (Example) M9NWL  
5 m ..... Z (Example) M9NWZ

\* Solid state auto switches marked "○" are produced upon receipt of order.  
\*\* Types D-G5□, K59, G5□W, K59W, G5BA, G59F, G5NT, B5□, B64, and B59W cannot be mounted on ∅63 bore size cylinders.

\* Since there are applicable auto switches other than listed, refer to page 413 for details.

\* For details about auto switches with pre-wired connector, refer to pages 474 and 475.

\* D-A9□, M9□, M9□W, M9□A auto switches are shipped together (not assembled). (Only auto switch mounting brackets are packed assembled.)

# Tie-rod Type Hydraulic Cylinder Double Acting/Double Rod **CHAW Series**

## Light

Principle parts are light weight aluminum alloy.

## Easy position detection: with auto switches

Aluminum cylinder sizes  $\phi 40$  to  $\phi 100$  are auto switch capable for easy stroke position detection.

## Smooth cushioning

Cushioning nearly equal to a shock absorber is achieved with a unique cushion ring configuration and cushion seal design.



Specifications with included auto switch are the same for Double Acting/Single Rod. Refer to pages 410 to 414.

- Minimum Strokes for Auto Switch Mounting
- Auto Switches: Proper Mounting Positions and Mounting Heights for Stroke End Detection
- Operating Range
- Auto Switch Mounting Brackets: Part Nos.

## Models

Model	Tube material	Bore size (mm)
CHAW	Aluminum alloy	40, 50, 63, 80, 100
CHAFW	Steel	40, 50, 63, 80, 100, 125, 160

## Specifications

<b>Action</b>	Double acting/Double rod
<b>Fluid</b>	Hydraulic fluid
<b>Nominal pressure</b>	3.5 MPa
<b>Proof pressure</b>	5.0 MPa
<b>Maximum allowable pressure</b>	3.5 MPa
<b>Minimum operating pressure</b>	0.25 MPa
<b>Ambient and fluid temperature</b>	Without auto switch: $-10^{\circ}$ to $80^{\circ}\text{C}$ With auto switch: $-10^{\circ}$ to $60^{\circ}\text{C}$
<b>Piston speed</b>	8 to 300 mm/s
<b>Cushion</b>	Cushion seal
<b>Stroke length tolerance</b>	to 100st $^{+0.8}_0$ , 100 to 250st $^{+1.0}_0$ , 250 to 630st $^{+1.25}_0$ 630 to 1000st $^{+1.4}_0$ , 1000 to 1200st $^{+1.8}_0$
<b>Mounting</b>	Basic type (B), Axial foot type (L), Rod flange type (F) Center trunnion type (T), Rod trunnion type (U)

Note) Refer to page 214 for definitions of terms related to pressure.

## Standard Strokes

Bore size (mm)	Standard strokes (mm)
40	25 to 800
50	25 to 800
63	25 to 800
80	25 to 1000
100	25 to 1000
125	50 to 1000
160	50 to 1200

Note) Refer to pages 232 and 233 to determine stroke limitation depending on the type of mounting brackets that will be used. Then make your selection.

## Cushion Strokes (For Rod Side and Head Side)

Bore size (mm)	Effective cushion stroke (mm)
40	15
50	15
63	17
80	20
100	20
125	20
160	22

## Hydraulic Fluid Compatibility

Hydraulic fluid	Compatibility
Standard mineral hydraulic fluid	Compatible
W/O hydraulic fluid	Compatible
O/W hydraulic fluid	Compatible
Water/Glycol hydraulic fluid	Not compatible
Phosphate hydraulic fluid	Not compatible

## Accessories (Option)

Knuckle, Y type knuckle, Knuckle pin

Note) Maximum ambient temperature:  
Nylon tarpaulin ( $60^{\circ}\text{C}$ )  
Neoprene cloth ( $110^{\circ}\text{C}$ )

\* Refer to page 408 for part numbers and dimensions.

CHQ

CHN

CHM

CHS

CH2

CHA

Related Products

D-

# CHAW Series

## Weight

### CH□AW Series (Built-in magnet)

Unit: kg

Bore size (mm)		40	50	63	80	100
(0 mm stroke) Basic weight	Basic type	1.44	2.16	2.78	4.58	6.90
	Foot type	1.95	3.08	4.02	6.71	10.34
	Flange type	1.69	2.56	3.35	5.54	8.60
	Rod trunnion type	1.71	2.57	3.28	3.40	9.80
	Center trunnion type	1.86	2.89	3.55	3.67	9.59
	Additional weight per 10 mm stroke	0.1	0.14	0.18	0.24	0.32

Calculation (Example) **CHAWL50-100**

- Basic weight ..... 3.08 (foot type, ø50)
  - Additional weight ..... 0.14/10 mm stroke
  - Cylinder stroke ..... 100 mm
- $3.08 + 0.14 \times 100/10 = 4.48$  kg

### CHAW□F Series

Unit: kg

Bore size (mm)		40	50	63	80	100	125	160
(0 mm stroke) Basic weight	Basic type	1.59	2.27	2.85	5.01	7.49	9.55	16.55
	Foot type	2.10	3.23	4.09	7.14	10.93	16.14	27.25
	Flange type	1.84	2.71	3.42	5.97	9.19	12.51	27.42
	Rod trunnion type	1.86	2.72	3.35	6.77	10.39	14.05	24.39
	Center trunnion type	2.01	2.99	3.62	6.52	10.18	13.31	23.46
	Additional weight per 10 mm stroke	0.18	0.16	0.20	0.38	0.48	0.62	0.94



**Construction**

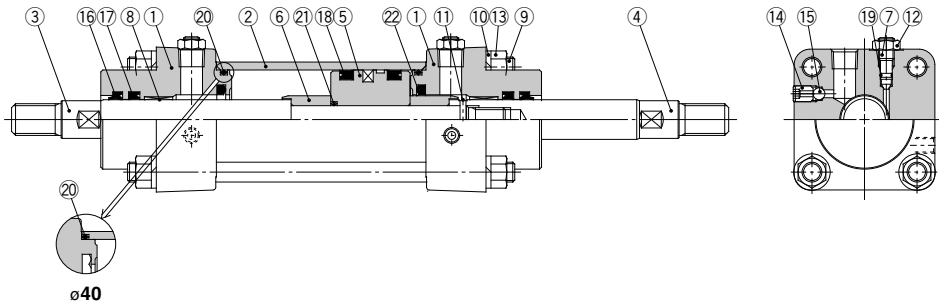

- CHQ**
- CHK
- CHN**
- CHM**
- CHS
- CH2
- CHA**
- Related Products
- D-

**Parts List**

No.	Description	Material	Note
1	Rod cover	Aluminum alloy	70% flat black
2	Cylinder tube	Aluminum alloy Carbon steel	Hard anodized
3	Piston rod A	Carbon steel	Hard chromium electroplated
4	Piston rod B	Carbon steel	Hard chromium electroplated
5	Piston	Aluminum alloy	
6	Cushion ring	Rolled steel	
7	Needle valve	Rolled steel	
8	Bushing	Lead bronze	
9	Tie-rod	Carbon steel	
10	Tie-rod washer	Steel wire	
11	Spring pin	Rolled steel	
12	Needle valve nut	Carbon steel	
13	Tie-rod nut	Carbon steel	
14	Air release valve	Alloy steel	
15	Check ball	Bearing steel	
16	Wiper ring	NBR	
17	Rod seal	NBR	
18	Piston seal	NBR	
19	Needle valve seal	NBR	
20	Cylinder tube gasket	NBR	
21	Piston gasket	NBR	
22	Cushion seal	—	

**Replacement Parts: Seal Kit**

Bore size (mm)	Seal kit no.	Content
40	CHAW40-PS	Nos. 16 through 20 and 22 from the chart at left
50	CHAW50-PS	
63	CHAW63-PS	
80	CHAW80-PS	
100	CHAW100-PS	
125	CHAW125-PS	
160	CHAW160-PS	

\* Seal kit consists of items of 16 through 20 and 22 and can be ordered by using the seal kit number for each bore size.

# CHAW Series

## Dimensions

Basic type: CHAWB

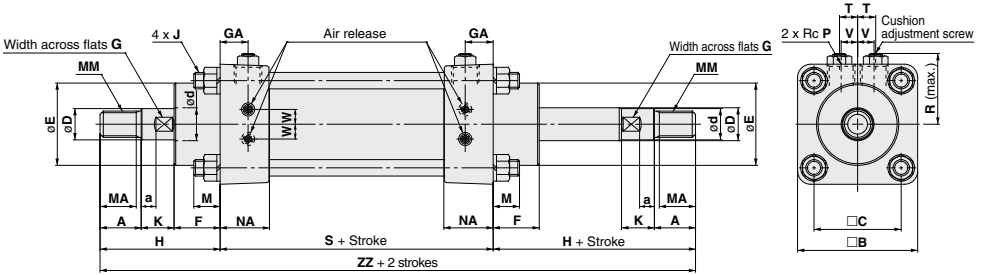

Bore size (mm)	A	a	□B	□C	D	d	E	F	G	GA	J	K	M	MA	MM	NA	P	R	S	T	V	W	H	ZZ
40	23	10	60	44	17 <sup>0</sup> <sub>-0.018</sub>	18	45 <sup>0</sup> <sub>-0.062</sub>	25	14	17.5	M8 x 1.25	18	13	20	M14 x 1.5	30	1/4	37	114	11	7.5	8	66	246
50	25	9	73	53	19 <sup>0</sup> <sub>-0.021</sub>	20	50 <sup>0</sup> <sub>-0.062</sub>	28	17	17	M10 x 1.5	20	16	22	M16 x 1.5	30	3/8	43	116	11	10	9	73	262
63	28	8	80	60	21 <sup>0</sup> <sub>-0.021</sub>	22.4	55 <sup>0</sup> <sub>-0.074</sub>	30	17	17	M10 x 1.5	22	16	25	M18 x 1.5	30	3/8	47	120	11	12	10	80	280
80	32	8	100	75	26 <sup>0</sup> <sub>-0.021</sub>	28	65 <sup>0</sup> <sub>-0.074</sub>	32	22	20	M12 x 1.75	26	19	29	M22 x 1.5	35	1/2	57	132	11	16	13	90	312
100	38	6.5	118	90	34 <sup>0</sup> <sub>-0.025</sub>	35.5	80 <sup>0</sup> <sub>-0.074</sub>	35	27	19	M12 x 1.75	27	21	34	M27 x 2	35	1/2	66	140	12	20	16	100	340
125	38	6.5	140	112	34 <sup>0</sup> <sub>-0.025</sub>	35.5	80 <sup>0</sup> <sub>-0.074</sub>	35	27	19	M14 x 2	27	24	34	M27 x 2	35	1/2	77	140	12	20	16	100	340
160	42	9	174	140	43 <sup>0</sup> <sub>-0.025</sub>	45	100 <sup>0</sup> <sub>-0.087</sub>	38	36	22	M16 x 2	28	27	38	M33 x 2	40	3/4	94	159	12	24	20	108	375

Foot type: CHAWL

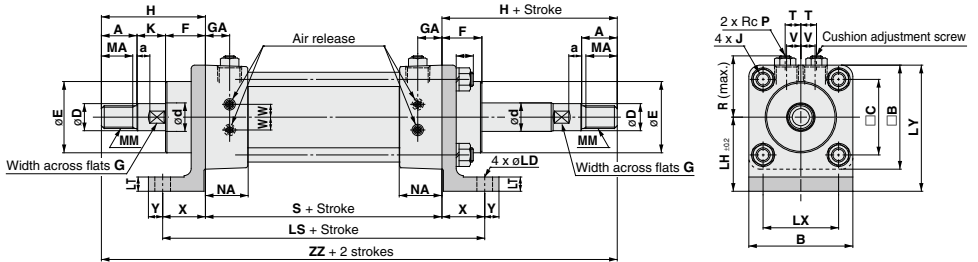

- CHQ
- CHK
- CHN
- CHM
- CHS
- CH2
- CHA
- Related Products
- D-

Bore size (mm)	(mm)																							
	A	a	B	□B	□C	D	d	E	F	G	GA	H	J	K	LD	LH	LS	LT	LX	LY	M	MA	MM	NA
40	23	10	60	60	44	17 <sup>0</sup> <sub>-0.018</sub>	18	45 <sup>0</sup> <sub>-0.062</sub>	25	14	17.5	66	M8 x 1.25	18	9	47	168	8	44	77	10	20	M14 x 1.5	30
50	25	9	73	73	53	19 <sup>0</sup> <sub>-0.021</sub>	20	50 <sup>0</sup> <sub>-0.062</sub>	28	17	17	73	M10 x 1.5	20	11	52	176	10	53	88.5	12	22	M16 x 1.5	30
63	28	8	80	80	60	21 <sup>0</sup> <sub>-0.021</sub>	22.4	55 <sup>0</sup> <sub>-0.074</sub>	30	17	17	80	M10 x 1.5	22	11	55	194	10	60	95	12	25	M18 x 1.5	30
80	32	8	100	100	75	26 <sup>0</sup> <sub>-0.021</sub>	28	65 <sup>0</sup> <sub>-0.074</sub>	32	22	20	90	M12 x 1.75	26	13	65	212	12	75	115	14	29	M22 x 1.5	35
100	38	6.5	118	118	90	34 <sup>0</sup> <sub>-0.025</sub>	35.5	80 <sup>0</sup> <sub>-0.074</sub>	35	27	19	100	M12 x 1.75	27	13	80	234	14	90	139	14	34	M27 x 2	35
125	38	6.5	140	140	112	34 <sup>0</sup> <sub>-0.025</sub>	35.5	80 <sup>0</sup> <sub>-0.074</sub>	35	27	19	100	M14 x 2	27	15	100	250	16	112	170	16	34	M27 x 2	35
160	42	9	174	174	140	43 <sup>0</sup> <sub>-0.025</sub>	45	100 <sup>0</sup> <sub>-0.087</sub>	38	36	22	108	M16 x 2	28	17	110	279	18	140	197	18	38	M33 x 2	40

Bore size (mm)	(mm)									
	P	R	S	T	V	W	X	Y	ZZ	
40	1/4	37	114	11	7.5	8	27	8	246	
50	3/8	43	116	11	10	9	30	10	262	
63	3/8	47	120	11	12	10	37	10	280	
80	1/2	57	132	11	16	13	40	13	312	
100	1/2	66	140	12	20	16	47	13	340	
125	1/2	77	140	12	20	16	55	15	340	
160	3/4	94	159	12	24	20	60	20	375	

# CHAW Series

## Dimensions

### Rod flange type: CHAWF

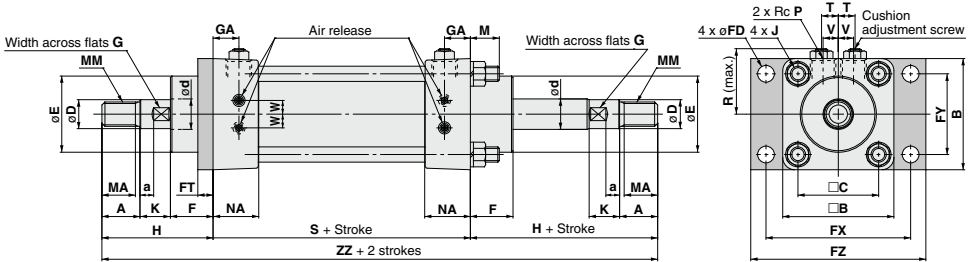

Bore size (mm)	A	a	B	□B	□C	D	d	E	F	FD	FT	FX	FY	FZ	G	GA	H	J	K	M	MA	MM	NA	P
40	23	10	60	60	44	17 <sup>0</sup> <sub>-0.018</sub>	18	45 <sup>0</sup> <sub>-0.062</sub>	25	9	10	77	44	95	14	17.5	66	M8 x 1.25	18	16	20	M14 x 1.5	30	1/4
50	25	9	73	73	53	19 <sup>0</sup> <sub>-0.021</sub>	20	50 <sup>0</sup> <sub>-0.062</sub>	28	11	10	95	53	115	17	17	73	M10 x 1.5	20	22	22	M16 x 1.5	30	3/8
63	28	8	80	80	60	21 <sup>0</sup> <sub>-0.021</sub>	22.4	55 <sup>0</sup> <sub>-0.074</sub>	30	11	12	102	60	122	17	17	80	M10 x 1.5	22	20	25	M18 x 1.5	30	3/8
80	32	8	100	100	75	26 <sup>0</sup> <sub>-0.021</sub>	28	65 <sup>0</sup> <sub>-0.074</sub>	32	13	12	130	75	155	22	20	90	M12 x 1.75	26	26	29	M22 x 1.5	35	1/2
100	38	6.5	118	118	90	34 <sup>0</sup> <sub>-0.025</sub>	35.5	80 <sup>0</sup> <sub>-0.074</sub>	35	13	16	145	90	172	27	19	100	M12 x 1.75	27	26	34	M27 x 2	35	1/2
125	38	6.5	140	140	112	34 <sup>0</sup> <sub>-0.025</sub>	35.5	80 <sup>0</sup> <sub>-0.074</sub>	35	15	18	170	112	200	27	19	100	M14 x 2	27	30	34	M27 x 2	35	1/2
160	42	9	174	174	140	43 <sup>0</sup> <sub>-0.025</sub>	45	100 <sup>0</sup> <sub>-0.087</sub>	38	17	20	205	140	240	36	22	108	M16 x 2	28	34	38	M33 x 2	40	3/4

(mm)

Bore size (mm)	R	S	T	V	W	ZZ
40	37	114	11	7.5	8	246
50	43	116	11	10	9	262
63	47	120	11	12	10	280
80	57	132	11	16	13	312
100	66	140	12	20	16	340
125	77	140	12	20	16	340
160	94	159	12	24	20	375

Center trunnion type: **CHAWT**

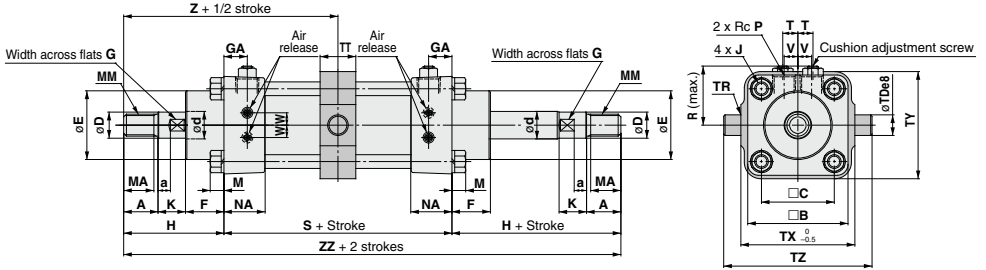

- CHQ
- CHK
- CHN
- CHM
- CHS
- CH2
- CHA
- Related Products
- D-

Bore size (mm)	A	a	$\square B$	$\square C$	D	d	E	F	G	GA	H	J	K	M	MA	MM	NA	P	R	S	T	TDe8	TR
40	23	10	60	44	$17_{-0.018}^0$	18	$45_{-0.062}^0$	25	14	17.5	66	M8 x 1.25	18	10	20	M14 x 1.5	30	1/4	37	114	11	$15_{-0.032}^{-0.059}$	R0.5
50	25	9	73	53	$19_{-0.021}^0$	20	$50_{-0.062}^0$	28	17	17	73	M10 x 1.5	20	10	22	M16 x 1.5	30	3/8	43	116	11	$15_{-0.032}^{-0.059}$	R0.5
63	28	8	80	60	$21_{-0.021}^0$	22.4	$55_{-0.074}^0$	30	17	17	80	M10 x 1.5	22	10	25	M18 x 1.5	30	3/8	47	120	11	$15_{-0.032}^{-0.059}$	R0.5
80	32	8	100	75	$26_{-0.021}^0$	28	$65_{-0.074}^0$	32	22	20	90	M12 x 1.75	26	13	29	M22 x 1.5	35	1/2	57	132	11	$25_{-0.040}^{-0.073}$	R2.5
100	38	6.5	118	90	$34_{-0.025}^0$	35.5	$80_{-0.074}^0$	35	27	19	100	M12 x 1.75	27	13	34	M27 x 2	35	1/2	66	140	12	$32_{-0.050}^{-0.089}$	R2.5
125	38	6.5	140	112	$34_{-0.025}^0$	35.5	$80_{-0.074}^0$	35	27	19	100	M14 x 2	27	15	34	M27 x 2	35	1/2	77	140	12	$32_{-0.050}^{-0.089}$	R2.5
160	42	9	174	140	$43_{-0.025}^0$	45	$100_{-0.087}^0$	38	36	22	108	M16 x 2	28	17	38	M33 x 2	40	3/4	94	159	12	$36_{-0.050}^{-0.089}$	R2.5

(mm)											
Bore size (mm)	TT	TX	TY	TZ	V	W	Z	ZZ			
40	24	70	65	95	7.5	8	123	246			
50	26	83	78	108	10	9	131	262			
63	26	90	86	115	12	10	140	280			
80	36	112	106	162	16	13	156	312			
100	42	140	130	204	20	16	170	340			
125	42	170	162	234	20	16	170	340			
160	52	212	200	284	24	20	187.5	375			

# CHAW Series

## Dimensions

### Rod trunnion type: CHAWU

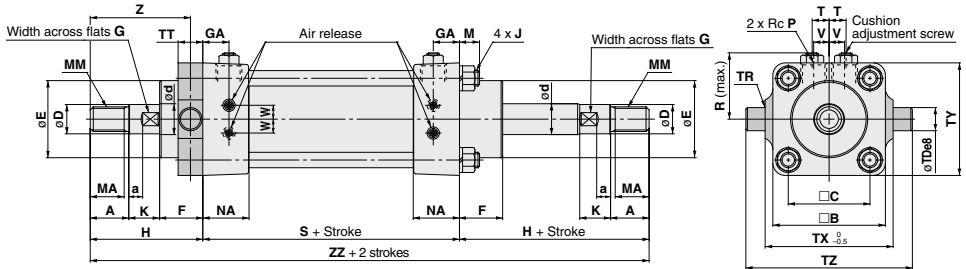

Bore size (mm)	A	a	B	C	D	d	E	F	G	GA	H	J	K	M	MA	MM	NA	P	R	S	T	TDe8	TR
40	23	10	60	44	17 $^{0}_{-0.018}$	18	45 $^{0}_{-0.062}$	25	14	17.5	66	M8 x 1.25	18	10	20	M14 x 1.5	30	1/4	37	114	11	15 $^{-0.032}_{-0.059}$	R0.5
50	25	9	73	53	19 $^{0}_{-0.021}$	20	50 $^{0}_{-0.062}$	28	17	17	73	M10 x 1.5	20	13	22	M16 x 1.5	30	3/8	43	116	11	15 $^{-0.032}_{-0.059}$	R0.5
63	28	8	80	60	21 $^{0}_{-0.021}$	22.4	55 $^{0}_{-0.074}$	30	17	17	80	M10 x 1.5	22	15	25	M18 x 1.5	30	3/8	47	120	11	15 $^{-0.032}_{-0.059}$	R0.5
80	32	8	100	75	26 $^{0}_{-0.021}$	28	65 $^{0}_{-0.074}$	32	22	20	90	M12 x 1.75	26	13	29	M22 x 1.5	35	1/2	57	132	11	25 $^{-0.040}_{-0.073}$	R2.5
100	38	6.5	118	90	34 $^{0}_{-0.025}$	35.5	80 $^{0}_{-0.074}$	35	27	19	100	M12 x 1.75	27	13	34	M27 x 2	35	1/2	66	140	12	32 $^{-0.050}_{-0.089}$	R2.5
125	38	6.5	140	112	34 $^{0}_{-0.025}$	35.5	80 $^{0}_{-0.074}$	35	27	19	100	M14 x 2	27	15	34	M27 x 2	35	1/2	77	140	12	32 $^{-0.050}_{-0.089}$	R2.5
160	42	9	174	140	43 $^{0}_{-0.025}$	45	100 $^{0}_{-0.087}$	38	36	22	108	M16 x 2	28	17	38	M33 x 2	40	3/4	94	159	12	36 $^{-0.050}_{-0.089}$	R2.5

(mm)

Bore size (mm)	TT	TX	TY	TZ	V	W	Z	ZZ
40	16	70	60	95	7.5	8	58	246
50	16	83	73	108	10	9	65	262
63	16	90	80	115	12	10	72	280
80	30	112	100	162	16	13	75	312
100	34	140	118	204	20	16	83	340
125	34	170	140	234	20	16	83	340
160	38	212	174	284	24	20	89	375