

Datasheet

Three- and four-wire convergent mode scanner blocks for MULTI-BEAM Modular Photoelectric Sensors

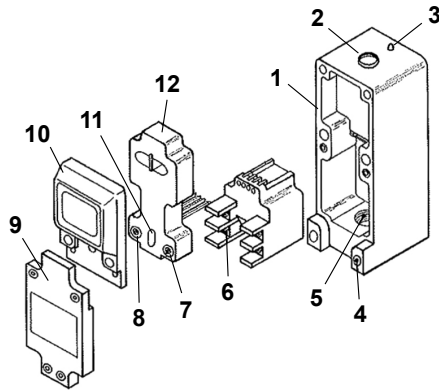

1. Scanner block housing
2. Access to sensitivity adjustment (located under the lower cover)
3. Status/alignment indicator LED
4. Mounting hole
5. Conduit entrance
6. Wiring terminals on the power block
7. Logic timing adjustment
8. Logic timing adjustment
9. Lower cover, supplied with the scanner block
10. Upper cover (lens), supplied with the scanner block
11. Light/dark operate select
12. Logic module

A scanner block consists of a scanner block housing, an upper cover assembly, and a lower cover. Other modular components (logic module and power block module) are purchased separately.



WARNING:

- **Do not use this device for personnel protection**
- Using this device for personnel protection could result in serious injury or death.
- This device does not include the self-checking redundant circuitry necessary to allow its use in personnel safety applications. A device failure or malfunction can cause either an energized (on) or de-energized (off) output condition.

Models

Convergent mode MULTI-BEAM sensors combine the emitter and receiver into one unit. Optics produce a sensing "spot" at a fixed distance (focus point) in front of the lens.

Convergent mode sensing is an ideal choice for position control of transparent products and for detecting products that are only a fraction of an inch away from another reflective surface. Convergent sensing is also a good second choice (after opposed mode sensing) for precise position control of opaque materials. All models have Banner's exclusive AID™ alignment system.

Models	Focus	Response Time	Beam	Application Notes
SBCV1	38 mm (1.5 in)	1 ms on/off	650 nm visible red	1.5 mm (0.06 in) dia, visible red spot, for precise positioning, edge-guiding, and small parts detection. Some products larger than 1 inch tall may be sensed against an immediate background, like parts on a conveyor. Excellent for high-contrast, registration-sensing applications (except red on white). Use with LM6-1 logic module for speed detection sensing of gear teeth, pulley hubs, or chain links.
SBCVG1			560 nm visible green	3 mm (0.12 in) dia, visible green spot. Use to detect color differences (for example, color registration marks), including red-on-white combinations.
SBC1	38 mm (1.5 in)	1 ms on/off	940 nm infrared	Infrared LED light source provides higher gain for reliable sensing of products of low reflectivity, while controlling sensing depth of field. Does not offer the same precision possible with visible light models. Good for sensing clear materials within the sensor's depth of field, and for reliably counting the flow of radiused products that are kept at a fixed distance from the sensor (for example, bottles against a conveyor guide rail).
SBC1-4	100 mm (4 in)			
SBC1-6	150 mm (6 in)			
SBCX1	38 mm (1.5 in)	10 ms on/off	880 nm infrared	These models offer the greatest optical gain available in any reflective mode sensor. They can reliably detect most non-reflective black materials in applications where opposed mode sensing is not possible (for example, inked web break monitoring). The high power of these models gives them a wide depth of field and a large sensing spot. As a result, they cannot easily ignore objects in the background or foreground, and cannot be used for precise position control (use model SBCV1).
SBCX1-4	100 mm (4 in)			
SBCX1-6	150 mm (6 in)			



MULTI-BEAM Scanner Block Modifications

The following are common modifications to MULTI-BEAM 3- and 4-wire scanner blocks. They are not stocked, but are available on a quote basis.

Zero Hysteresis Modification "MZ". Amplifier hysteresis may be removed from 3- and 4-wire scanner blocks when attempting to sense very small signal changes (contrasts less than 3). This modification is designated by adding suffix "MZ" (modified zero hysteresis). Verify all variables affecting the sensor's optical response remain constant before ordering the zero hysteresis modification.

High Speed Modification "MHS". Scanner blocks with 1 millisecond response may be modified for 300 microsecond (0.3 ms) response. This modification is designated by adding suffix "MHS" to the scanner block model number (for example, **SBCV1MHS**). The MHS modification reduces the available excess gain by about 50% and also decreases the sensor's immunity to some forms of electrical noise.

Overview

A Banner MULTI-BEAM sensor is a compact modular self-contained photoelectric switch consisting of three components: a scanner block, a power block, and a logic module.

The **scanner block**, described in this datasheet, comprises the housing for the sensor and contains a complete modulated photoelectric amplifier, the emitter or receiver optoelements and lenses, and space for the other modules.

The **power block** module provides the interface between the scanner block and the external circuit. It contains a power supply for the MULTI-BEAM plus a switching device to interface the sensor to the circuit to be controlled. Three- and four-wire dc power block modules operate from dc voltages and are discussed in datasheet 03499. Three- and four-wire ac power blocks operate from ac voltages and are covered in datasheet 03501.

The **logic module** (datasheet 03304) interconnects the power block and receiver scanner block both electrically and mechanically. It provides the desired timing logic function (if any) plus the ability to program the output for either light- or dark-operate.

Power block and logic modules are purchased separately. This modular design, with field-replaceable power block and logic modules, permits a variety of sensor configurations, resulting in exactly the right sensor for any opposed mode photoelectric application.

MULTI-BEAM 3- and 4-wire convergent mode scanner blocks include eight different standard models. The high power models (those with 10 millisecond response time) offer the greatest optical sensing power of any industrial convergent mode sensor.

The circuitry of all MULTI-BEAM components is encapsulated within rugged, corrosion-resistant VALOX® housings that meet or exceed NEMA 1, 3, 12, and 13 ratings. MULTI-BEAM 3- and 4-wire receiver scanner blocks include Banner's exclusive, patented ¹, Alignment Indicating Device (AID™) system, which lights a top-mounted LED when the sensors sees its modulated light source and pulses at a rate proportional to the strength of the received light signal.

All MULTI-BEAM scanner blocks are solid-state for unlimited life.

Figure 1. Functional Schematic

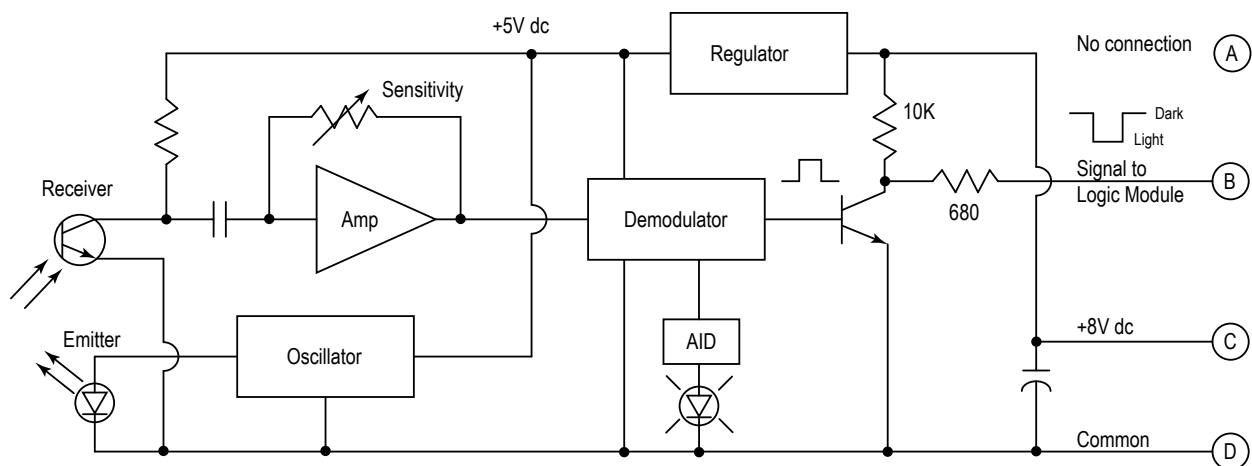

¹ U.S. patent 4356393

Banner's Alignment Indicating Device (AID™) System

Banner's Alignment Indicating Device (AID) system² is an exclusive built-in feature that permits optimum alignment and continuous monitoring of the photoelectric system. The red receiver LED indicator is on when the receiver sees the modulated light from the emitter and is off when the beam is broken. In addition, a low frequency pulse rate is superimposed on the LED indicator. When alignment is marginal, the pulse rate will be about once per second (indicating an excess gain of 1). As alignment is improved, the pulse rate increases, indicating increased excess gain. Optimum sensor alignment is indicated by the fastest pulse rate.

The AID feature also tells you when maintenance is necessary. Any pulse rate less than two per second indicates marginal performance; the unit, however, is still functioning properly. When the pulse rate slows to less than two per second, clean the lenses and check the alignment.

Installation and Alignment

The greatest amount of light energy is returned to the receiver of a convergent sensor when the reflecting surface is located at the sensor's focus point. A convergent sensor will sense an object for some distance in front of and behind the focus point. This zone of response is the convergent sensor's depth of field.

The depth of the sensing field is determined both by the sensor's optical gain and by the reflectivity characteristics of the object to be sensed. As a reference, the depth of field for a matte white object is read along the horizontal axis of the sensor's excess gain curve or beam pattern. A smaller depth of field will result with an object of low reflectivity. Conversely, a shiny surface, if viewed straight-on, will be detected within a large depth of field.

Figure 2. "Skew" angle included in mounting scheme to ignore shiny background surface.

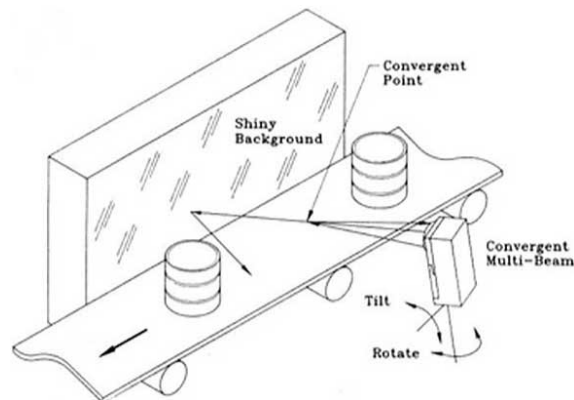

Problems with convergent sensing are often the result of false light return from a highly reflective background surface. This type of problem is easily corrected by tilting the MULTI-BEAM more than 10 degrees in any direction from the perpendicular to the shiny background surface. With the sensor tilted, the shiny background surface directs the reflected sensing light away from the convergent sensor (specular reflection). There usually is enough light energy for sensing purposes right at the convergent point to overcome any angular misalignment of the sensor to the object that is to be sensed.

In some situations where the background surface is highly reflective and where the object to be detected has very low reflectivity, the convergent beam sensor may be directed squarely at the background surface. The object is sensed when it passes inside the convergent point, and blocks the light from reaching the background.

Banner offers a variety of 2- and 3-axis mounting brackets for use with MULTI-BEAM sensors.

Aligning the Sensor for Presence/Absence Applications

Use the Alignment Indicating Device LED on the top of the sensor during alignment.

1. Loosely mount the MULTI-BEAM so that the distance from the front surface of the lens to the object to be detected is equal to the sensor's focus distance.
2. Apply power to the MULTI-BEAM power block (terminals #1 and #2; observe polarity on DC models).
3. Adjust the position of the MULTI-BEAM relative to the object for the fastest pulse rate of the alignment indicator. If the LED appears to be on, it is pulsing at a rate too fast to be seen. Slow the pulsing to a "countable" rate by reducing the sensitivity (counterclockwise rotation of the adjustment). Being able to count the change in pulse rate when the sensor's position is changed will allow more accurate alignment.
4. Turn the sensitivity control fully clockwise. (This is a 15-turn potentiometer, clutched at both ends.)
5. Remove the object. If the alignment indicator LED goes off, secure the MULTI-BEAM in that position.
6. Check the sensor operation by alternately placing the object in position and then removing it. The LED should turn on when the object is present and turn off when the object is removed.

² U.S. Patent 4356393

- If the alignment indicator stays on when the object is removed, the MULTI-BEAM is receiving false light returned from a background surface. Reduce the sensitivity (counterclockwise rotation of the adjustment) until the alignment indicator LED goes off, plus two more full turns. Place the object in position and check that the alignment indicator LED comes on. Repeat the previous step.
- If the LED does not come on when the object is placed in position, the sensor is receiving as much or more light from the background as from the object. Consider including a skew angle in the sensor mounting or converging on the background.

The alignment indicator LED may pulse when the object is present. Sensing reliability increases with increasing pulse rates. The LED on is the best situation, but this may not always be possible if the object has low reflectivity.

Aligning the Sensor for Color Registration Applications

For color registration applications, use the visible LED SBCVG1 or SBCV1 model.

Figure 3. Color sensing with SBCVG1 or SBCV1 -- Include a "skew" angle to mounting when the material is shiny.

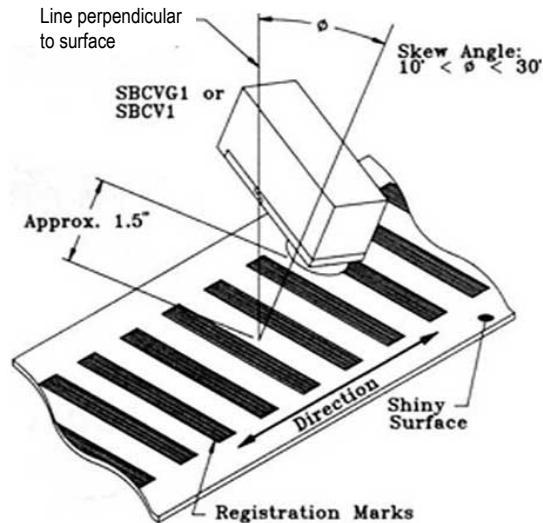

MULTI-BEAM scanner block model SBCVG1 (visible green emitter) is used for most applications that require color differentiation. Model SBCV1 (visible red emitter) performs well with most bold color differences, except those involving red on white and similar contrasts (for example, orange on yellow).

Most applications like registration control, which involve differentiating between two colors, operate with low optical contrast -- only a small difference in light level at the sensor's receiver between the light and dark conditions. As a result, secure mounting and proper alignment of the MULTI-BEAM are particularly important.

It is also necessary to maintain the mechanical stability of the surface being sensed (stabilize web flutter). To consistently sense color differences, the MULTI-BEAM's convergent optics require a constant distance between the sensor lens and the sensed surface.

1. Loosely mount the MULTI-BEAM so the distance from the lens' front surface to the scanned surface is equal to the sensor's focus point (1.5 inches for models SBCVG1 and SBCV1).
2. Apply power to the power block (terminals #1 and #2 - observe polarity on DC models).
3. Position the material so that the visible image (spot) of the emitted light is reflecting from the lighter of the two colors.
4. Adjust the sensor position to obtain the fastest pulse rate of the Alignment Indicating Device LED, then lock the sensor into that position by tightening the mounting hardware.

If the material to be sensed is shiny, the sensor may receive too much light reflected from the darker color if the sensor is mounted directly perpendicular to the material's surface. Include a 10 to 30 degree skew angle, when mounting the MULTI-BEAM, to compensate for the mirror-like properties of a shiny surface.

5. Present the darker of the two colors to the visible image.
 - If the alignment indicator turns off when the visible image is on the dark color, increase the sensitivity (turn the adjustment clockwise) until the alignment indicator just turns on. Reduce the sensitivity control from that point until the alignment indicator just turns off, plus two more full turns.
 - If the alignment indicator stays on when the visible image is on the dark color, decrease the sensitivity (turn the adjustment counterclockwise) until the alignment indicator just turns off, plus two more full turns.
 - If the alignment indicator does not turn on even at maximum gain (15-turn control fully clockwise) when the visible image (spot) is on the dark color, set the control to two full turns down from maximum. If the sensitivity control setting ends up near minimum, the dark color is returning too much light energy to the sensor. In this case, readjust the sensor mounting to increase the skew angle. This allows the sensitivity to be set closer to the middle of its range, where adjustment is more forgiving.

Final Adjustment and Test

When alignment is completed and mounting hardware secured, finish wiring the scanner block by connecting the load to the output circuit of the power block (terminals 3 and/or 4). Refer to the hookup diagram for the power block in use. Check the operation of the load by placing an object in front of the sensing component (lens or sensing tip) and removing it. The load and the alignment indicator LED should follow the action. Adjust the logic module timing (if any), as required.

Logic modules (except models LM1, LM2, and LM10) include a light/dark programming jumper. Removing the jumper will invert the output state of the power block from normally open to normally closed, or vice versa.



CAUTION: DO NOT remove the programming jumper while power is applied to the MULTI-BEAM.

If you have any difficulties with the installation of your sensing system, contact your local Banner Engineering Corp representative or contact our applications engineers during normal business hours.

Troubleshooting

Symptom	Probable Cause	Solution
Alignment indicator never comes on and the output never switches the load.	Sensitivity is too low.	Turn the sensitivity control clockwise to increase gain.
	Object to be sensed is outside the MULTI-BEAM's field of view.	Follow alignment procedure.
	Loose connection.	Check power supply at power block terminals #1 and #2.
	Failure of a sensor component.	Test MULTI-BEAM using Banner model LMT. Replace failed module.
Alignment Indicator never comes on but the load is switched correctly.	Broken alignment indicator LED (sensor will continue to operate).	Replace scanner block (if alignment indicator is required).
Alignment indicator is always on and the output never switches.	False light returned by background object.	Turn sensitivity control counterclockwise to decrease the gain. Angle the sensor if the background is shiny. Use a model with less gain and/or a shorter focus point.
	Optical crosstalk from broken lens.	Turn the sensitivity control counterclockwise to decrease the gain. Replace the upper cover assembly.
	Failure of sensor component.	Test the MULTI-BEAM using Banner model LMT. Replace the failed module.
Alignment indicator follows the sensing action, normally, but the output is energized all of the time.	Output of power block failed (shorted).	Replace the power block module. Check the load demand against the power block switch rating.
Alignment indicator follows the sensing action, normally, but the output never energizes.	Failure of logic module or power block.	Test MULTI-BEAM using Banner model LMT. Replace the failed module.
	There is a loose connection.	Check wires to load.
Sensitivity cannot be set to sense the difference between the light and dark conditions. The sensitivity is either too high or too low.	Low optical contrast (less than 2:1).	Re-position the MULTI-BEAM and follow the alignment procedure. Increase the difference in reflectivity between the light and dark conditions (drill hole through background). Evaluate alternative sensing methods.

Specifications

Supply Voltage

Input power and output connections are made via 3-or 4-wire power blocks.
See datasheet 03499 (DC Power Blocks) or 03501 (AC Power Blocks)

Construction

Reinforced VALOX® housing; components totally encapsulated
Stainless steel hardware
Meets NEMA standards 1, 3, 12, and 13

Operating Temperature

-40 °C to +70 °C (-40 °F to +158 °F)

Response Time

1 millisecond on and off
High-gain models (X model suffix) 10 milliseconds on and off
Independent of signal strength

Repeatability of Response

0.3 milliseconds (1.5 milliseconds for "X" models)
Independent of signal strength

Sensitivity Adjustment

Easily-accessible, located on top of receiver scanner block beneath o-ring gasketed nylon screw cover; 15-turn clutched control, rotate clockwise to increase sensitivity

Alignment Indicator

Red LED on top of receiver scanner block
Banner's exclusive, patented Alignment Indicating Device (AID™) circuit lights the LED when the receiver sensor detects its own modulated light source and pulses the LED at a rate proportional to the received light level.

Dimensions

All measurements are listed in millimeters [inches], unless noted otherwise.

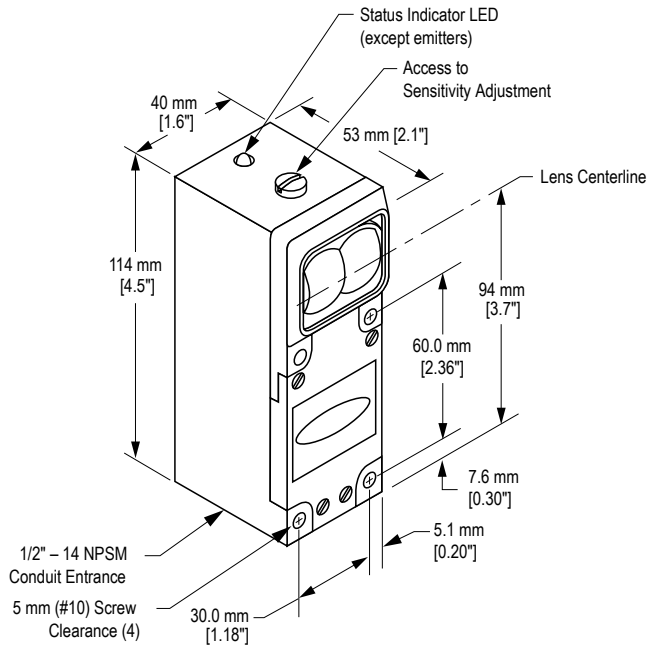

Performance Curves

Distances are measured using a 90% white test card.

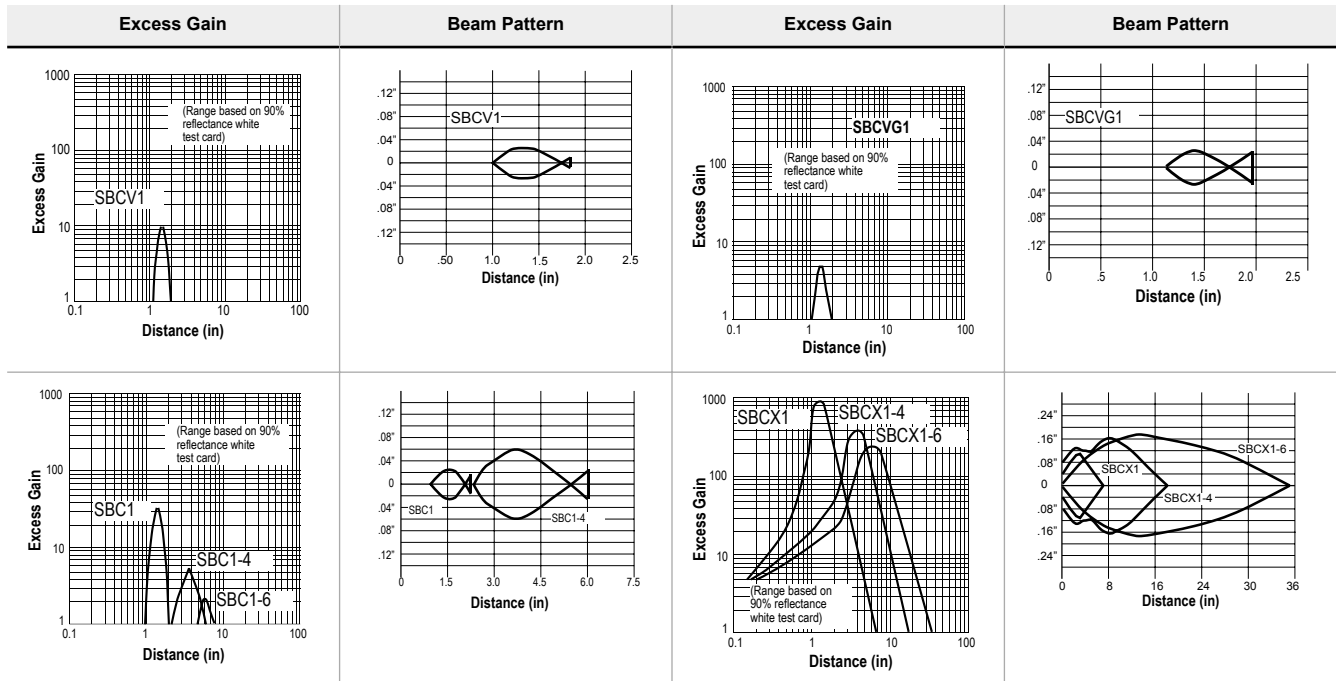

Banner Engineering Corp. Limited Warranty

Banner Engineering Corp. warrants its products to be free from defects in material and workmanship for one year following the date of shipment. Banner Engineering Corp. will repair or replace, free of charge, any product of its manufacture which, at the time it is returned to the factory, is found to have been defective during the warranty period. This warranty does not cover damage or liability for misuse, abuse, or the improper application or installation of the Banner product.

THIS LIMITED WARRANTY IS EXCLUSIVE AND IN LIEU OF ALL OTHER WARRANTIES WHETHER EXPRESS OR IMPLIED (INCLUDING, WITHOUT LIMITATION, ANY WARRANTY OF MERCHANTABILITY OR FITNESS FOR A PARTICULAR PURPOSE), AND WHETHER ARISING UNDER COURSE OF PERFORMANCE, COURSE OF DEALING OR TRADE USAGE.

This Warranty is exclusive and limited to repair or, at the discretion of Banner Engineering Corp., replacement. **IN NO EVENT SHALL BANNER ENGINEERING CORP. BE LIABLE TO BUYER OR ANY OTHER PERSON OR ENTITY FOR ANY EXTRA COSTS, EXPENSES, LOSSES, LOSS OF PROFITS, OR ANY INCIDENTAL, CONSEQUENTIAL OR SPECIAL DAMAGES RESULTING FROM ANY PRODUCT DEFECT OR FROM THE USE OR INABILITY TO USE THE PRODUCT, WHETHER ARISING IN CONTRACT OR WARRANTY, STATUTE, TORT, STRICT LIABILITY, NEGLIGENCE, OR OTHERWISE.**

Banner Engineering Corp. reserves the right to change, modify or improve the design of the product without assuming any obligations or liabilities relating to any product previously manufactured by Banner Engineering Corp. Any misuse, abuse, or improper application or installation of this product or use of the product for personal protection applications when the product is identified as not intended for such purposes will void the product warranty. Any modifications to this product without prior express approval by Banner Engineering Corp will void the product warranties. All specifications published in this document are subject to change; Banner reserves the right to modify product specifications or update documentation at any time. Specifications and product information in English supersede that which is provided in any other language. For the most recent version of any documentation, refer to:

www.bannerengineering.com.

For patent information, see www.bannerengineering.com/patents.



more sensors, more solutions