

SWITCHING SOLUTIONS FOR IRRIGATION APPLICATIONS



Honeywell

SWITCHING SOLUTIONS IN ACTION

Two MICRO SWITCH BZ switches perform the start and stop functions within the tower/control boxes.

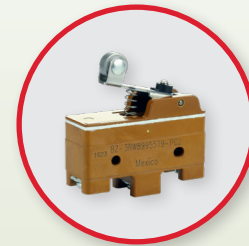

MICRO SWITCH e-stop switches may be located on the panel box to provide system shut off.



MICRO SWITCH HDLS heavy-duty limit switch provides safety and crash detection, along with position stop.

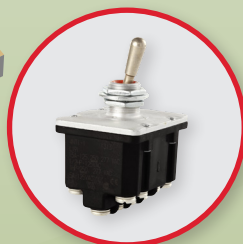

MICRO SWITCH toggle switches are designed to turn lights off and on.

BZ switches also provide directional guidance promoting alignment of each span within a given system

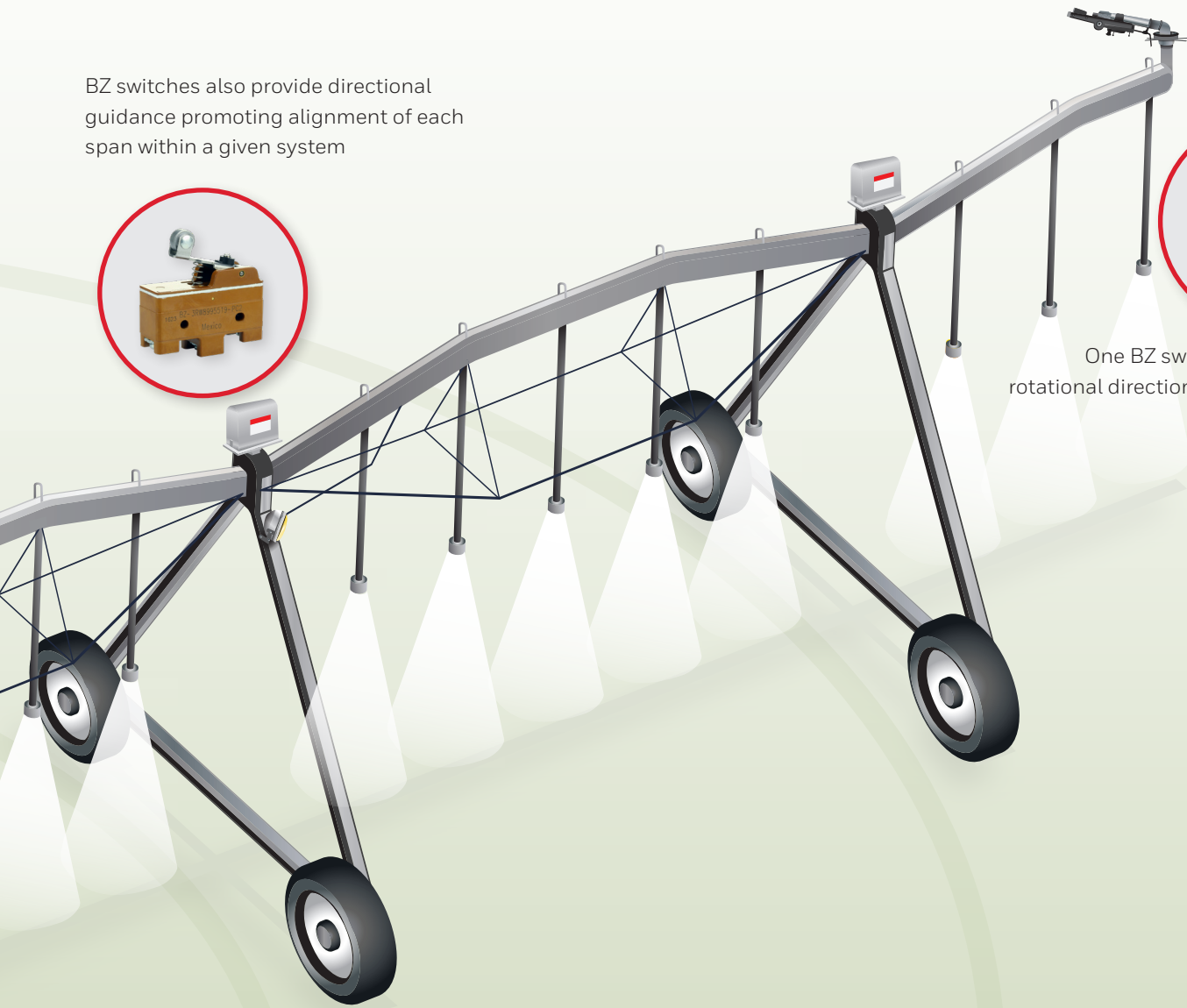
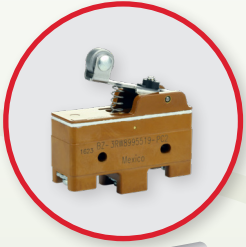

One BZ switch controls the rotational direction of the end gun.

ACCURATE AND PRECISE CONTROL

Since their introduction within the agriculture market segment, center-pivot irrigation systems have relied on Honeywell's MICRO SWITCH technology to provide accurate and consistent performance year-after-year in some of the most challenging environments.

As these irrigation designs have evolved, so have the MICRO SWITCH products. Over the years, Honeywell has collaborated with manufacturers to expand switch offerings to meet the exact needs of these complex and critical structures. What hasn't changed is Honeywell's commitment to manufacturing rugged, reliable, and accurate switches that exceed performance standards in wet, dusty, and challenging environments and applications.

To understand the important role Honeywell MICRO SWITCH products perform in irrigation systems, it's key to have a basic understanding of the center pivot application and some of the associated terminology.

CENTER PIVOT IRRIGATION APPLICATION AND TERMINOLOGY

The irrigation system's pivot point and the componentry that ensures the functionality is permanently anchored in a field location. In a typical set up, there are four pivot legs affixed to a concrete pad that provide stability and support. Within the four legs, the riser pipe flows upwards as it carries the water supply to the pivot swivel at the apex of the four pivot legs. The pivot swivel is an elbow-shaped fitting that provides the connection between the riser pipe and the first irrigation section. At each section/span connection, a tower/control box commands the pivot. There may be as many as 7-8 spans within a typical center-pivot set-up.

The J-Pipe and collector ring provide a continuous supply of electricity to the system as control circuit wires travel through them from the power supply. A control panel is incorporated that passes commands to the center pivot. Based on inputs from throughout the system, the panel controls the starting, stopping, speed, directional changes, and more.

HONEYWELL SWITCHES ACCURATELY CONTROLLING THE SYSTEM

Within the tower/control box, [MICRO SWITCH BZ basic switches](#) are the key components to the overall guidance of the system (see Figure 1). Two switches perform the start and stop functions within the tower/control boxes located on each span. The switches' function on the center pivot towers maintains alignment across the entire system during motion. As explained, a control box is incorporated into each tower section – for example, in a typical 7-section/pivot system, there would be 14 BZ switches incorporated into a typical center pivot irrigation application.

One BZ switch operates as the run switch that starts and stops the pivot (it has a much higher duty cycle than the secondary switch). The subsequent BZ is used as the overtravel (stop) switch that stops the driver motor when the alignment angle is beyond 10°, which has a lower duty cycle. At the heart of the switch design is the special alloy snap spring that fights corrosive elements of the chemicals and fertilizer routinely used in agriculture.

Figure 1. MICRO SWITCH BZ Switches in the Tower/Control Box

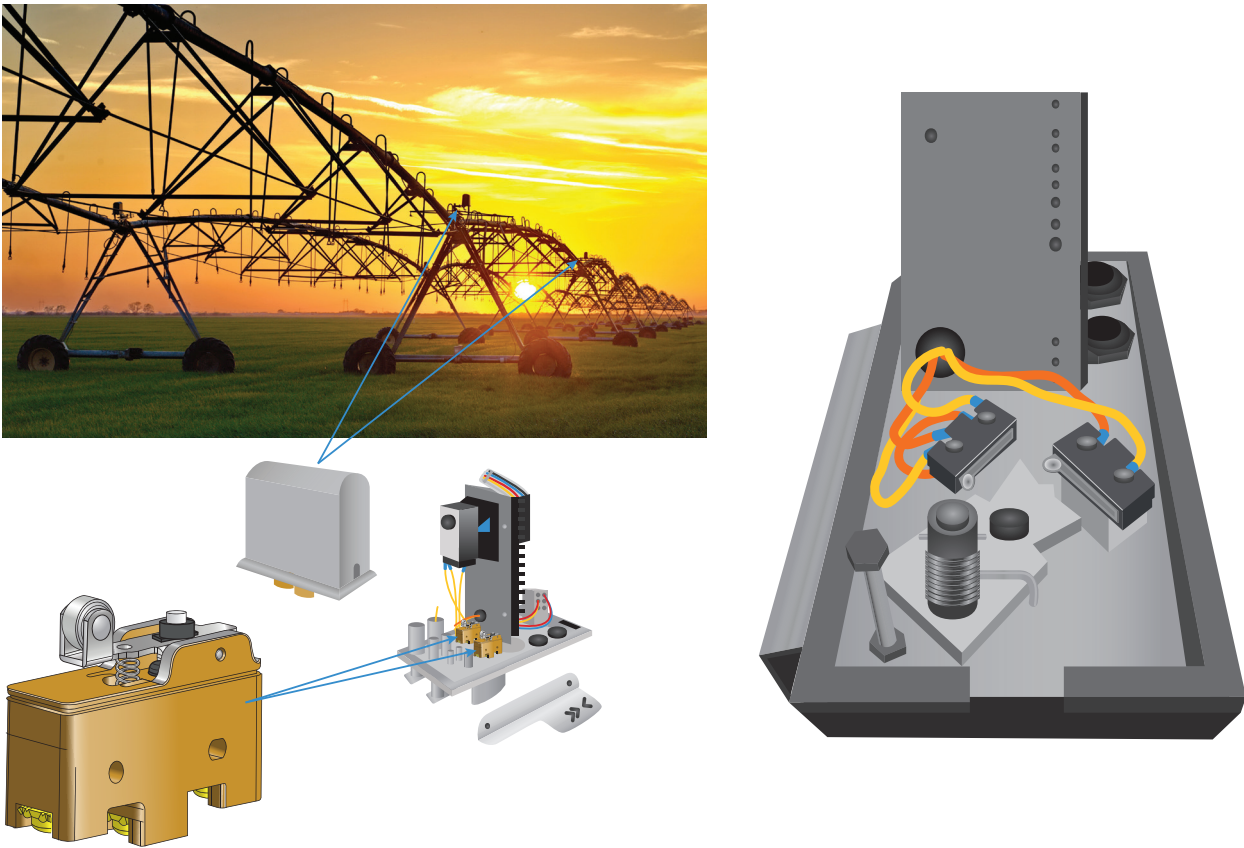

BZ Series switches deliver dependable performance, with some switches certified up to 20 million mechanical cycles. The internal flat-spring design is ideal for applications requiring precision switch characteristics and long life. These precision switches are available with differential travel less than 0,0051 mm [0.0002 in].

Many center pivot irrigation systems utilize an end-gun (see Figure 2). This device is incorporated at the end of a span to catch the corners of a field that are not initially captured in the circular rotation of the pivot. A BZ switch is designed into the gun – controlling the rotational direction of the end gun.

Honeywell MICRO SWITCH BZ materials are more rugged, durable and long lasting due to the exceptional engineering manufactured into each switch. The diagram below showcases the many leading-edge features of the BZ Series basic switch that are commonly requested to address the challenging environment of center-pivot irrigation.

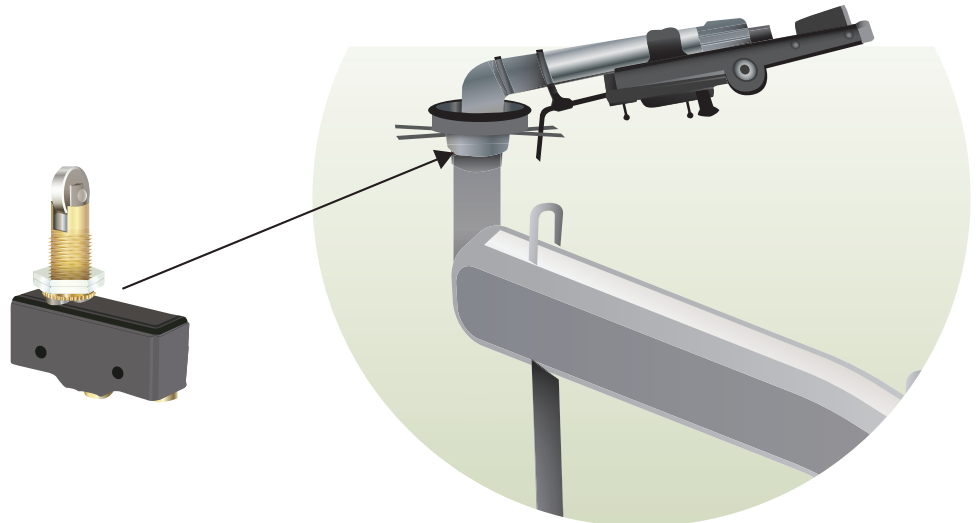
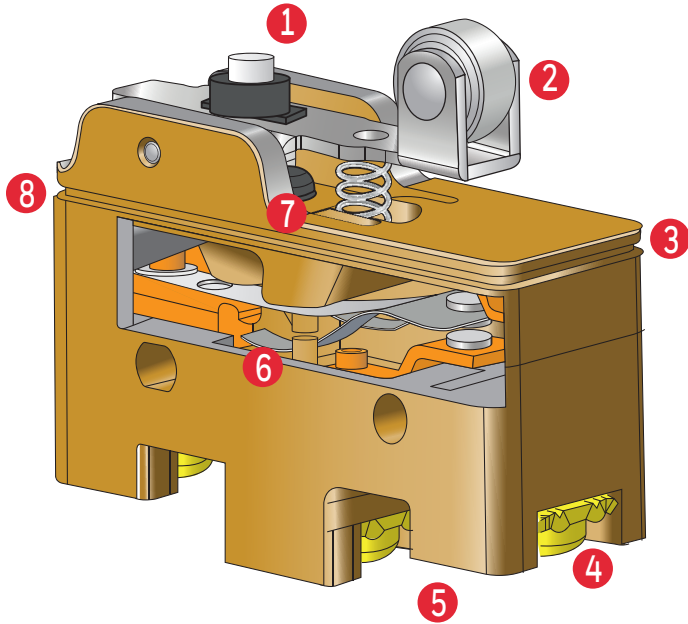

Figure 2. MICRO SWITCH BZ Switches in the End Gun

Figure 3. MICRO SWITCH BZ Switch Features



- 1 Originally developed by Micro Switch, this innovative lever design allows for the adjustment of the switch operating position characteristic to customize the operating point of each switch to accommodate the unique and changing requirements of each install
- 2 Robust stainless steel lever design employing sintered steel roller, integral bracket, and heavy duty return spring for long life and accurate repeatable characteristics
- 3 Switch case and cover components are made from a special formulated thermoset phenolic material to combat the negative impact of temperature and humidity to ensure dimensional stability and provide accurate/repeatable characteristics
- 4 Terminal screws employing Termini-Lox® lock-washers ensure all electrical connections remain secure while absorbing high levels of shock and vibration
- 5 Rugged switch case design stops electrical connections from rotating and prohibits the possibility of 'daisy-chaining' multiple switches together to over-ride safety requirements
- 6 Special alloy snap spring material provides extra long life and protects against the corrosive agriculture environments while allowing full agency coverage up to 15 A
- 7 Elastomer plunger seal provides splash and dust resistance while also providing excellent resistance to chemicals commonly found within agriculture and irrigation applications
- 8 Epoxy sealant applied to cover/case junction to provide splash and dust resistance

The MICRO SWITCH BZ basics are not the only feature contributing to the control of the pivot system day after day. Throughout the application, additional Honeywell switches are utilized for their durability, extended operating life, and accuracy.

Often incorporated on the end tower in the central housing, a [MICRO SWITCH HDLS heavy-duty limit switch](#) provides safety and crash detection. This allows the machine to stop at any tower within the irrigation system. The sensing arm is linked to the HDLS with a cable. If the arm senses an obstruction, it pulls the cable which actuates the switch. Once the switch is actuated, the control unit communicates a direction to either stop or reverse.

In addition, HDLS limit switches can be utilized to perform position stop for the entire system. For example, by utilizing the functionality of the HDLS switch, operators can custom set the pivot to run to a 130° range.

Our HDLS limit switches are rugged and dependable. They are available with a wide variety of housing materials, actuators, electrical characteristics, terminations, circuitry configurations and sealing ratings to fit an extensive range of applications.

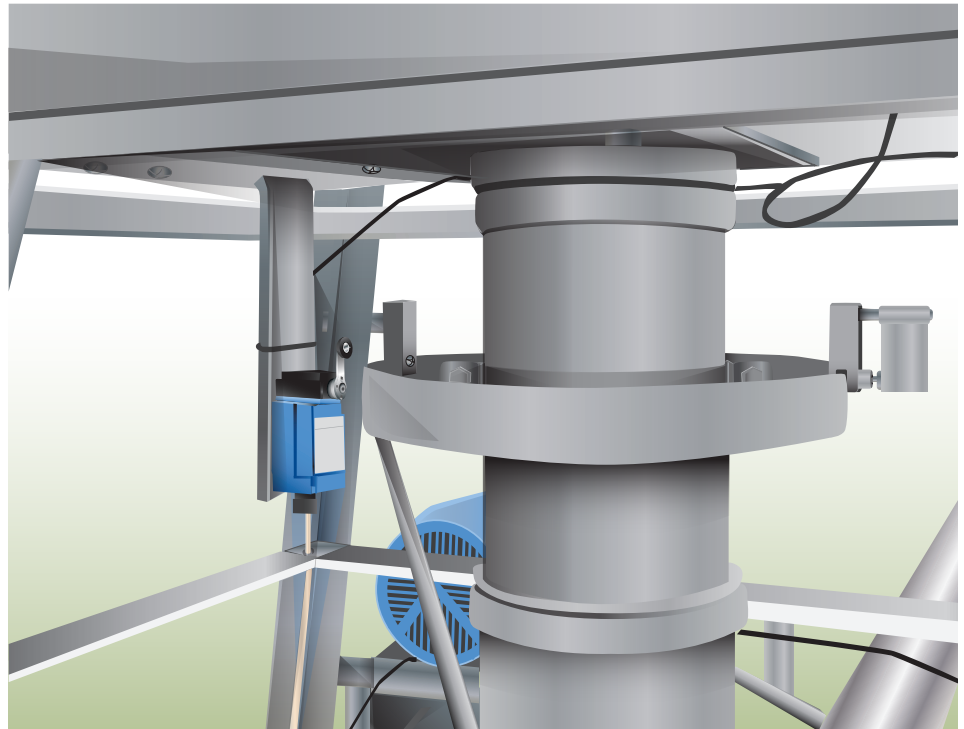
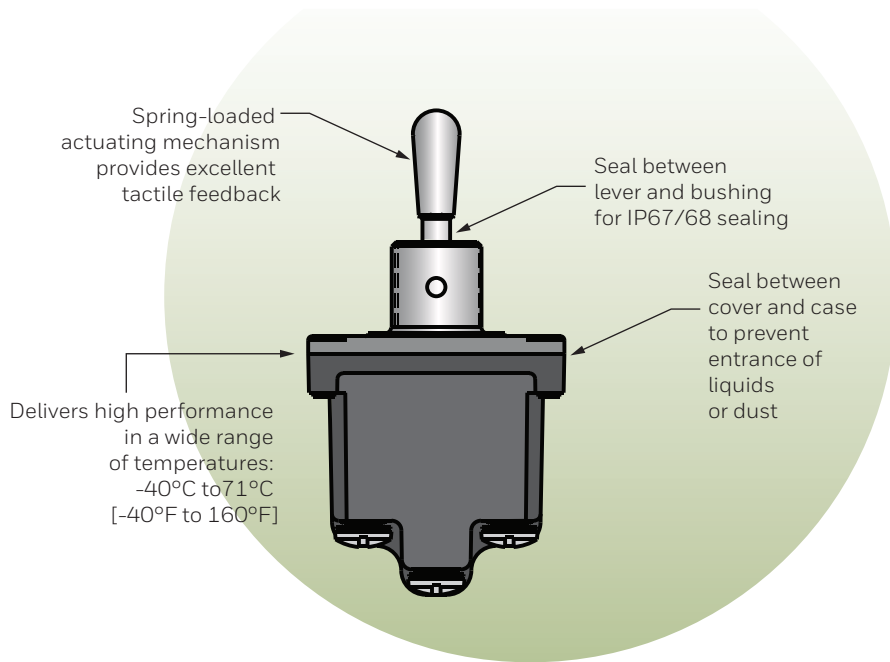

Figure 4. MICRO SWITCH HDLS LSA1A | Position Stop Application

Figure 5. MICRO SWITCH NT Toggle Switch Features



[Honeywell e-stop switches](#) may be located on the panel box to provide system shut off. The e-stop works in conjunction with the HDLS Series LSA1A on the pivot point that monitors the range and initiates the position stop.

Honeywell's push-pull/e-stop switches are robust, environmentally sealed, sliding contact switches incorporating two circuits with multiple combinations. The sliding contacts provide positive contact closure and opening when the switch knob is operated. They are designed and tested to withstand a wide range of environmental conditions and contaminants: severe temperatures, chemical splashes, pressure wash, vibration, dust, humidity and salt. The dual O-ring design protects the contact chamber by isolating it from moisture and/or any other contaminant. Our push-pull switches can be operated in humidity range of 5 %RH to 95 %RH and are designed for severe temperatures.

Lights are often incorporated into center pivot irrigation applications. Honeywell MICRO SWITCH toggle switches (most often the 1NT1-3 or 4NT1-3) are designed to turn lights off and on.

The [MICRO SWITCH NT Series](#)' quality construction includes a seal between the toggle lever and bushing, and between the cover and case. They are well suited for demanding outdoor environments, where they're subjected to vibration from equipment, temperature extremes, dust, splashing water, and/or hose-directed water.

True engineering excellence like ours delivers innovative, leading-edge switches that excel in challenging environments. Honeywell-patented technologies and custom application assistance deliver flexibility and value as we work with you to help identify the best solutions for your specific application needs.

With over a century of experience, our switches are unmatched when you need versatility, enhanced performance, productivity and increased safety in your applications. We invented the original MICRO SWITCH product and every year we manufacture millions of these industry-leading devices.

Honeywell expertise in switching has been legendary, with nearly a century of service, reliability, durability, and efficiency. We're ready to go for the next 100 years. Honeywell now manufactures over 120 million MICRO SWITCH products each year. Simple, superior, irreplaceable, the MICRO SWITCH product carries on. And on.

⚠️ WARNING MISUSE OF DOCUMENTATION

- The information presented in this application note is for reference only. Do not use this document as a product installation guide.
- Complete installation, operation, and maintenance information is provided in the instructions supplied with each product.

Failure to comply with these instructions could result in death or serious injury.

WARRANTY/REMEDY

Honeywell warrants goods of its manufacture as being free of defective materials and faulty workmanship during the applicable warranty period. Honeywell's standard product warranty applies unless agreed to otherwise by Honeywell in writing; please refer to your order acknowledgment or consult your local sales office for specific warranty details. If warranted goods are returned to Honeywell during the period of coverage, Honeywell will repair or replace, at its option, without charge those items that Honeywell, in its sole discretion, finds defective.

The foregoing is buyer's sole remedy and is in lieu of all other warranties, expressed or implied, including those of merchantability and fitness for a particular purpose. In no event shall Honeywell be liable for consequential, special, or indirect damages.

While Honeywell may provide application assistance personally, through our literature and the Honeywell web site, it is buyer's sole responsibility to determine the suitability of the product in the application.

Specifications may change without notice. The information we supply is believed to be accurate and reliable as of this writing. However, Honeywell assumes no responsibility for its use.

For more information

Honeywell Sensing & Safety Technologies services its customers through a worldwide network of sales offices and distributors. For application assistance, current specifications, pricing or the nearest Authorized Distributor, visit our [website](#) or call:

USA/Canada	+1 302 613 4491
Latin America	+1 305 805 8188
Europe	+44 1344 238258
Japan	+81 (0) 3-6730-7152
Singapore	+65 6355 2828
Greater China	+86 4006396841

Honeywell Sensing & Safety Technologies

830 East Arapaho Road
Richardson, TX 75081
www.honeywell.com